

FURUNO

Installation Manual
FISH SPECIES AND BIOMASS SOUNDER
Model FSS-3BB

(Product Name: FISH FINDER)

SAFETY INSTRUCTIONS i
SYSTEM CONFIGURATION iii
EQUIPMENT LISTS iv

1. MOUNTING **1-1**
1.1 Processor Unit 1-1
1.2 Transceiver Unit 1-3
1.3 Trackball Control Unit 1-4
1.4 Transducer 1-7
1.5 DVI/USB Repeater (Option) 1-9
1.6 Monitor Unit (Local Supply) 1-11

2. WIRING **2-1**
2.1 Processor Unit 2-2
2.2 Transceiver Unit 2-6
2.3 Trackball Control Unit 2-10
2.4 DVI/USB Repeater (Option) 2-12
2.5 Input/Output Sentences (NMEA0183) 2-14

3. INITIAL SETTINGS **3-1**
3.1 Initial Setting Menu 3-1
3.2 How to Set the Service Menu 3-5
3.3 Communication Port Setting 3-11
3.4 [Calibration] Menu 3-13
3.5 [Stabilization] Menu 3-15
3.6 How to Take a Still Image of the RX Monitor 3-18
3.7 Model Data for the IDENTI-FISH™ Graph 3-18
3.8 Reset to Default Setting 3-19

APPX. 1 JIS CABLE GUIDE **AP-1**

PACKING LIST(S) **A-1**
OUTLINE DRAWING(S) **D-1**
INTERCONNECTION DIAGRAM(S) **S-1**



FURUNO ELECTRIC CO., LTD.

www.furuno.com

All brand and product names are trademarks, registered trademarks or service marks of their respective holders.

ECF

(Elemental Chlorine Free)

The paper used in this manual
is elemental chlorine free.

FURUNO ELECTRIC CO., LTD.

9-52 Ashihara-cho,
Nishinomiya, 662-8580, JAPAN

• FURUNO Authorized Distributor/Dealer

All rights reserved. Printed in Japan

Pub. No. IME-23930-B1

(YOSH) FSS-3BB

A : APR. 2020

B1 : SEP. 21, 2021



0 0 0 1 9 7 1 4 4 1 1



SAFETY INSTRUCTIONS

The installer must read the safety instructions before attempting to install the equipment.



WARNING

Indicates a potentially hazardous situation which, if not avoided, could result in death or serious injury.



CAUTION

Indicates a potentially hazardous situation which, if not avoided, could result in minor or moderate injury.



Warning, Caution



Prohibitive Action



Mandatory Action



WARNING



ELECTRICAL SHOCK HAZARD
Do not open the equipment unless totally familiar with electrical circuits and service manual.

Only qualified personnel are allowed to work inside the equipment.



Turn off the power at the switchboard before beginning the installation.

Fire or electrical shock can result if the power is left on.



For wooden or FRP vessel using a steel tank, attach a zinc plate to the hull to prevent electrolytic corrosion.

Electrolytic corrosion can, in the worst case, result in loss of the transducer.



Install the transducer according to the installation instructions.

Failure to install the transducer correctly may result in water leakage and damage to the ship's hull.



Be sure no water leaks in at the transducer mounting location.

Water leakage can sink the vessel. Also, confirm that the transducer will not be loosened by ship's vibrations. The installer of the equipment is solely responsible for the proper installation of the equipment. FURUNO will assume no responsibility for any damage associated with improper installation.



CAUTION



Ground the equipment to prevent mutual interference.



Use the proper cable and fuse.

Use of an incorrect cable and fuse can damage the equipment and cause fire.



Do not transmit with the transducer out of water.

The transducer may become damaged.



Observe the following compass safe distance to prevent interference to a magnetic compass:

Unit	Standard compass	Steering compass
Processor Unit (FSS-301)	2.15 m	1.35 m
Transceiver Unit (FSS-302)	1.95 m	1.20 m
Trackball Control Unit (RCU-026)	0.30 m	0.30 m
DVI/USB Repeater (TM000-FDX06)	0.35 m	0.30 m

 **CAUTION**

 **Do not cover the transducer with FRP resin.**

The heat generated when the resin hardens may damage the transducer.

 **Do not install the transducer on the inner side of the hull.**

The signal strength is reduced and may affect the accuracy of measurements.

 **The transducer cable must be handled carefully, following the guidelines below.**

- Keep the cable away from oil and fuels.
- Keep the cable away from locations where it may be damaged during the installation.
- Do not paint the cable.
The cable sheath is made of chloroprene or vinyl chloride, which are easily damaged by plastic solvents such as toluene. Locate the cables away from plastic solvents.
- Do not shorten the transducer cable.
- Do not carry the transducer using only the cable.
The cable may become damaged or disconnected.

SYSTEM CONFIGURATION

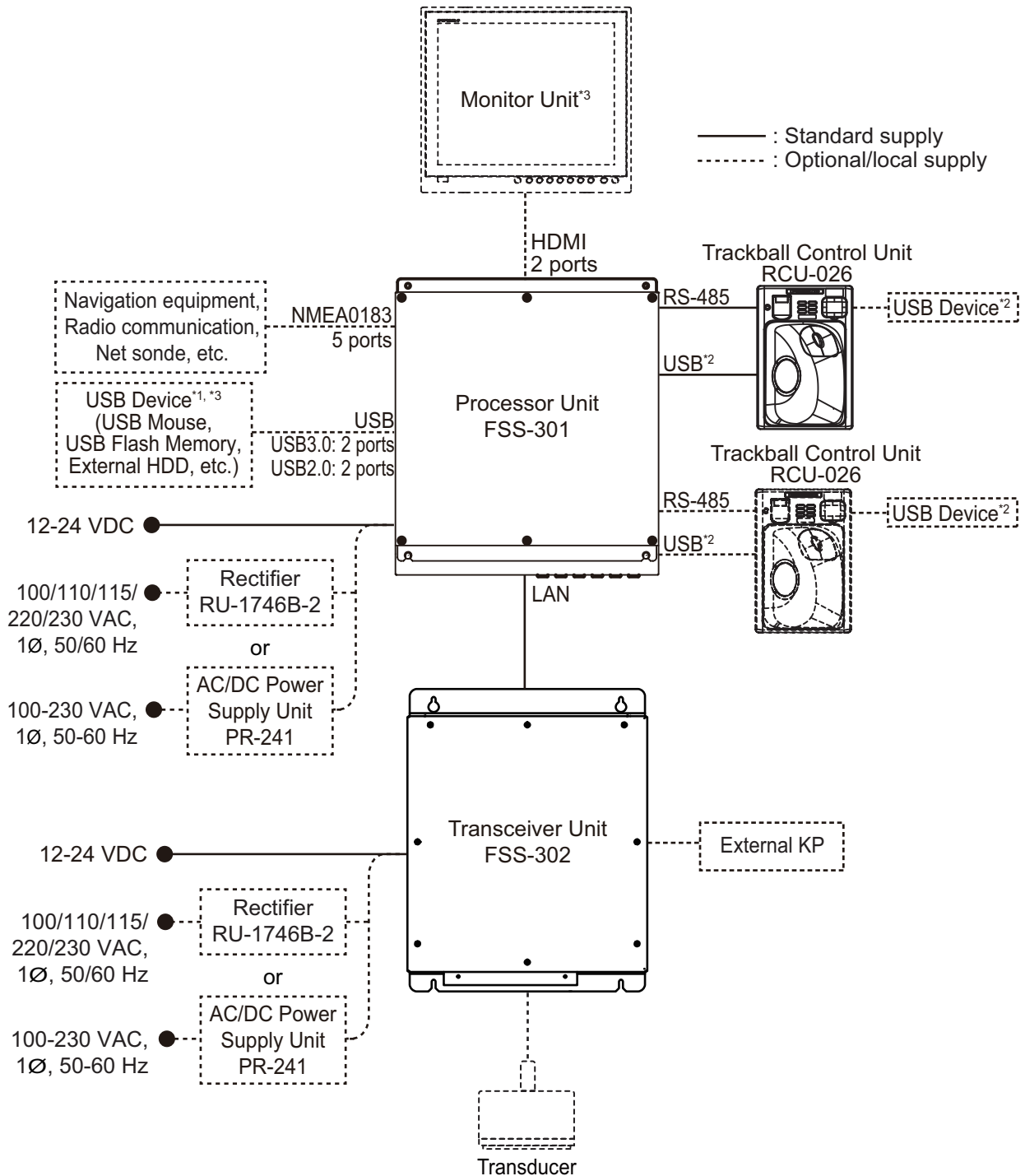

^{*1}: A maximum of four USB devices including RCU-026 can be connected to the processor unit.

^{*2}: To use the USB port on the RCU-026, connect the RCU-026 to the USB port on the processor unit, using the USB cable supplied with the RCU-026. If you do not use the USB port on the RCU-026, the USB connection between the RCU-026 and processor unit is not required.

^{*3}: To extend the distance between the processor unit and the monitor unit/USB device, use the optional DVI/USB repeater.

Note: The sub monitor cannot display the same screen as the main monitor.

EQUIPMENT LISTS

Standard Supply

Name	Type	Code No.	Qty	Remarks
Processor Unit	FSS-301	-	1	
Transceiver Unit	FSS-302	-	1	
Trackball Control Unit	RCU-026	-	1	
Installation Materials	CP10-09700	000-036-275	1	For processor unit
	CP02-09700	000-037-337	1	For transceiver unit
	CP24-02300	000-027-673	1	For trackball control unit
Accessories	FP24-00801	001-418-410	1	For trackball control unit
Spare Parts	SP26-00301	001-080-860	1	For processor unit
	SP02-05901	001-568-430	1	For transceiver unit

Option

Name	Type	Code No.	Remarks
Transducer	CM265LHG	-	For details about transducer specifications, see page 1-8.
	CM265LM	-	
	CM275LHW	-	
	CM599LHG	-	
	CM599LM	-	
	CM599LHW	-	
	PM111LHG	-	
	PM111LM	-	
	PM411LWM	-	
Trackball Control Unit	RCU-026	-	
Rectifier Unit	RU-1746B-2	-	
AC/DC Power Supply Unit	PR-241	-	
Ferrite Core	OP86-11	001-594-450	For PR-241
DVI/USB Repeater	TM000-FDX06_TXRX_30M	-	Transmitter and receiver units with LAN cable (30 m)
	TM000-FDX06_TXRX_50M	-	Transmitter and receiver units with LAN cable (50 m)
	TM000-FDX06_TXRX100M	-	Transmitter and receiver units with LAN cable (100 m)
	TM000-FDX06_TXRX	-	Transmitter and receiver units
	TM000-FDX06_RX	-	Transmitter unit
	TM000-FDX06_TX	-	Receiver unit
Flush Mount	OP24-27	001-171-820	For RCU-026

Name	Type	Code No.	Remarks	
Cable Assembly	HDMI-TO-DVI-L=5.3M	001-407-180	DVI-HDMI cable	5.3 m
	HDMI-TO-DVI-L=10.3M	001-407-170		10.3 m
	6TPSH-XH12X2-L5.0SP2	001-186-310-10	For RCU-026	5 m
	6TPSH-XH12X2-L10SP2	001-186-320-10		10 m
	MJ-A3SPF0024-035C	000-157-943-10	Power cable for DVI/USB repeater	3.5 m
	RNS-08-132	001-107-540-10	USB cable for the transmitter unit of the DVI/USB repeater	5 m
Cable Assembly	PARTS_WO2511	001-578-140	LAN cable for DVI/USB repeater	30 m
	PARTS_WO2512	001-578-150		50 m
	PARTS_WO2513	001-578-160		100 m
Extension Cable	C44-02 30M	001-374-620	For transducer	30 m
	C44-02 50M	001-374-580		50 m
Installation Materials	CP10-10100	000-036-244	LAN cable	10 m
	CP10-10110	000-036-245		15 m
	CP10-10120	000-036-246		30 m
	CP10-10130	000-036-247		40 m
	CP10-10140	000-036-248		50 m
	CP10-10150	000-036-722		100 m

This page is intentionally left blank.

1. MOUNTING

NOTICE

Do not apply paint, anti-corrosive sealant or contact spray to coating or plastic parts of the equipment.

Those items contain organic solvents that can damage coating and plastic parts, especially plastic connectors.

1.1 Processor Unit

The processor unit can be installed on a deck or bulkhead.

Mounting considerations

Select a mounting location, keeping in mind the following points:

- Locate the unit out of direct sunlight and away from heat sources.
- Locate the unit away from places subject to water splash and rain.
- Select a mounting location considering the length of the cables to be connected to the unit.
- Select a location where shock and vibration are minimal.
- Be sure the mounting location is strong enough to support the weight of the unit.
- Referring to the outline drawings at the back of this manual, allow sufficient space for maintenance and service.
- A magnetic compass will be affected if the unit is placed too close to the magnetic compass. Observe the compass safe distances at the front of this manual to prevent interference to a magnetic compass.
- For bulkhead installations, secure the unit so that the cable entrance faces downward.

1. MOUNTING

1.1.1 Deck mount

1. Drill four pilot holes in the mounting location for mounting bolts, referring to the outline drawing at the back of this manual.
2. Secure the unit using the four hex head slot bolts (M6×20, supplied).

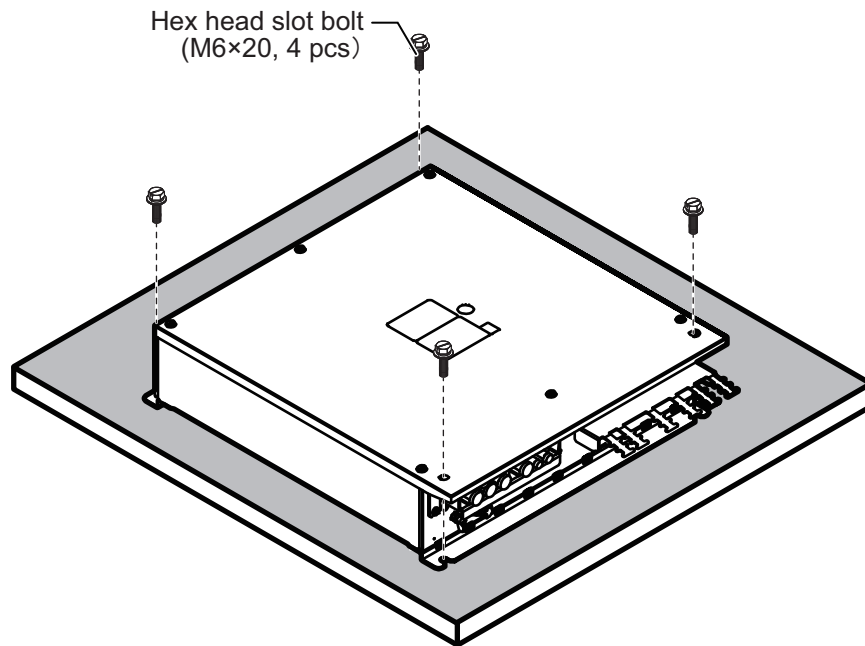

1.1.2 Bulkhead mount

1. Drill four pilot holes in the mounting location for mounting bolts (M6×20, supplied), referring to the outline drawing at the back of this manual.
2. Screw the two hex head slot bolts into the lower pilot holes. Leave 5 mm of thread visible.
3. Set the notches of the unit onto the bolts fastened at step 2.
4. Screw the two hex head slot bolts into the upper fixing holes.
5. Fasten all bolts tightly to secure the unit in place.

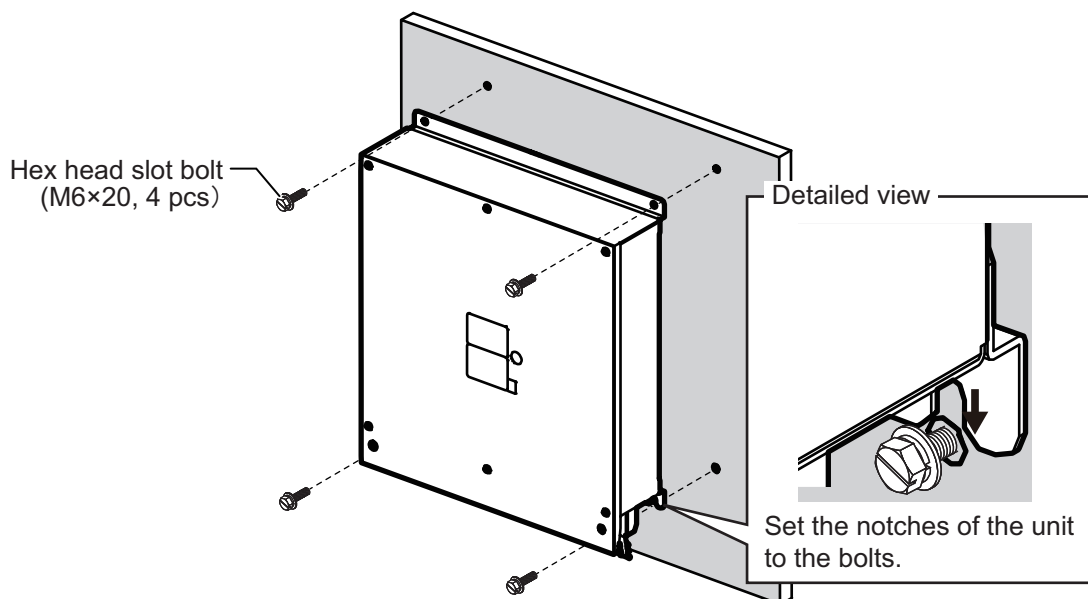

1.2 Transceiver Unit

The transceiver unit can be installed on a deck or bulkhead.

Mounting considerations

Select a mounting location, keeping in mind the following points:

- Locate the unit out of direct sunlight and away from heat sources.
- Select an installation location that is well ventilated.
- Locate the unit away from places subject to water splash and rain.
- Select a mounting location considering the length of the cables to be connected to the unit.
- Select a location where shock and vibration are minimal.
- Be sure the mounting location is strong enough to support the weight of the unit.
- Referring to the outline drawings at the back of this manual, allow sufficient space for maintenance and service.
- A magnetic compass will be affected if the unit is placed too close to the magnetic compass. Observe the compass safe distances at the front of this manual to prevent interference to a magnetic compass.
- For the bulkhead installations, secure the unit so that the cable entrance faces downward.

1.2.1 Deck mount

1. Drill four pilot holes in the mounting location for self-tapping screws ($\phi 5 \times 20$, supplied), referring to the outline drawing at the back of this manual.
2. Secure the unit using the four self-tapping screws.

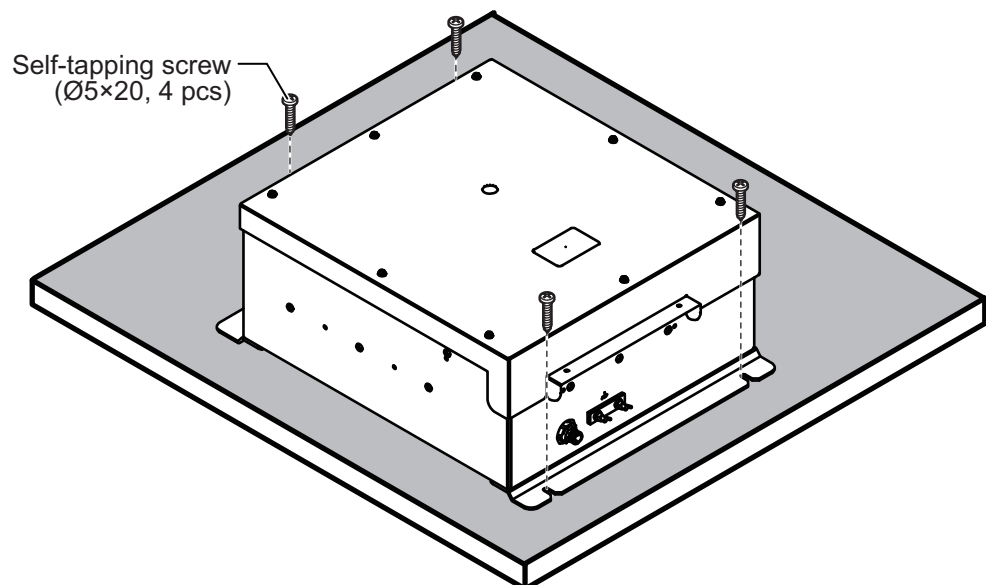

1. MOUNTING

1.2.2 Bulkhead mount

1. Drill four pilot holes in the mounting location for self-tapping screws ($\phi 5 \times 20$, supplied), referring to the outline drawing at the back of this manual.
2. Screw two self-tapping screws into the upper pilot holes. Leave 5 mm of thread visible.
3. Hang the unit onto the screws fastened at step 2.
4. Screw two self-tapping screws into the lower fixing holes.
5. Fasten all screws tightly to secure the unit in place.

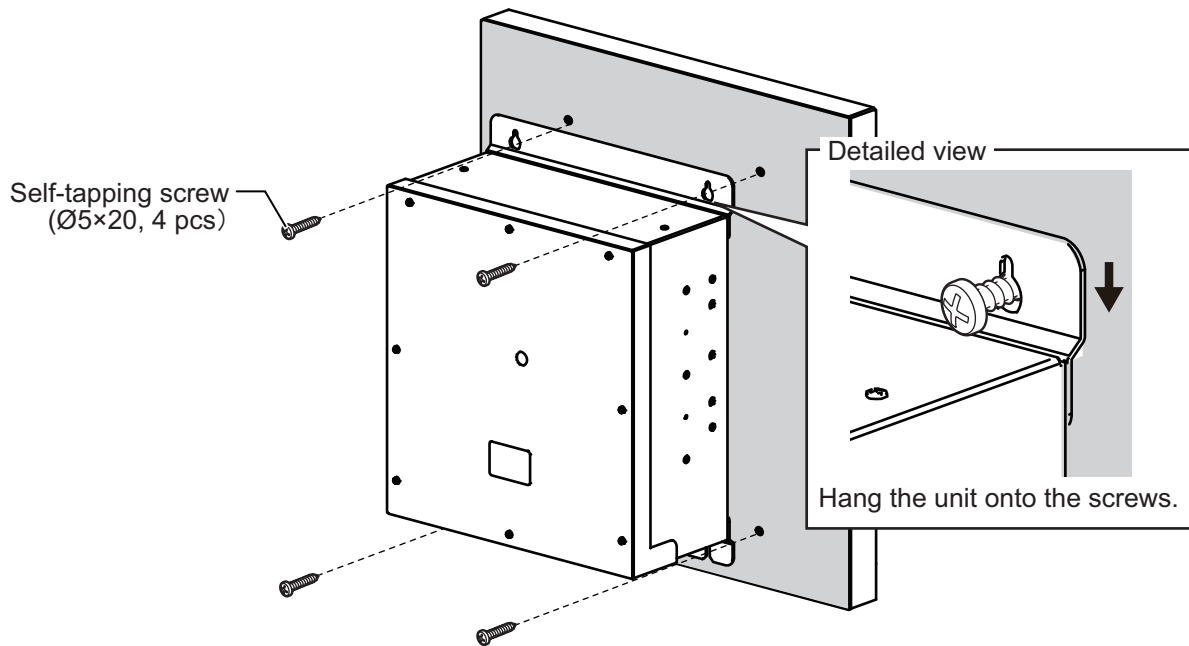

1.3 Trackball Control Unit

The trackball control unit can be installed on a desktop or flush mounted in a console. For the desktop installation, the unit can be laid flat or tilted.

Mounting considerations

- Select a location where the trackball control unit can be operated easily.
- Locate the unit away from heat sources.
- Locate the unit away from places subject to water splash and rain.
- Referring to the outline drawings at the back of this manual, allow sufficient space for maintenance and service.
- Select a mounting location considering the length of the cables to be connected to the unit.
- Select a location where shock and vibration are minimal.
- A magnetic compass will be affected if the unit is placed too close to the magnetic compass. Observe the compass safe distances at the front of this manual to prevent interference to a magnetic compass.

1.3.1 Desktop mount

You can install the unit flat on the desktop, or use the fixing plate for a tilted installation.

How to mount the unit tilted

Use the supplied desktop fixing plate to mount the unit tilted.

1. Attach the desktop fixing plate to the trackball control unit, using the two washer head screws (M3×8, supplied).

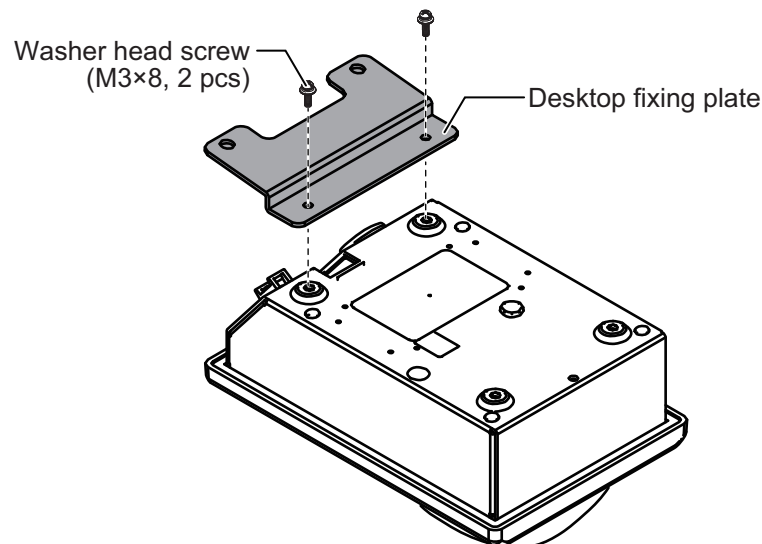

2. Secure the unit using the two self-tapping screws (Ø5×20, supplied).

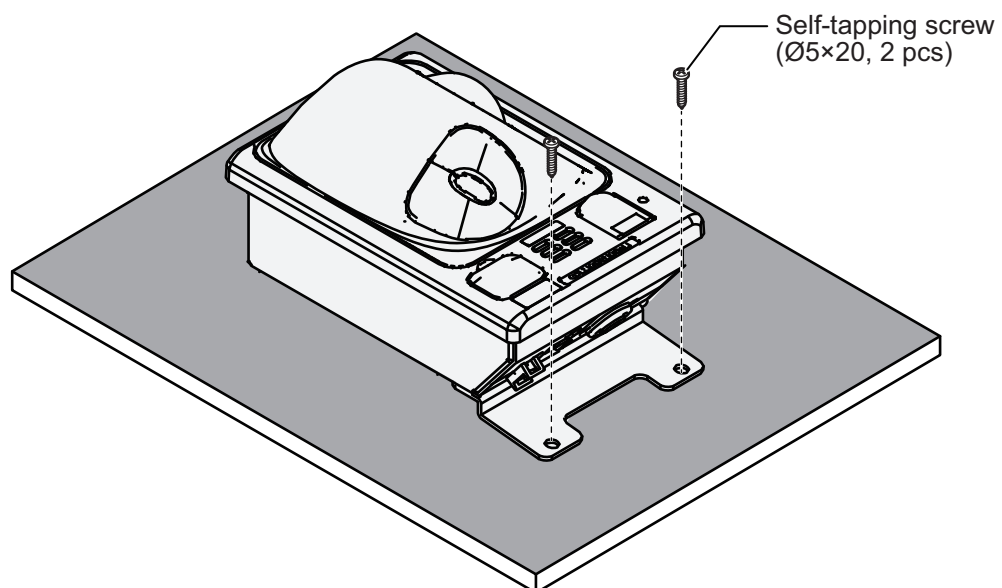

How to install the unit flat on the desktop

Secure the trackball control unit without the desktop fixing plate to install the unit flat on the desktop.

1. Drill four mounting holes of 4 mm diameter referring to the outline drawing at the back of this manual.

1. MOUNTING

- Secure the unit with the four washer head screws (M3×12, supplied) from the underside of the desktop.

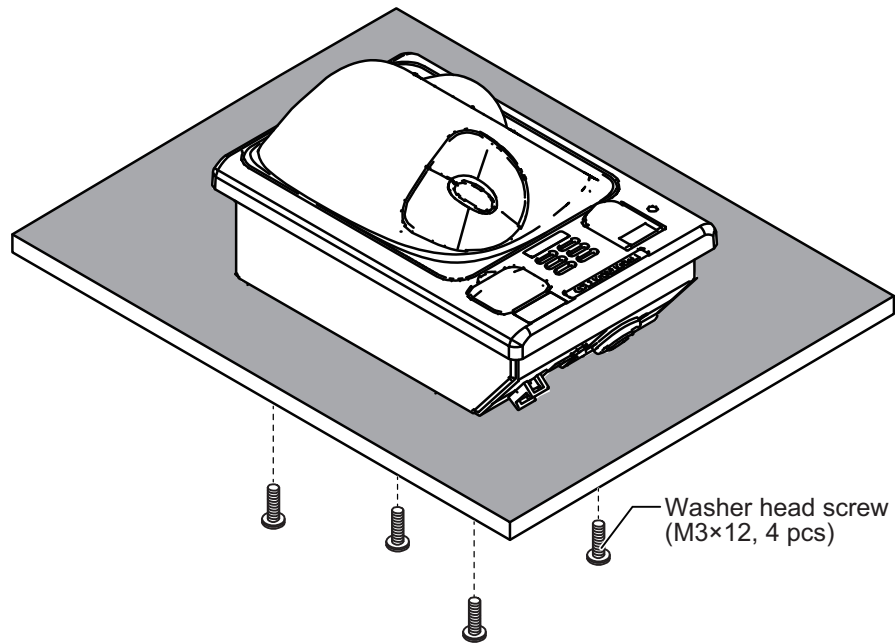

1.3.2 Flush mount

Note: For flush mounting in a panel, the mounting surface must be flat. Do not install the unit on an uneven surface.

Prepare the optional flush mount kit (OP24-27) for flush mounting the trackball control unit.

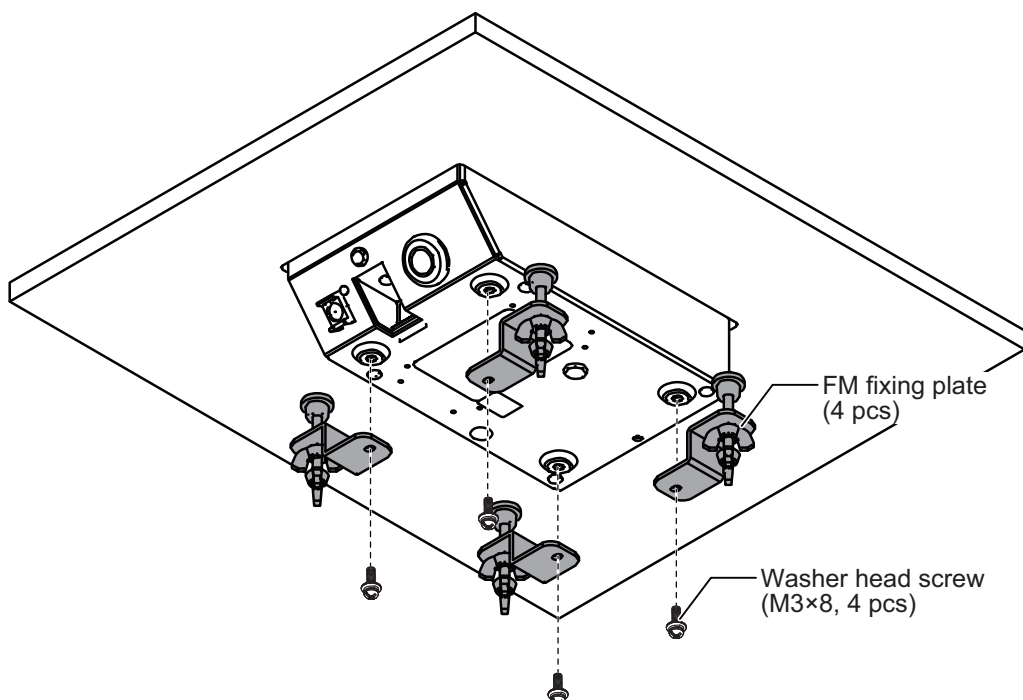

- Make a mounting hole in the mounting location, referring to the outline drawing at the back of this manual.
- Set the unit to the mounting hole.
- Attach the four FM fixing plates to the unit from the rear side, using the washer head screws (M3×8).

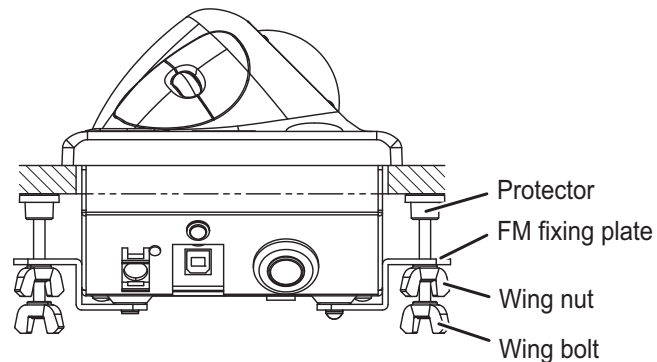

4. Fasten each wing bolt until the protector for the screw is firm against the mounting panel.
5. Fasten each wing nut tightly to secure the unit.



1.4 Transducer

 CAUTION	
	<ul style="list-style-type: none"> • Do not cover the transducer with FRP resin. The heat generated when the resin hardens may damage the transducer. • Do not install the transducer on the inner side of the hull. The signal strength is reduced and may affect the accuracy of measurements.

The performance of the fish finder depends on the transducer position. When selecting a mounting location, keep in mind following points.

- A place least affected by air bubbles should be selected since turbulence blocks the sounding path.
- Select a place least influenced by engine noise.
- Install the transducer face parallel to the sea surface.

It is known that air bubbles are fewest at the place where the bow first falls and the next wave raises, at usual cruising speed. In small, slow-speed boats, the position between 1/2 and 2/3 of the ship's length from the bow is usually a good place.

1. MOUNTING

Specifications for optional Airmar transducer

Transducer	Output	Frequency	Cable length	Hull Material	Thru-hull pipe	Tank
CM265LHG* ¹	1 kW/ 1 kW	42 to 65 kHz/ 130 to 210 kHz	12 m	Steel	TFB-7000 (1)	T-711
				FRP	-	T-711F
CM265LM	1 kW/ 1 kW	42 to 65 kHz/ 85 to 135 kHz	12 m	Steel	TFB-7000 (1)	T-711
				FRP	-	T-711F
CM275LHW	1 kW/ 1 kW	42 to 65 kHz/ 150 to 250 kHz	12 m	Steel	TFB-7000 (1)	T-711
				FRP	-	T-711F
CM599LHG* ¹	3 kW/ 2 kW	28 to 60 kHz/ 130 to 210 kHz	15 m	Steel	TFB-7000 (1)	T-712
				FRP	TRB-1100 (1)	T-712F
CM599LM	3 kW/ 2 kW	28 to 60 kHz/ 80 to 130 kHz	15 m	Steel	TFB-7000 (1)	T-712
				FRP	TRB-1100 (1)	T-712F
CM599LHW	3 kW/ 1 kW	28 to 60 kHz/ 130 to 210 kHz	15 m	Steel	TFB-7000 (1)	T-712
				FRP	TRB-1100 (1)	T-712F
PM111LHG* ²	2 kW/ 2 kW	38 to 75 kHz/ 130 to 210 kHz	15 m	Steel	TFB-7000 (1)	T-712
				FRP	TRB-1100 (1)	T-712F
PM111LM	2 kW/ 2 kW	38 to 75 kHz/ 80 to 130 kHz	15 m	Steel	TFB-7000 (1)	T-712
				FRP	TRB-1100 (1)	T-712F
PM411LWM	2 kW/ 2 kW	40 to 60 kHz/ 80 to 130 kHz	15 m	Steel	TFB-7000 (1)	T-712
				FRP	TRB-1100 (1)	T-712F

*1: Fish size histogram and IDENTI-FISH™ feature compatible.

*2: Fish size histogram compatible.

Note 1: For how to install the Airmar transducer, see the installation instructions supplied with the transducer. If the transducer is not installed correctly, the transducer may be damaged due to overheating.

Note 2: Do not remove the warranty label that is attached on the transducer cable. If removed, the transducer may not be covered by Airmar product warranty.

Note 3: Do not cut the transducer cable.

1.5 DVI/USB Repeater (Option)

To extend the distance between the display unit and the processor unit/USB device, use the optional DVI/USB repeater. Cable extension without the repeater can result in signal loss and incorrect data display.

The DVI/USB repeater has two units, one transmitter unit and one receiver unit. The following figure shows the general connection for the DVI/USB repeater.

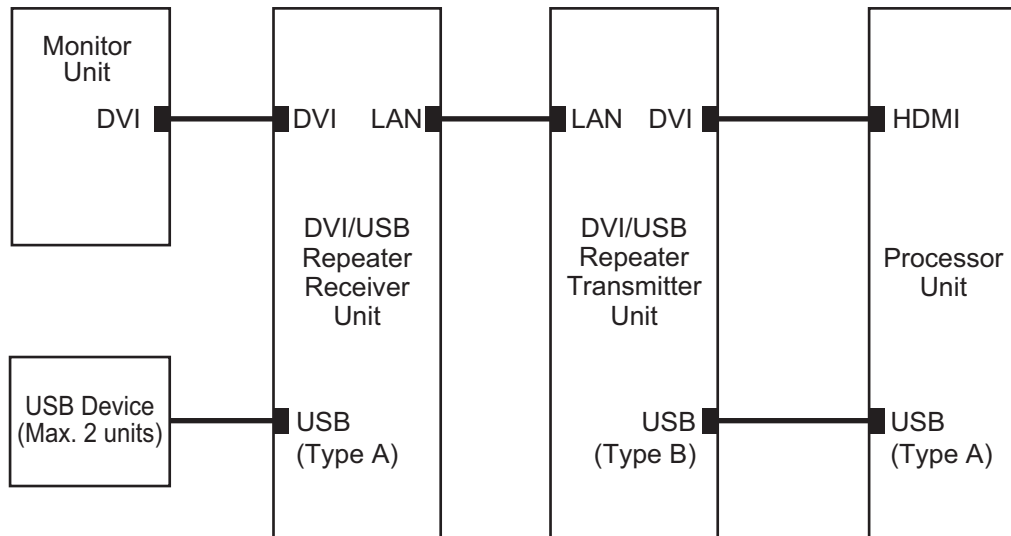

The DVI/USB repeater can be installed on a deck or bulkhead. Cable connection is slightly different between transmitter and receiver unit. For this reason, it is important that you identify each unit before mounting. The following table and figure show how to identify the units.

Unit	What to look for
Receiver Unit	Female SRCN connector, USB type A connector × 2
Transmitter Unit	Male SRCN connector, USB type B connector

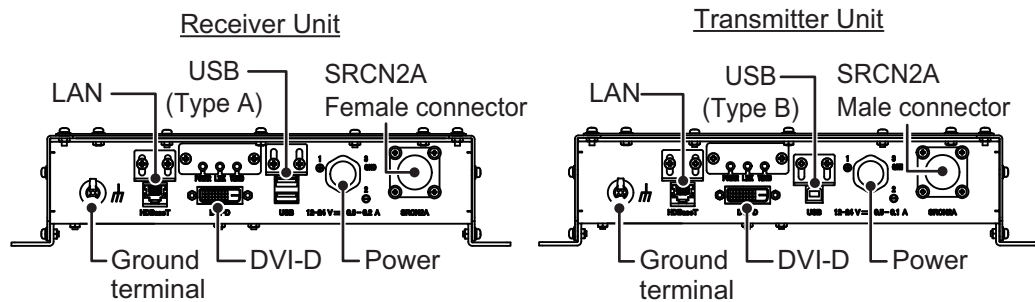

1. MOUNTING

Mounting considerations

- Locate the unit away from heat sources.
- Locate the unit away from places subject to water splash and rain.
- Select a mounting location considering the length of the cables to be connected to the unit.
- Select a location where shock and vibration are minimal.
- Referring to the outline drawings at the back of this manual, allow sufficient space for maintenance and service.
- A magnetic compass will be affected if the unit is placed too close to the magnetic compass. Observe the compass safe distances at the front of this manual to prevent interference to a magnetic compass.
- For bulkhead installations, secure the unit so that the cable entrance faces downward.
- The maximum cable length for the video signal cable is as follows:
 - HDMI-TO-DVI-L cable between processor unit and transmitter unit: 5.3 m
 - DVI-D/D S-LINK cable between receiver unit to monitor unit: 5 m

Mounting procedure

1. Drill four pilot holes in the mounting location for mounting screws ($\phi 5 \times 20$, local supply), referring to the outline drawing at the back of this manual.
2. Screw the four self-tapping screws into the pilot holes. Leave 5 mm of thread visible.
3. Hang the unit onto the screws fastened at step 2.
4. Fasten all screws tightly to secure the unit in place.

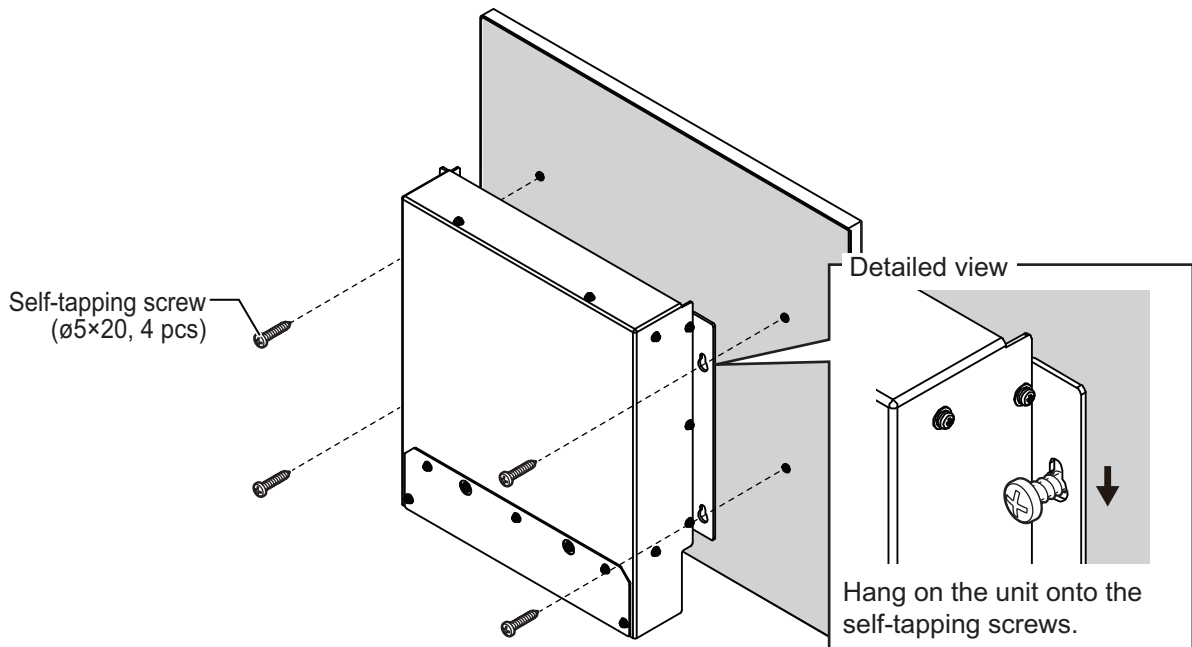

1.6 Monitor Unit (Local Supply)

You can connect a FURUNO MU series monitor or a commercial monitor as a monitor unit. The monitor unit must have the following specifications.

- Video signal: HDMI (type A) or DVI-D* (Single link)
*: The optional HDMI-TO-DVI-L cable is required for DVI-D.
- Resolution: XGA (1024 x 768), SXGA (1280 x 1024), Full-HD (1920 x 1080), UXGA (1600 x 1200) or WUXGA (1920 x 1200) are available.

For how to install the monitor unit, see the installation instructions of the monitor.

1. MOUNTING

This page is intentionally left blank.

2. WIRING

The following figure shows the general connections for the FSS-3BB. For detailed information, see the interconnection diagram. Many of the cables mentioned are JIS (Japan Industrial Standards) cables. If not available locally, use the equivalent. See the cable guide in the Appendix for how to select equivalent cables.

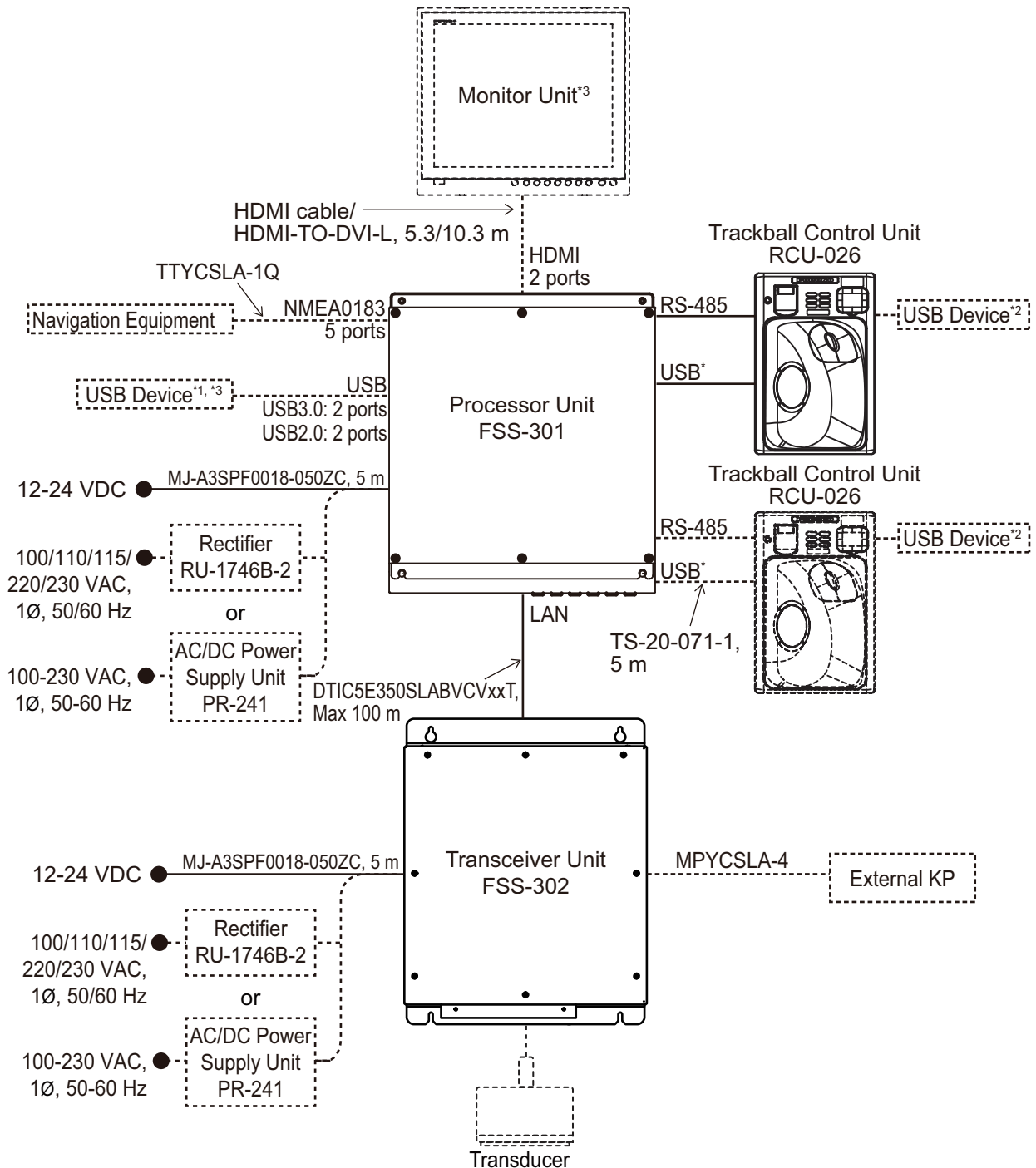

¹: A maximum of four USB devices including RCU-026 can be connected to the processor unit.

²: To use the USB port on the RCU-026, connect the RCU-026 to the USB port on the processor unit, using the USB cable supplied with the RCU-026. If you do not use the USB port on the RCU-026, the USB connection between the RCU-026 and processor unit is not required.

³: To extend the distance between the processor unit and the monitor unit/USB device, use the optional DVI/USB repeater.

2.1 Processor Unit

2.1.1 Connectors

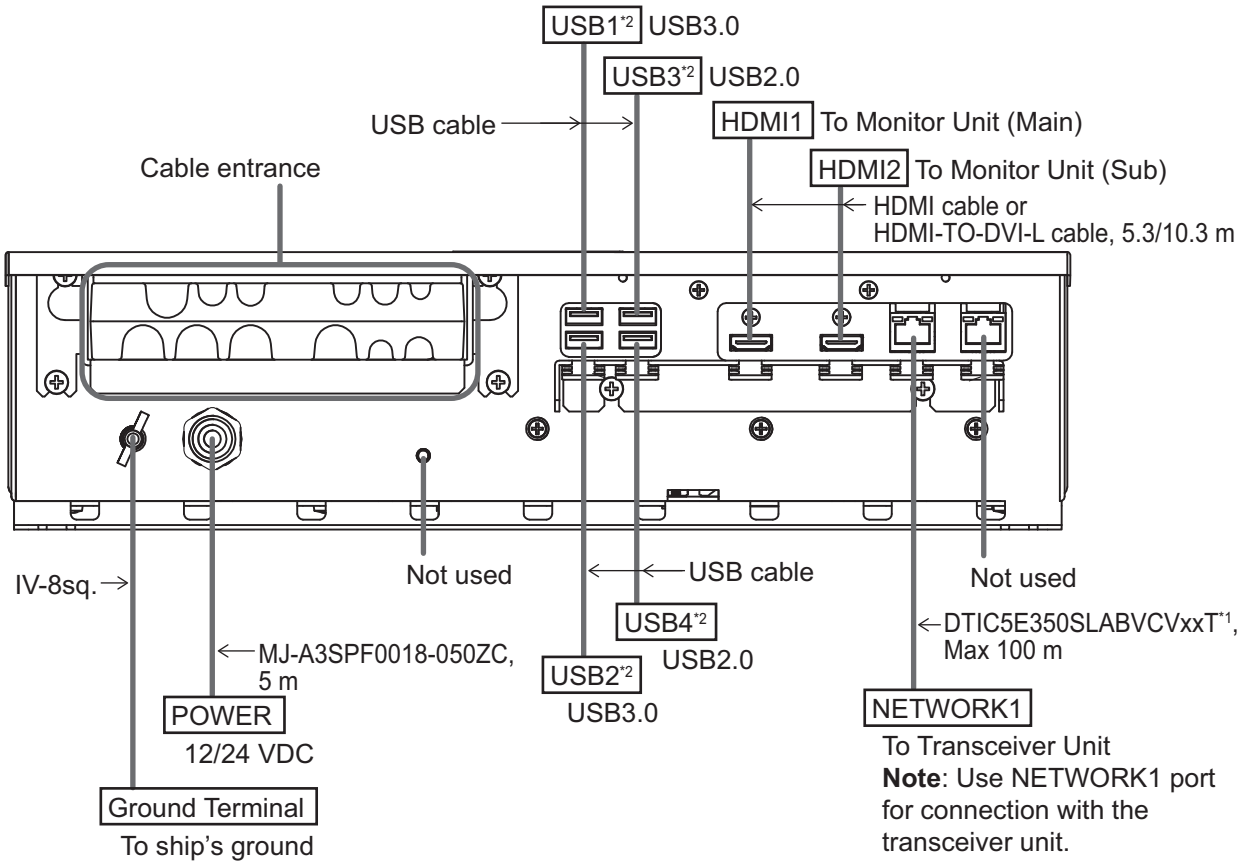

*1: Fabricate the cable referring to section 2.1.3.

*2: To connect a USB device, use the lower USB port first.

Secure the USB, HDMI and LAN cables to the cable clamp with a cable tie (local supply). For the USB cables, use two cable ties for each cable.

Note 1: The cable clamp can be adjusted to allow larger connectors, such as USB or HDMI, to be connected.

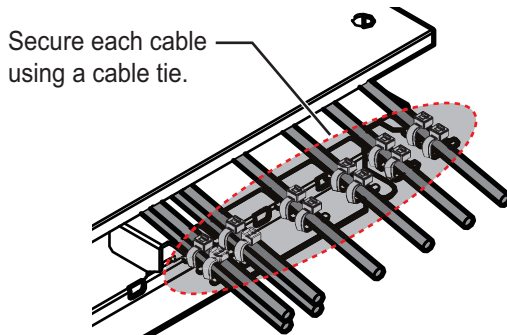

Unfasten the indicated screws to adjust the cable clamp. Refasten the screws to secure the cable clamp after adjustment.

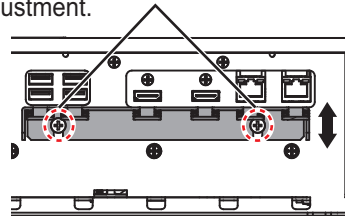

Note 2: The maximum cable length for USB2.0 and USB3.0 is as follows. To extend the USB cable, the optional DVI/USB repeater is required. If you extend the USB cable without the DVI/USB repeater, the USB device operation is not guaranteed.

• USB2.0: Max. 5 m

• USB3.0: Max. 3 m

2.1.2 Internal wiring and cable clamp position

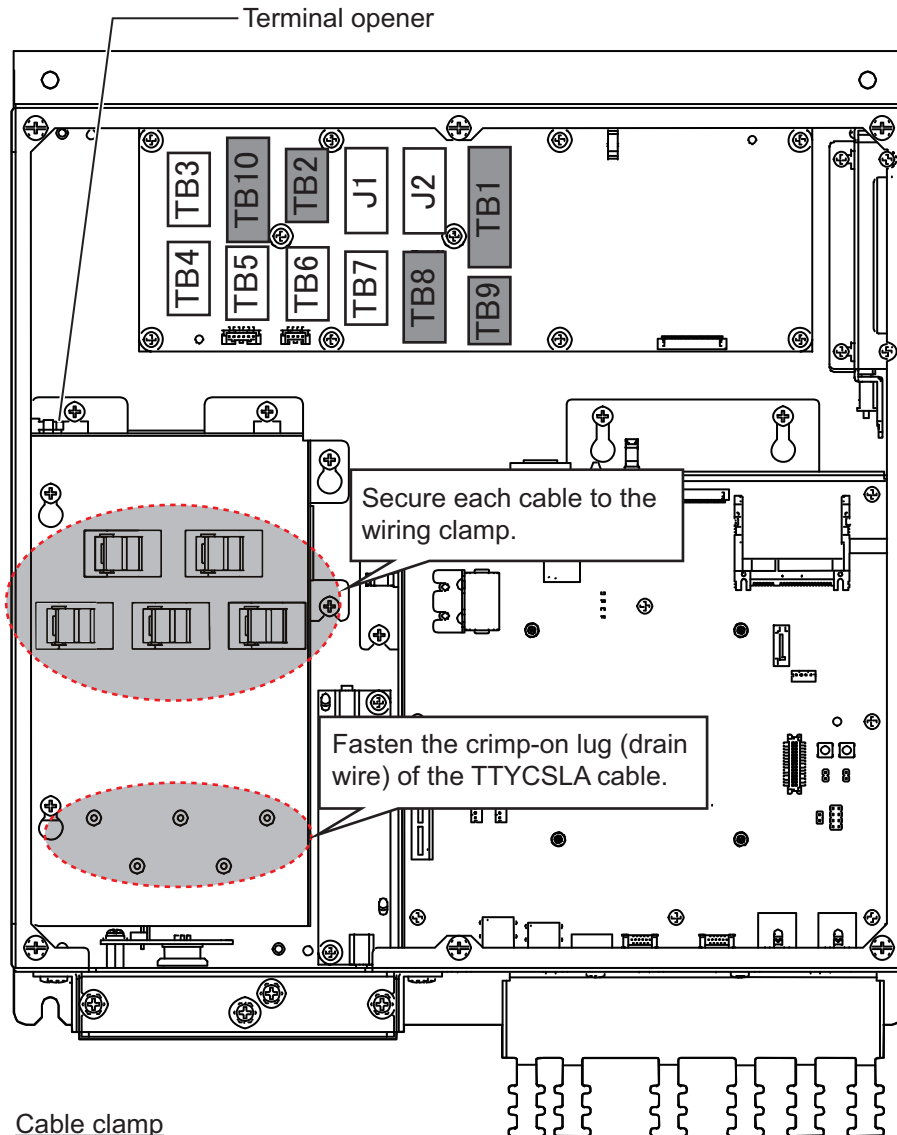

Cable clamp

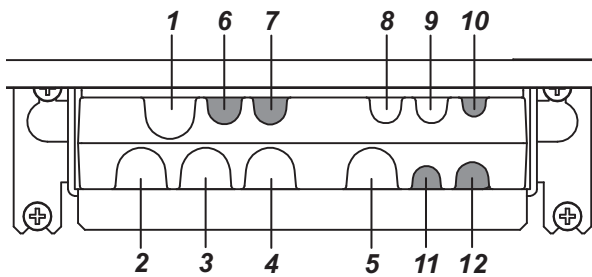

Clamp position	Connect to	Cable from	Cable
1 to 5	TB3 to TB7	NMEA0183 equipment	TTYCSLA-1Q*
6 to 7	-	Not used	
8	J1	Trackball control unit	-
9	J2	Trackball control unit	-
10 to 12	-	Not used	

*: Fabricate the cables referring to section 2.1.3.

2.1.3 Cable fabrication

LAN cable

Fabricate the LAN cable (DTIC5E350SLABVCVxxT, max 100 m), referring to the following figure. After fabricating the cable, attach the modular connector.

Note: This equipment only uses straight cables. Use a CAT5E LAN cable.

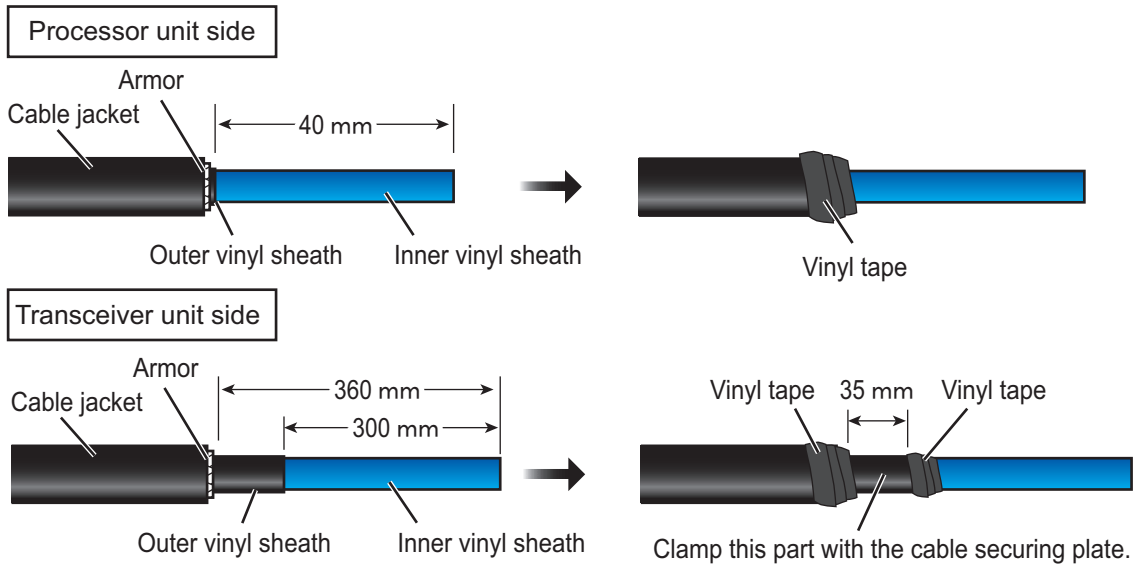

1 Expose inner vinyl sheath.

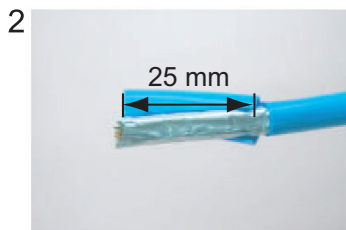

2 Remove the inner vinyl sheath by approx. 25 mm. Be careful not to damage inner shield and cores.

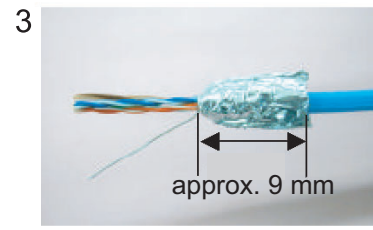

3 Fold back the shield, wrap it onto the inner vinyl sheath and cut it, leaving approx. 9 mm.

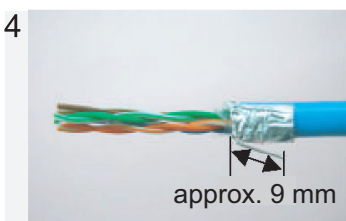

4 Fold back drain wire and cut it, leaving approx. 9 mm.

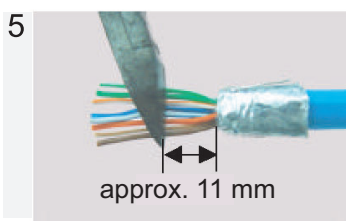

5 Straighten and flatten the cores in colored order and cut them, leaving approx. 11 mm.

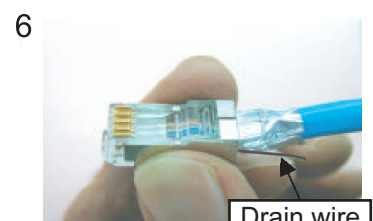

6 Insert the cable into the modular plug so that the folded part of the shield enters into the plug housing. The drain wire should be located on the tab side of the jack.



7 Using special crimping tool MPT5-8AS (PANDUIT CORP.), crimp the modular plug. Finally, check the plug visually.

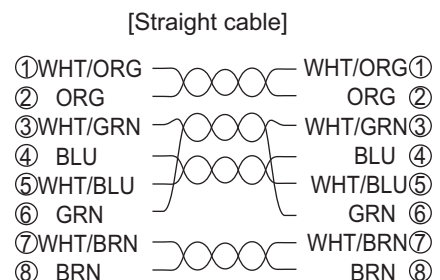
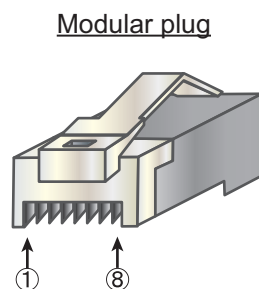

TTYCSLA-1Q cable (NMEA0183 connection)

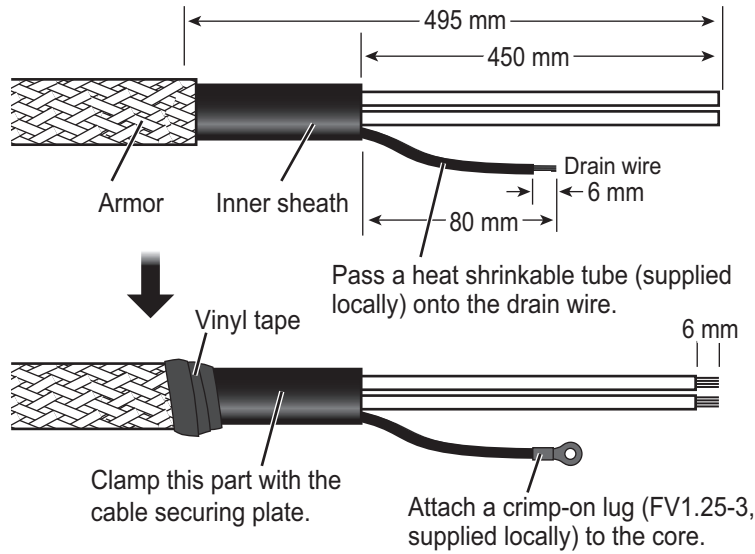

How to connect wires to a terminal block connector

Press downward.
Terminal opener
Terminal block connector
Twist

Procedure

1. Twist the cores.
2. Press the terminal opener downward.
3. Insert the wire in the hole.
4. Remove the terminal opener.
5. Pull the wire to confirm that it is secure.

2.1.4 How to change the fuse

Change the fuse in the fuse holder on the power cable according to the input voltage, referring to the following table. Fuses are supplied as spare parts.

Note: For the power cable of the transceiver unit, it is not required to change the fuse.

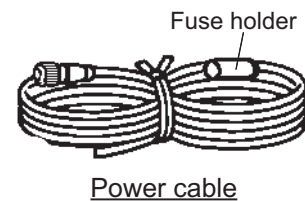

⚠ WARNING

⚠ Use the proper fuse.

Fuse rating is shown in the table below.
Use of a wrong fuse can result in damage to the equipment.

Input voltage	Rating of fuse
12 VDC	15 A (factory default)
24 VDC	7 A

2.2 Transceiver Unit

2.2.1 Internal wiring and cable clamp position

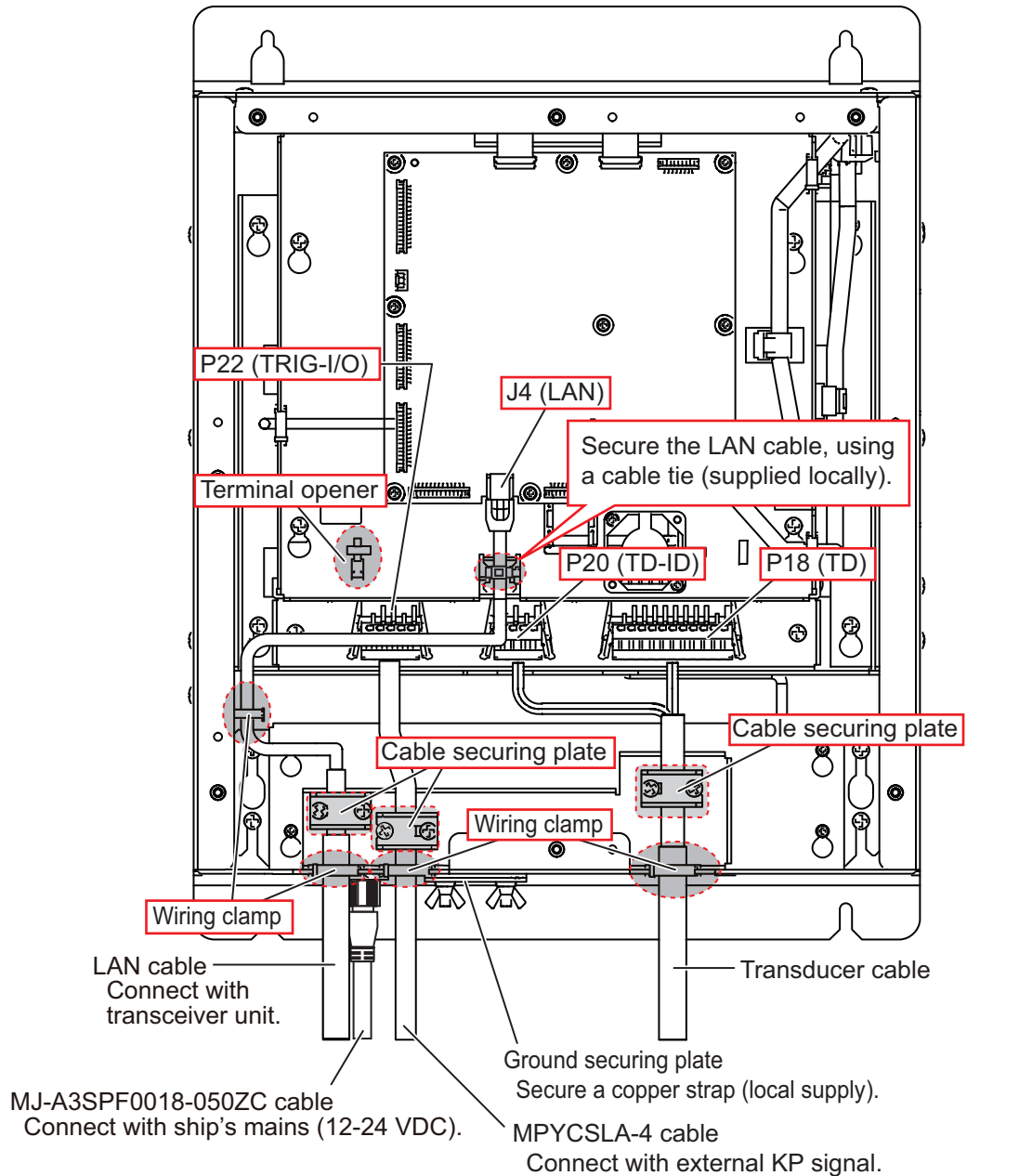

Power supply

Connect the supplied power cable (MJ-A3SPF0018-050ZC, 5 m) to ship's mains (12-24 VDC).

Note: The transceiver unit does not have a power switch. Therefore, the power cable must be connected to the ship's mains through the switchboard. If you do not use this equipment for a while, turn the breaker off to cut off the power to the transceiver unit. Also, you must turn the power off or disconnect the power cable for maintenance.

Grounding

This unit must be grounded to prevent mutual interference. Connect a copper strap (local supply) between the transceiver unit and the ship’s ground. The length of the copper strap should be as short as possible.

External equipment connection

Note: Fabricate the cables referring to section 2.2.2.

The LAN cable, external KP cable and transducer cable should be passed through the wiring clamp and secured with the cable securing plate. For the transducer cable, the shield must be clamped with the plate.

Lay the transducer cable well away from other cables to prevent interference. If the transducer cable is laid along with a equipment or cable that emits high-frequency noise, the transducer cable may interfered and the fish finder cannot display echoes correctly.

2.2.2 Cable fabrication

LAN cable

Fabricate the cable referring to section 2.1.3.

MPYCSLA-4 cable (external KP connection)

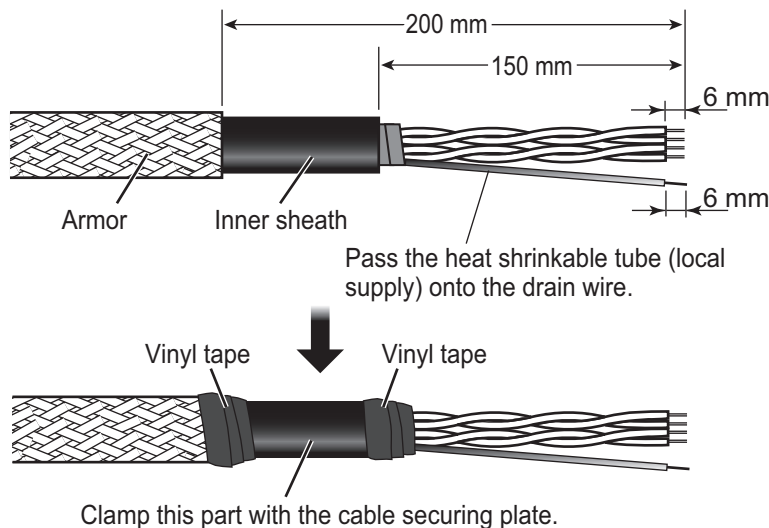

How to connect wires to a terminal block connector

Press downward.
Terminal opener
Terminal block connector
Twist

Procedure

1. Twist the cores.
2. Press the terminal opener downward.
3. Insert the wire in the hole.
4. Remove the terminal opener.
5. Pull the wire to confirm that it is secure.

2. WIRING

Transducer cable

1. Remove the vinyl sheath by approx. 150 mm to expose the braided shield.

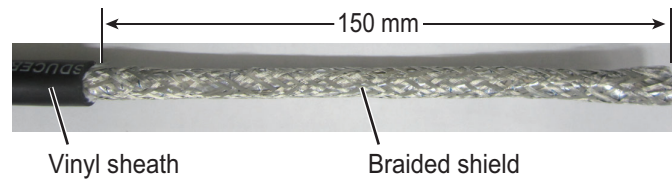

2. Pull the cores out from the braided shield, remove the aluminum tape and cut the purple signal core.

Note: Be careful not to cut the four drain wires.

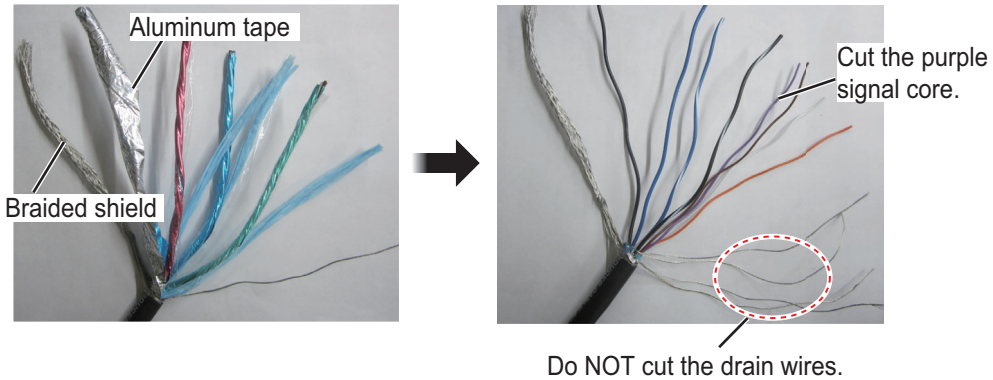

3. Wind the braided shield and drain wires around the vinyl sheath, then wind vinyl tape around edge of the shield.

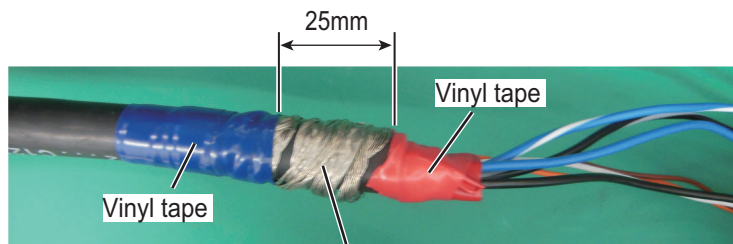

Wind the braided shield and drain wires.
Clamp this part with the cable securing plate.

4. Remove the sheath by approx. 6 mm, then attach the terminal block connector.

How to connect wires to a terminal block connector

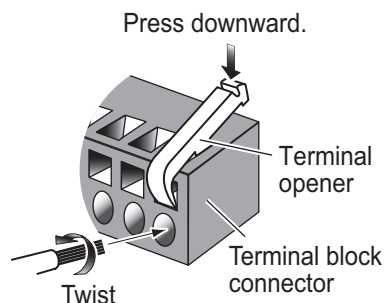

Procedure

1. Twist the cores.
2. Press the terminal opener downward.
3. Insert the wire in the hole.
4. Remove the terminal opener.
5. Pull the wire to confirm that it is secure.

2.2.3 External KP connection

Note: External KP levels are follows:

- Input: 5 to 12 V
- Output: 12 V

KP input

To synchronize the KP (Keying Pulse) signal from external equipment, use the #4 and #5 pins of the P22 (TRIG-I/O).

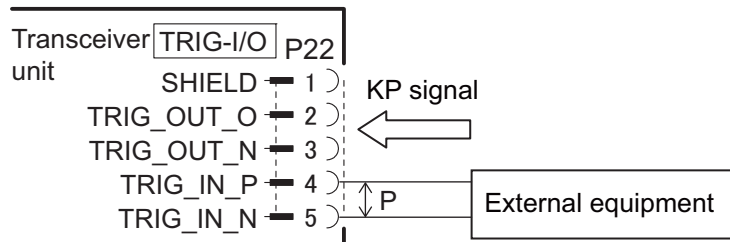

KP output

To output the KP signal from the transceiver unit to external equipment, use the #4 and #5 pins of the P22 (TRIG-I/O).

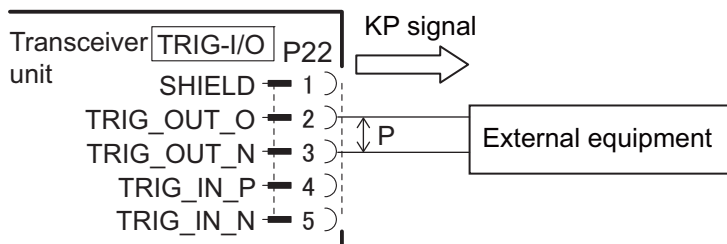

2.3 Trackball Control Unit

Connect the control unit cable to the processor unit (J1 or J2). To use the USB port on the trackball control unit, connect the unit to either one of the USB ports on the processor unit, using the supplied USB cable (TS-20-071-1). Note that the trackball control unit cannot be operated if only a USB cable is connected on the processor unit. If the USB port on the trackball control unit will not be used, the USB connection between the trackball control unit and processor unit is not required.

Connect a ground wire (IV-1.25sq., local supply) between the ground terminal and ship's ground.

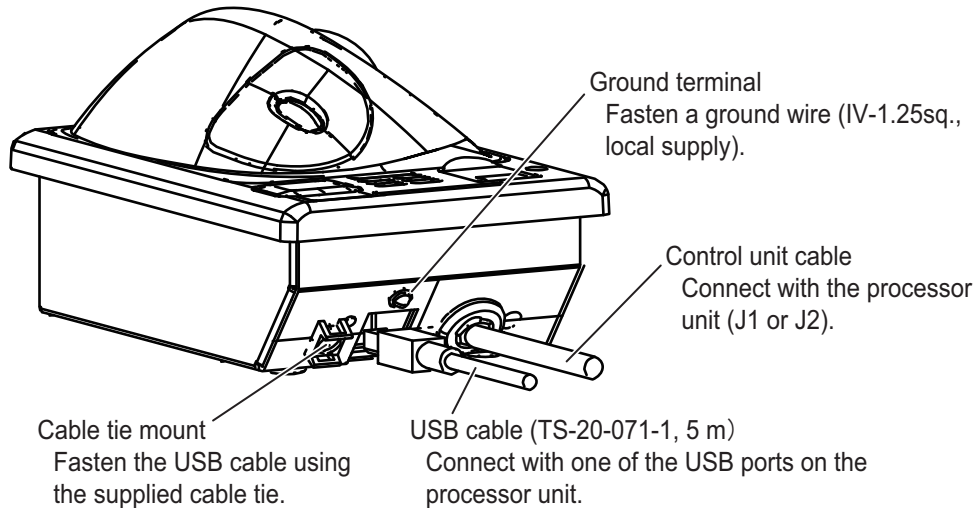

Note 1: If the USB cable is connected to the trackball control unit, fasten the USB cable to the cable tie mount using the supplied cable tie.

Note 2: The maximum cable length for USB2.0 is 5 m. To extend the USB cable, the optional DVI/USB repeater is required. If you extend the USB cable without the DVI/USB repeater, the USB device operation is not guaranteed.

Note 3: The supplied USB cable and USB port on the trackball control unit do not support USB3.0. The USB port on the trackball control unit is available, even if the supplied USB cable is connected to USB3.0 port on the processor unit. However, the data transfer speed is equivalent to USB 2.0.

Note 4: If the USB cable will not be connected to the trackball control unit, attach the supplied USB sheet to the USB port on the trackball control unit.

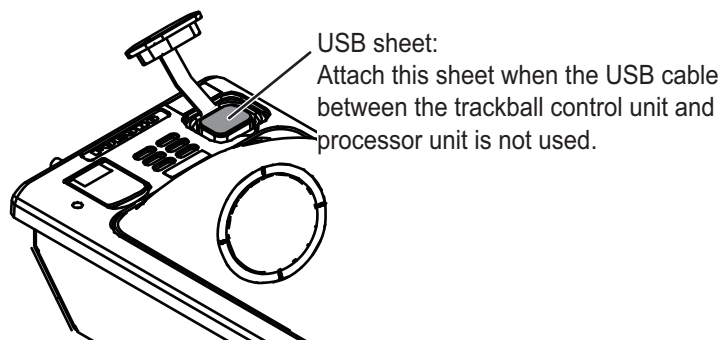

How to extend the control unit cable

To extend the length of the cable between the trackball control unit and the processor unit, use the optional cable assembly (6TPSH-XH12X2-LxxSP2, 5/10 m).

1. Unfasten four binding screws (M3×8) from the bottom of the unit, and a pan head screw (M3×8) and flat washer from the back of the unit to remove the cover.

Note: Remove the cover slowly to prevent damage to the cables connected to the circuit board in the unit.

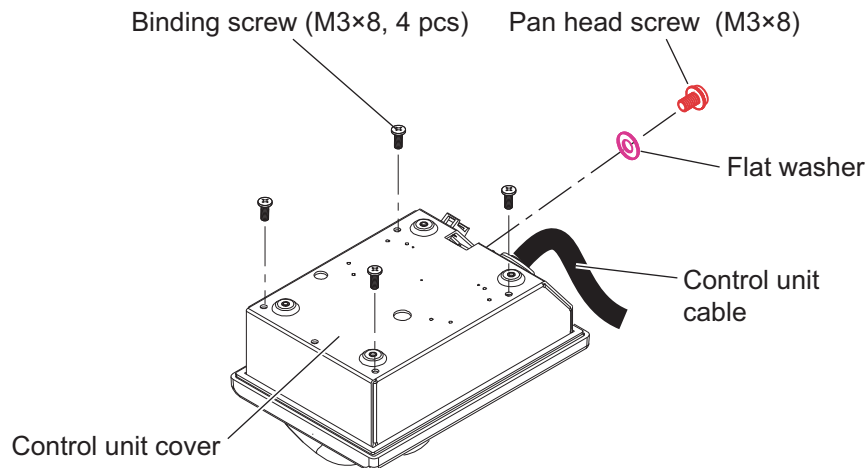

2. Unfasten the binding screws (indicated in the following figure) to remove the cable clamp from the trackball control unit, then disconnect the control unit cable from J1.

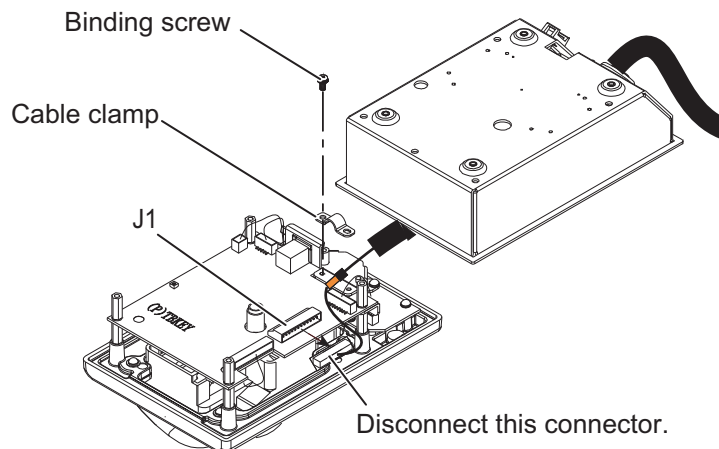

3. Pull out the control unit cable from the cover.

2. WIRING

- Pass the optional cable assembly (6TPSH-XH12X2-LxxSP2) through the cable hole on the cover.

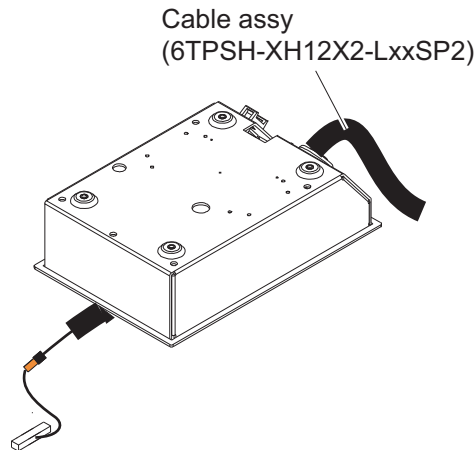

- Fasten the shield of the cable assembly with the cable clamp (removed at step 2), then connect the connector at the end of the cable assembly to the J1 connector on the circuit board.

Note: The shield of the cable must not touch the circuit board.

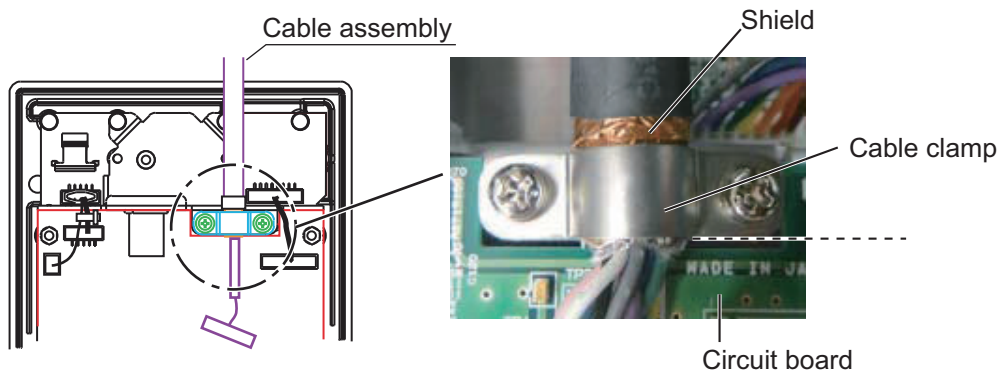

- Reattach the control unit cover.

2.4 DVI/USB Repeater (Option)

To extend the distance between the display unit and the processor unit/USB device, use the optional DVI/USB repeater. Cable extension without the repeater can result in signal loss and incorrect data display.

To access the connectors on the transmitter and receiver units, unfasten five screws and remove the protective cover. For the connections between the units, see the connection diagram on the next page.

Note 1: Make sure that the power to all components is turned off at the switchboard BEFORE connecting the DVI/USB repeater.

Note 2: The DVI/USB repeater uses DC power. If your vessel has AC power, a rectifier is required.

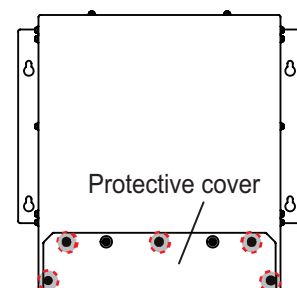

⦿ : Screws for protective cover

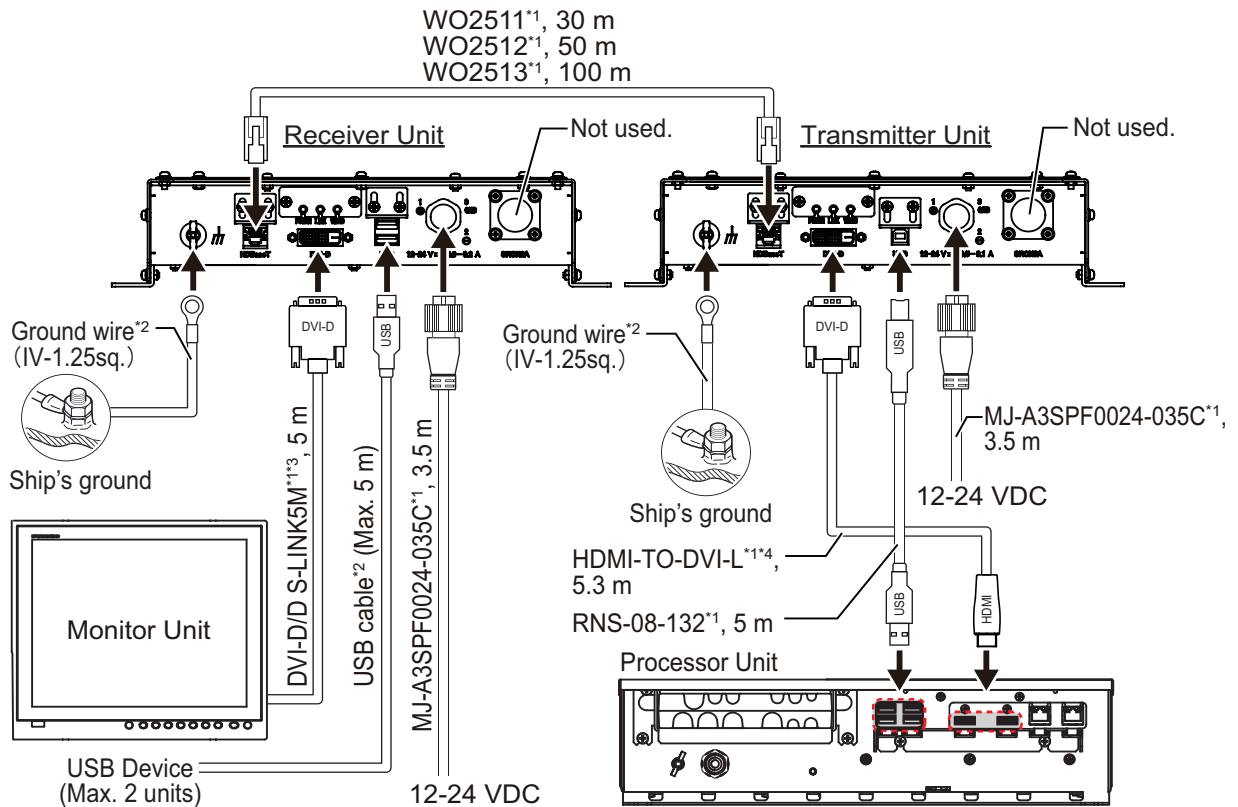

- *1: Option
- *2: Local supply
- *3: Maximum 5 m length
- *4: Maximum 5.3 m length

The LAN and USB cables must be fastened to the cable clamp, using a cable tie (local supply).

After wiring, reattach the protective cover.

Note: The cable clamp for the USB and LAN cables can be adjusted to accommodate the connectors of those cables. See the following figure.

Unfasten the indicated screws to adjust the cable clamp. Refasten the screws to secure the cable clamp after adjustment.

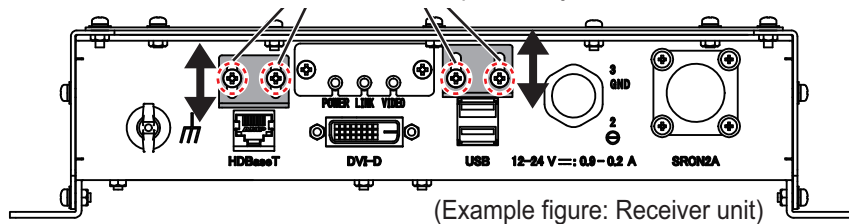

2.5 Input/Output Sentences (NMEA0183)

This equipment can input/output the following sentences:

Sentence	Data	NMEA0183 Version
Input sentences		
GGA	Global positioning system (GPS) fix data	Ver. 1.5/2.0/3.0
GLL	Geographic position - latitude/longitude	Ver. 1.5/2.0/3.0
GNS	GNSS fix data	Ver. 3.0
MTW	Water temperature	Ver. 1.5/2.0/3.0
VHW	Water speed and heading	Ver. 1.5/2.0/3.0
VTG	Course over ground and ground speed	Ver. 1.5/2.0/3.0
ZDA	Time and date	Ver. 1.5/2.0/3.0
GPatt	FURUNO proprietary sentence	-
GPhve	FURUNO proprietary sentence	-
pireq	FURUNO proprietary sentence	-
IIDAD	Proprietary sentence of other company	-
IIDBS	Proprietary sentence of other company	-
IIHFB	Proprietary sentence of other company	-
IITPC	Proprietary sentence of other company	-
IITPT	Proprietary sentence of other company	-
MPMSD	Proprietary sentence of other company	-
SDDBS	Proprietary sentence of other company	-
SDfnz	FURUNO proprietary sentence	-
Output sentences		
DBS	Depth below surface	Ver. 1.5
DBT	Depth below transducer	Ver. 1.5/2.0/3.0
DPT	Depth	Ver. 2.0/3.0
MTW	Water temperature	Ver. 1.5/2.0/3.0
TLL	Target latitude and longitude	Ver. 3.0
SDes1	FURUNO proprietary sentence	-
SDes2	FURUNO proprietary sentence	-
SDesd	FURUNO proprietary sentence	-
SDflg	FURUNO proprietary sentence	-
SDmrk	FURUNO proprietary sentence	-
pidat	FURUNO proprietary sentence	-

3. INITIAL SETTINGS

This chapter covers the initial setup of the equipment.

3.1 Initial Setting Menu

After mounting and wiring the equipment, press the power key () on the trackball control unit to turn the system on. The first time the system is powered and after restoring factory default settings, the initial setting menu appears.

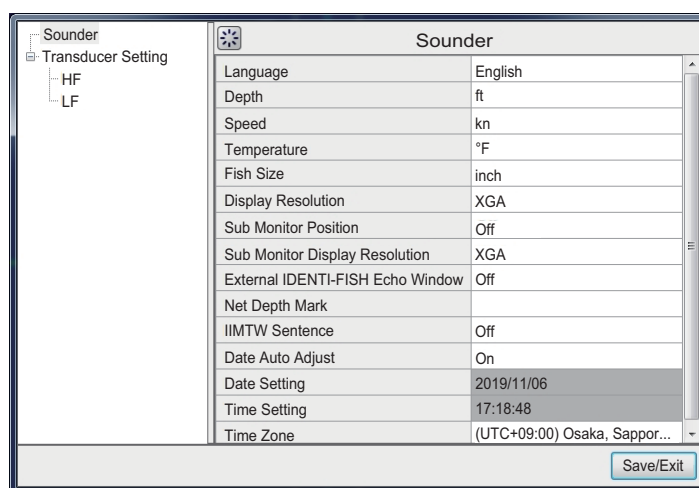

Do the following procedure to set up the initial setting menu.

1. Select the appropriate language from the [Language] pull-down list.
2. Select the measurement units from [Depth], [Speed], [Temperature] and [Fish Size] pull-down lists.

Menu Item	Meaning	Unit
[Depth]	Water depth	m (meters), ft (feet), fm (fathoms), ㇇㇆*, pb (passi/braza)
[Speed]	Ship's speed	kn, km/h, mph
[Temperature]	Water temperature	°C, °F
[Fish Size]	Fish length	cm, inch

*: Japanese unit of depth measurement.

3. Select the display resolution of the monitor unit that is connected to HDMI1 port from the [Display Resolution] pull-down list.

Note: Be sure to set the display resolution according to the resolution of the monitor unit.

- [XGA]: 1024×768
- [SXGA]: 1280×1024
- [UXGA]: 1600×1200
- [Full HD]: 1920×1080
- [WUXGA]: 1920×1200

For sub monitor settings, go to step 4. If no sub monitor is connected, go to step 7.

4. Select the sub monitor position (left/right) from the [Sub Monitor Position] pull-down list.

3. INITIAL SETTINGS

5. Select the display resolution of the sub monitor that is connected to HDMI2 port from the [Sub Monitor Display Resolution] pull-down list.
 - [XGA]: 1024×768
 - [SXGA]: 1280×1024
 - [UXGA]: 1600×1200
 - [Full HD]: 1920×1080
 - [WUXGA]: 1920×1200
6. To display the IDENTI-FISH™ echo window on the sub monitor, select the [External IDENTI-FISH Echo Window] to [On]. When [Off] is selected, you can drag the graph window, etc. to the sub monitor. Echoes are not displayed on the sub monitor.
7. When a net sonde is connected, click the  button for [Net Depth Mark] to open the [Mark ID] window. When not connected, go to step 9.

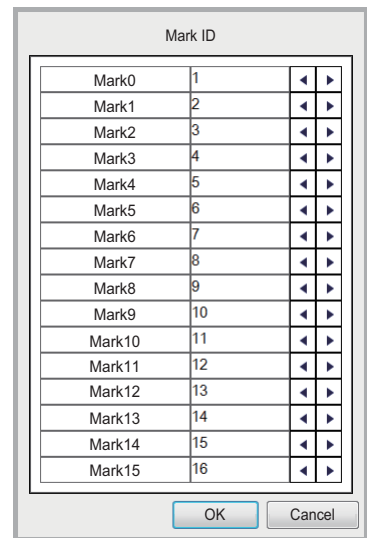

8. Assign the net sonde ID to a net mark (0 to 15), then click the [OK] button.

Note: Assign a different net sonde ID to each net mark. If the duplicate IDs are found, the message to the right appears.

9. When the Simrad ITI net sensor is connected, select [ITI Net Sensor] from the [IIMTW Sentence] pull-down list. When not connected, select [Off] or [Water Temperature Gauge].

Note: The following net sensors are compatible with this equipment.

Manufacturer	Model
Marport	TE-155
Imaginex	TS-337A
Simrad	ITI System

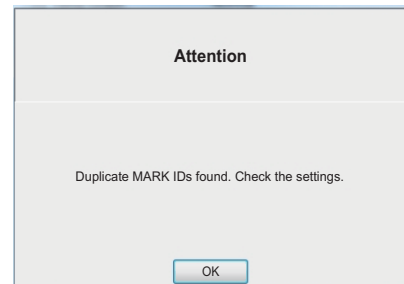

10. Select [On] or [Off] from the [Date Auto Adjust] pull-down list.
 - [Off]: Manually set the system time.
 - [On]: The system time is automatically adjusted according to the date from the navigation equipment.

When [Off] is selected, go to step 11. Otherwise, go to step 13.

11. Click the  button for [Date Setting] to open the [Date Setting] window, then enter the appropriate date manually and click the [OK] button.

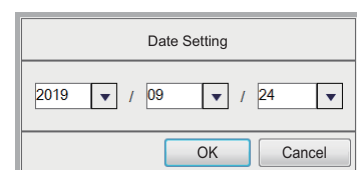

12. Click the  button for [Time Setting] to open the [Time Setting] window, then enter the appropriate time manually and click the [OK] button.
13. Select the appropriate time zone from the [Time Zone] pull-down list.
14. Select [HF] from the menu on the left-hand side of the window.

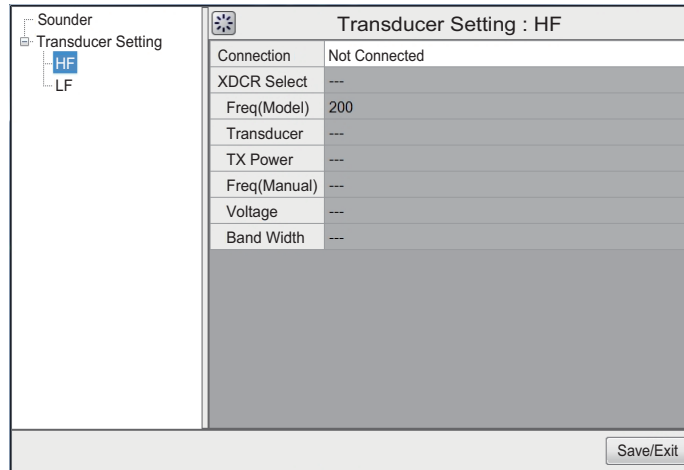
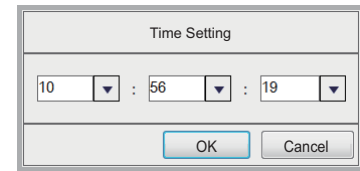

15. Set up the HF (high frequency) transducer, referring to the following table.

Menu item	Description
[Connection]	Set the presence of the transducer connection ([Connected]/[Not Connected]). When [Connected] is selected, set up the following menu items.
[XDCR Select]	Select the setting method of the transducer. <ul style="list-style-type: none"> • [TD-ID]: When a TD-ID transducer is connected. • [Model]: Select the transducer model. • [Manual]: Manually input the transducer information. Note: For the [Model] and [Manual] setting, it may be necessary to apply an offset to fish size (length) if the calculated and actual fish sizes are different, to get accurate data for the fish size histogram. For details of the [Fish Size] menu see the operator's manual.
[Freq (Model)]	Select the central frequency of the transducer (38, 50, 107 or 200 kHz). This menu item is enabled when [XDCR Select] is set to [Model]. If [TD-ID] is selected, the frequency is automatically entered.
[Transducer]	Select the model number of the transducer. This menu item is enabled when [XDCR Select] is set to [Model]. If [TD-ID] is selected, the model number is automatically entered.
[TX Power]	The TX power of the transducer automatically appears according to the model number. The setting is fixed. The value is shown only when [XDCR Select] is set to [Model] or [TD-ID].
[Freq (Manual)]	Manually set the frequency of the transducer (setting range: 15 to 200 kHz). This menu item is enabled when [XDCR Select] is set to [Manual].
[Voltage]	Set the transmission voltage of the transducer (unit: V). The setting range depends on the setting value for [Freq (Manual)]. This menu item is enabled when [XDCR Select] is set to [Manual]. If [TD-ID] or [Model] is selected, the voltage is automatically entered and the setting is fixed.
[Band Width]	Set the band width of the transducer (unit: kHz). The setting range depends on the setting value for [Freq (Manual)]. This menu item is enabled when [XDCR Select] is set to [Manual].

3. INITIAL SETTINGS

16. Select [LF] from the menu on the left-hand side of the window, then set up the LF (low frequency) transducer in a similar manner.
17. Click the [Save/Exit] button.
The following confirmation message appears if the transducer settings are correct.

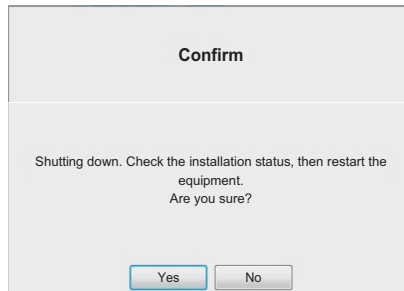

Note: If the transducer settings are not correct, the following message appears. Click the [OK] button to close the message, then confirm the transducer settings.

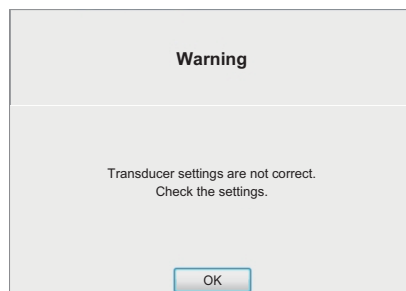

18. Click the [Yes] button to turn the system off, then turn the system on.



3.2 How to Set the Service Menu

3.2.1 How to open the service menu

1. Click the  button at top-left corner to show the InstantAccess bar™ when the InstantAccess bar™ is hidden.

To hide the InstantAccess bar™, click the  button or right-click with trackball control unit anywhere on the screen.



2. Click the [Settings] icon () from the InstantAccess bar™, then click the [Advanced Settings] icon ().
3. Select [Service] from the menu on the left-hand side of the window.

The message "Ask your dealer to change service settings." appears.

4. Press and hold the [OK] button for approx. 10 seconds to open the service menu.

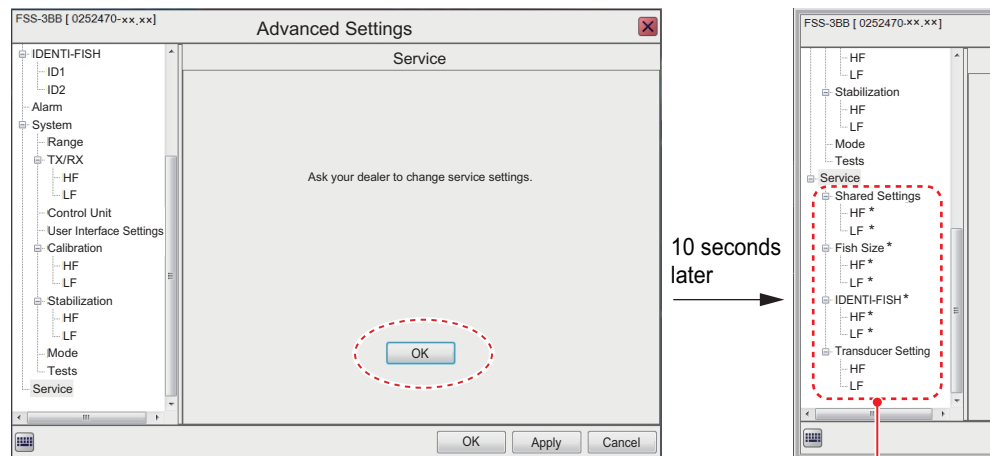

Unlocked service menu items.

*: Not used at installation.

5. Follow the procedures in the remaining sections of this chapter to set up the FSS-3BB.

To hide the service menu, click the [OK] button again. The message "Ask your dealer to change service settings." is shown. The service menu is also hidden when the system is rebooted.

3. INITIAL SETTINGS



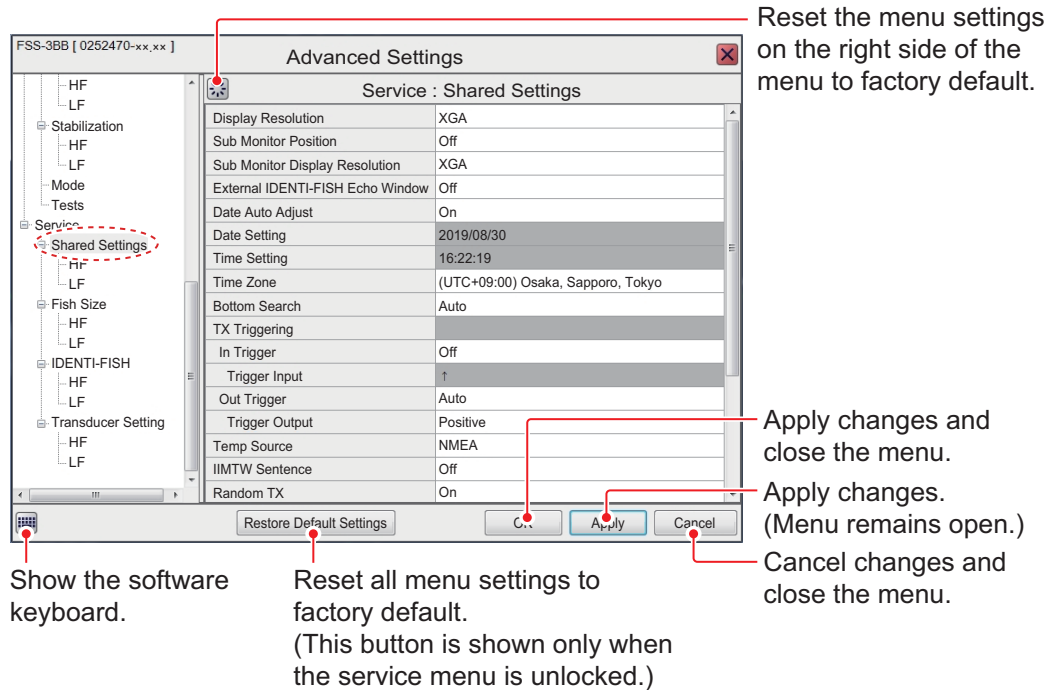

3.2.2 [Shared Settings] menu

Set the monitors, KP control signals, etc. on the [Shared Settings] menu.

To access the [Shared Settings] menu, open the service menu referring to section 3.2.1 and select [Shared Settings] from the menu on the left-hand side of the window.

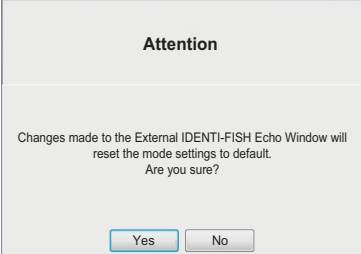

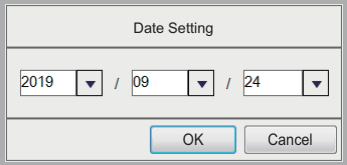
Menu item	Description
[Display Resolution] ^{*1, *2}	Select the display resolution of the monitor unit that is connected to HDMI1 port. <ul style="list-style-type: none"> • [XGA]: 1024×768 • [SXGA]: 1280×1024 • [UXGA]: 1600×1200 • [FullHD]: 1920×1080 • [WUXGA]: 1920×1200
[Sub Monitor Position] ^{*1, *2}	Select the sub monitor position (left/right). When the sub monitor is not connected, select [Off].
[Sub Monitor Display Resolution] ^{*1, *2}	Select the display resolution of the sub unit that is connected to HDMI2 port. <ul style="list-style-type: none"> • [XGA]: 1024×768 • [SXGA]: 1280×1024 • [UXGA]: 1600×1200 • [FullHD]: 1920×1080 • [WUXGA]: 1920×1200

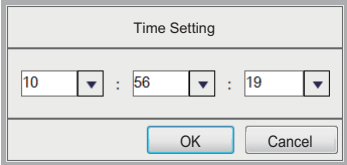
Menu item	Description
[External IDENTI-FISH Echo Window] ^{*1, *2}	<p>This menu item is available when [Sub Monitor Position] is set to other than [Off]. To display the IDENTI-FISH™ echo window on the sub monitor, select [On]. When [Off] is selected, you can drag the graph window, etc. to the sub monitor. Echoes are not displayed on the sub monitor.</p> <p>Note: To change this setting item, reset the mode settings to the factory default. The following message appears. Click the [Yes] button to reset the mode settings. For details about the mode settings, see the operator's manual.</p> <div data-bbox="903 584 1265 837" style="text-align: center;">  </div>
[Date Auto Adjust] ^{*1}	<p>Select [On] to automatically adjust the date and time at system start-up. Select [Off] to manually adjust the date and time as required.</p>
[Date Setting] ^{*1}	<p>Click the  button to open the [Date Setting] window. Enter the appropriate date for the system time, then click the [OK] button. This menu item is enabled when [Date Auto Adjust] is set to [Off].</p> <div data-bbox="911 1133 1259 1296" style="text-align: center;">  </div>
[Time Setting] ^{*1}	<p>Click the  button to open the [Time Setting] window. Enter the appropriate time for the system time, then click the [OK] button. This menu item is enabled when [Date Auto Adjust] is set to [Off].</p> <div data-bbox="911 1464 1259 1628" style="text-align: center;">  </div>
[Time Zone] ^{*1, *2}	<p>Select the appropriate time zone from the pull-down list.</p>
[Bottom Search]	<p>Not used at installation.</p>
[TX Triggering]	
[In Trigger]	<p>Select [On] to synchronize the KP (Keying Pulse) signal from the external equipment that is connected to the TRIG-I/O port on the transceiver unit.</p>

3. INITIAL SETTINGS

Menu item	Description								
[Trigger Input]	Select the reaction to a KP signal that is input from the external equipment. This menu item is enabled when [In Trigger] is set to [On]. <ul style="list-style-type: none"> [↑]: Operates in response to the detection of a rising edge. [↓]: Operates in response to the detection of a falling edge. 								
[Out Trigger]	The FSS-3BB outputs the KP signal when HF or LF echo is transmitted. Select [Auto] to switch the KP signal output settings.								
[Trigger Output]	Select the polarity ([Positive] or [Negative]) of the KP signal that is output from the FSS-3BB to the external equipment.								
[Temp Source]	Select the data source of the water temperature data. <ul style="list-style-type: none"> [NMEA]: Use the data that is input from the NMEA0183 equipment. [Transducer]: Use the data from the transducer. 								
[IIMTW Sentence]* ¹	When the Simrad ITI net sensor is connected, select [ITI Net Sensor] from the [IIMTW Sentence] pull-down list. When not connected, select [Off] or [Water Temperature Gauge]. Note: The following net sensors are compatible with this equipment. <table border="1" data-bbox="826 994 1275 1164"> <thead> <tr> <th>Manufacturer</th> <th>Model</th> </tr> </thead> <tbody> <tr> <td>Marport</td> <td>TE-155</td> </tr> <tr> <td>Imaginex</td> <td>TS-337A</td> </tr> <tr> <td>Simrad</td> <td>ITI System</td> </tr> </tbody> </table>	Manufacturer	Model	Marport	TE-155	Imaginex	TS-337A	Simrad	ITI System
Manufacturer	Model								
Marport	TE-155								
Imaginex	TS-337A								
Simrad	ITI System								
[Random TX]	Not used at installation.								
[White Marker]									
[TruEcho CHIRP]									
[Bottom Noise Rejector]									
[PRC Settings]									
[Input PRC Settings]									
[Export PRC Settings]									
[Update PRC Settings]									

*1: The corresponding setting on the initial setting menu takes precedence.

*2: System reboot is required to apply the settings. The following confirmation message appears. Click the [Yes] button to reboot the system. A buzzer sounds during the system reboot because the communication between the processor unit and the trackball control unit is disconnected temporarily. The buzzer is stopped after completing the system reboot.

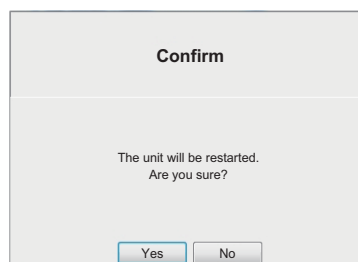

3.2.3 [Transducer Setting] menu

Set up the HF and LF transducers on the [Transducer Setting] menu. The settings that are entered on the initial setting menu are applied to the [Transducer Setting] menu.

To access the [Transducer Setting] menu, open the service menu referring to section 3.2.1 and select [Transducer Setting] from the menu on the left-hand side of the window.

The following display example is for the HF transducer. The menu items for the LF transducer are same as the HF transducer.

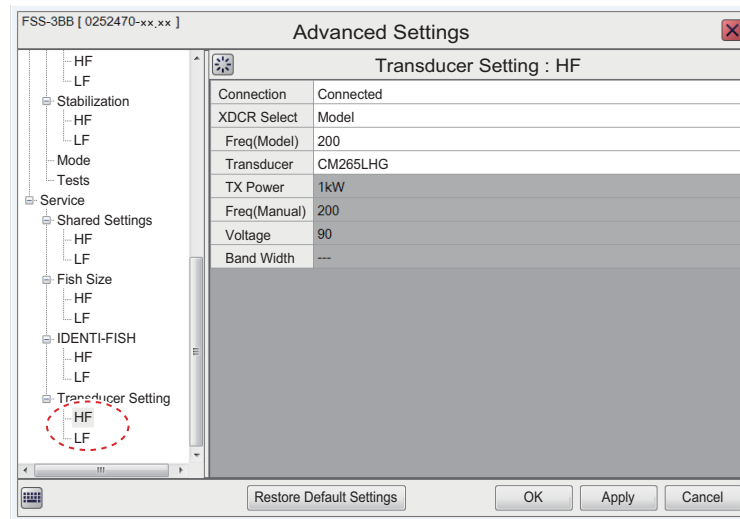

Note: If a transducer is replaced with a different transducer, change the transducer settings **BEFORE** replacing the transducer.

Menu item	Description
[Connection]	Set the presence of the transducer connection ([Connected]/[Not Connected]). When [Connected] is selected, set up the following menu items.
[XDCR Select]	Select the setting method of the transducer. <ul style="list-style-type: none"> • [TD-ID]: When a TD-ID transducer is connected. • [Model]: Select the transducer model. • [Manual]: Manually input the transducer information. Note: For the [Model] and [Manual] setting, it may be necessary to apply an offset to fish size (length) if the calculated and actual fish sizes are different, to get accurate data for the fish size histogram. For details of the [Fish Size] menu see the operator's manual.
[Freq (Model)]	Select the central frequency of the transducer (38, 50, 107 or 200 kHz). This menu item is enabled when [XDCR Select] is set to [Model]. If [TD-ID] is selected, the frequency is automatically entered.
[Transducer]	Select the model number of the transducer. This menu item is enabled when [XDCR Select] is set to [Model]. If [TD-ID] is selected, the model number is automatically entered.
[TX Power]	The TX power of the transducer automatically appears according to the model number. The setting is fixed. The value is shown only when [XDCR Select] is set to [Model] or [TD-ID].
[Freq (Manual)]	Manually set the frequency of the transducer (setting range: 15 to 200 kHz). This menu item is enabled when [XDCR Select] is set to [Manual].

3. INITIAL SETTINGS

Menu item	Description
[Voltage]	Set the transmission voltage of the transducer (unit: V). The setting range depends on the setting value for [Freq (Manual)]. This menu item is enabled when [XDCR Select] is set to [Manual]. If [TD-ID] or [Model] is selected, the voltage is automatically entered and the setting is fixed.
[Band Width]	Set the band width of the transducer (unit: kHz). The setting range depends on the setting value for [Freq (Manual)]. This menu item is enabled when [XDCR Select] is set to [Manual].

Note 1: If the transducer settings are not correct, the following message appears. Click the [OK] button to close the message, then confirm the transducer settings.

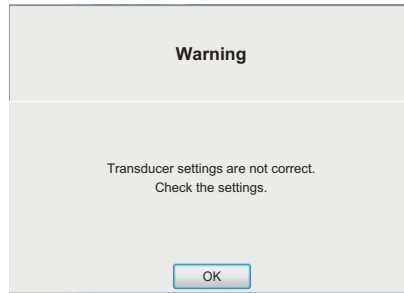

Note 2: If you select a transducer that does not support the IDENTI-FISH™ while the IDENTI-FISH™ feature is enabled, the following confirmation message appears.

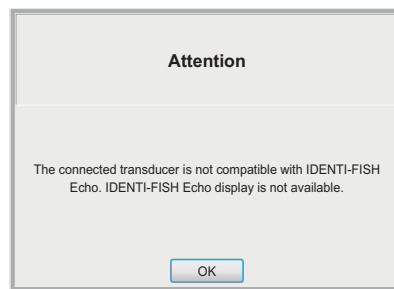

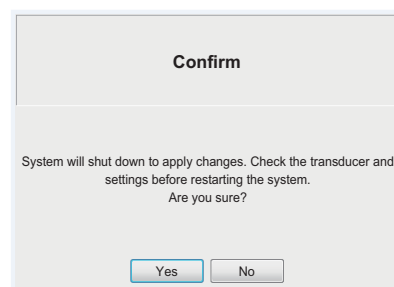

Note 3: System reboot is required to apply the transducer settings. The following confirmation message appears. The equipment is automatically shut down after clicking the [Yes] button. After completing the shut down, turn the transceiver unit off, then replace the transducer. After replacing the transducer, reboot the system.



3.3 Communication Port Setting

To set the communication port (NMEA1 to NMEA5), do the following.

1. Click the [Settings] icon () from the InstantAccess bar™, then click the [Advanced Settings] icon ().
2. Select the [Tests] from the menu on the left-hand side of the window. The [Tests] menu appears on the right-hand side of the window.

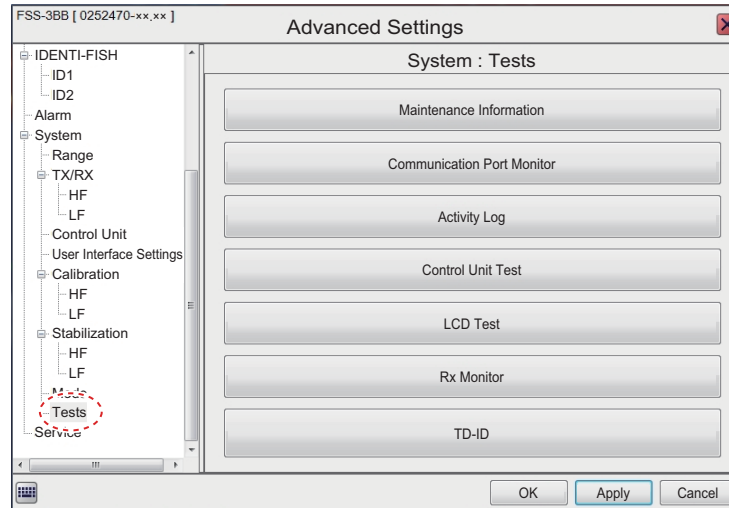

3. Select the [Communication Port Monitor] from the [Tests] menu. The communication port monitor window appears.

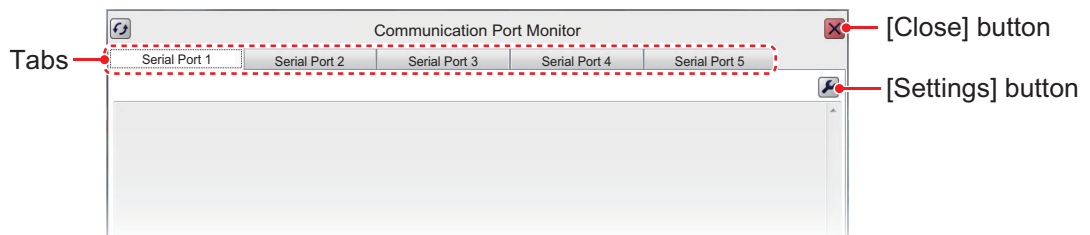

4. Select a port tab ([Serial Port 1] to [Serial Port 5]) to show the corresponding port.
5. Click the [Settings] button () to show the port setting menu.

Serial Port 1	
NMEA Fromat	Ver1.5
Output Data	Depth
TLL Output	TLL
Echo Start Depth	0
Output Echo Cycle	1.0
Echo Resolution	Auto
Manual	0.1
Echo Data Format	Peak
Baud Rate	4800

OK Apply Cancel

3. INITIAL SETTINGS

6. Set the menu items, referring to the following table.

Menu item	Description
[NMEA Format]	Select a NMEA format among Ver 1.5, Ver 2.0, Ver 3.0, Echo. Note 1: When the NMEA format is changed, the defaults settings are restored for the items in the same window. Note 2: The [Echo] setting is intended for use by researchers. Do not select the setting unless applicable. The NMEA outputs echo data (baud rate: 38400, 57600 or 115200 bps), however data from the navigation equipment cannot be received.
[Output Data]	Select output data to the navigation equipment that is compatible with FURUNO TLL. You can select more than one datum. <ul style="list-style-type: none"> • [Depth]: Output the depth data. • [Temperature]: Output the water temperature* data. • [Fish Size]: Output the fish size data. This function requires the baud rate be set to 38400 bps.
[TLL Output]	Select a TLL output data to the navigation equipment. <ul style="list-style-type: none"> • [Off]: No output of the longitude/latitude data. • [TLL]: Output the longitude/latitude* data. • [FURUNO-TLL]: Output the longitude/latitude* data and the data that is selected at [Output Data]. This function requires the connection with the navigation equipment that is compatible with FURUNO TLL.
[Echo Start Depth]	Not used. The setting is fixed.
[Output Echo Cycle]	
[Echo Resolution]	
[Manual]	
[Echo Data Format]	
[Baud Rate]	Select a baud rate (4800 or 38400 bps). Note: Select “38400 bps” when the [TLL Output] is set to [FURUNO-TLL]. “4800 bps” may slow the transmission of sentences.

*: These output data require appropriate external data input.

7. Click the [OK] button to close the port setting menu.
8. Click the [Close] button (✖) to close the communication port monitor window.

Communication port monitor

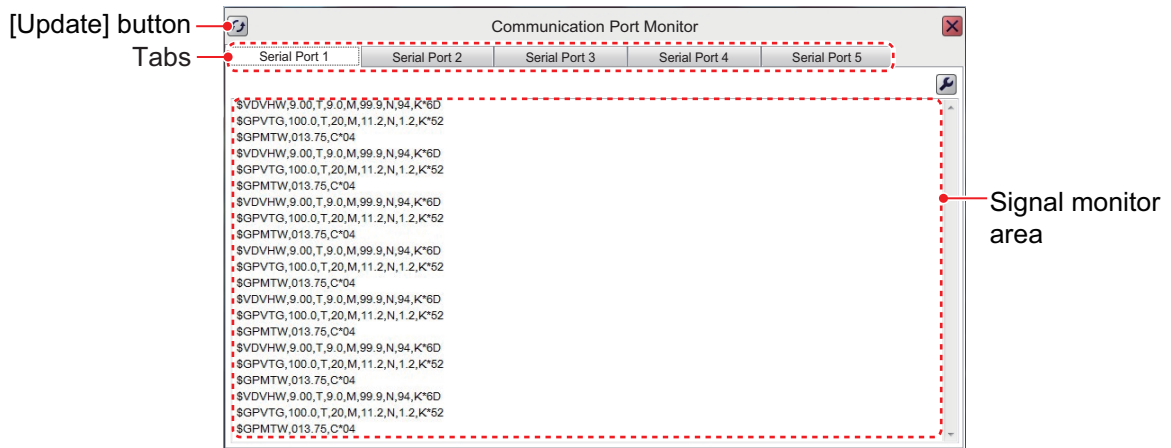

The serial signal monitor is available for each port.

Select the port tab from the communication port monitor window, then click the [Update] button () to display the received data for selected port.



3.4 [Calibration] Menu

The [Calibration] menu allows you to calibrate various settings.

1. Click the [Settings] icon () from the InstantAccess bar™, then click the [Advanced Settings] icon ().
2. Select the [Calibration] from the menu on the left-hand side of the window. The [Calibration] menu appears on the right-hand side of the window.

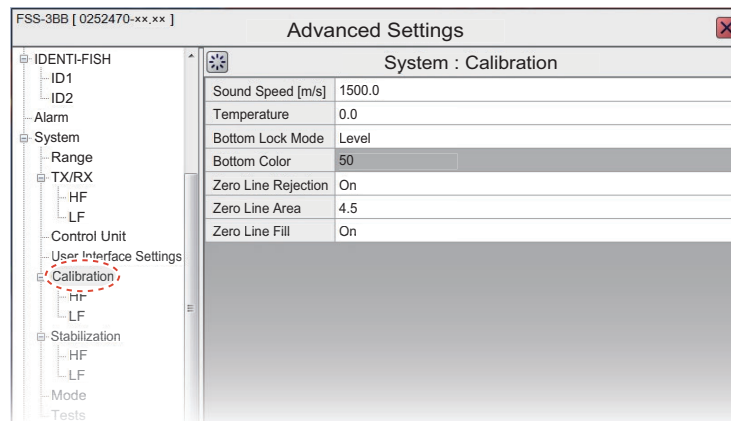

3. Set the menu items, referring to the following table.

Menu item	Description
[Sound Speed [m/s]]	Adjust the sound velocity of the TX/RX signal if the depth indication is incorrect, because of water temperature of salinity density (setting range: -200.0 to +2000.0 m/s).
[Temperature]	If the water temperature indication is wrong, you can correct it here (setting range: -35.0 to +35.0°F). For example, if the water temperature indication is 2°F higher than actual water temperature, enter “-2°F”.

3. INITIAL SETTINGS

Menu item	Description
[Bottom Lock Mode]	Set how the bottom edge is determined, by signal level or display color. <ul style="list-style-type: none"> [Level]: Determine the bottom edge by signal level. When the method is [Color], bottom fish may be hidden in the bottom edge. With [Level] the shape of the bottom echo may change depending on the bottom contour of the bottom. [Color]: Determine the bottom edge by display color. When bottom fish are well separated from the bottom, the bottom is displayed with a straight line, making discrimination of bottom fish easier. However, the bottom presentation may change depending on gain setting. When set to Color, select the color (0-63) to be judged as the bottom echo.
[Bottom Color]	This menu item is available when [Bottom Lock Mode] is set to [Color]. The higher the setting, the strong color echo (reddish brown, red) is recognized as the bottom.
[Zero Line Rejection]	Turn the zero line (transmission line) on or off. When turned on, the transmission line disappears, which allows you to see fish echoes near the surface clearly. The length of the transmission line changes with the transducer used and installation characteristics. If the width of the transmission line is 4.5 ft or more, set the transmission line width with [Zero Line Area].
[Zero Line Area]	This feature adjusts the transmission line so that the transmission line disappears when the menu item [Zero Line Rejection] is turned on. For a long tail, increase the value (setting range: 4.5 to 9.8 ft). If the transmission line does not disappear, lower the TX power.
[Zero Line Fill]	Turn off to see fish echoes within 1 m from the surface.

4. Select [HF] from the menu on the left-hand side of the window.

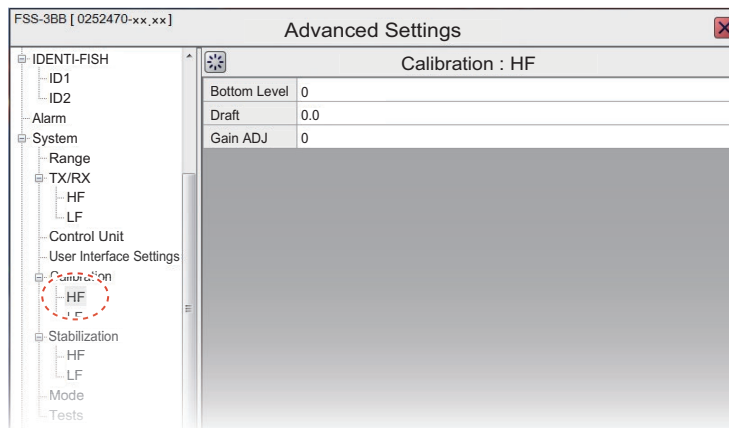

5. Set the menu items, referring to the following table.

Menu item	Description
[Bottom Level]	In the default bottom level setting (+0), the equipment judges consecutive strong echoes to be bottom echoes. If, in that setting, the depth indication is unstable, adjust the bottom level (setting range: -40 to +40). If vertical lines extend upward from the bottom echo in the bottom lock display, lower the bottom level to erase the vertical lines. If the level is too low, however, it may be difficult to distinguish bottom fish from the bottom echo.

Menu item	Description
[Draft]	The default depth display shows the distance from the transducer. If you would rather show the distance from the sea surface, set your ship's draft (setting range: -30.0 to +99.9 ft). The draft line for HF and LF can be set respectively. If the draft settings for HF and LF do not match, the message "The setting values are different for HF and LF. If you don't use an integrated transducer, the measurement accuracy of the Fish Size Graph and ID Graph will be reduced." appears.
[Gain ADJ]	Adjust this setting if the gain is too high or too low, or the gain for the low and high frequencies appears unbalanced, you can compensate it here (setting range: -50 to +50).

6. Select [LF] from the menu on the left-hand side of the window, then set up the LF (low frequency) transducer in a similar manner.
7. Click the [OK] button to apply the settings and close the menu.

3.5 [Stabilization] Menu



The [Stabilization] menu compensates for the effects of heaving, and requires a SATELLITE COMPASS™.

Note 1: The heaving feature requires the connection with a SATELLITE COMPASS™. The heaving feature is not available when there is no data from a SATELLITE COMPASS™.

Note 2: Set the SATELLITE COMPASS™ output as follows. Refer to respective operator's manual for setting details.

- Output sentence: ATT (GPatt), HVE (GPhve)
- Baud rate: 38,400 bps
- Transmission rate: 25 ms or less
- IEC edition version setting (SC-50/SC-110 only): IEC ED1

Note 3: The heaving feature is not available when [In Trigger] on the [Shared Settings] menu (see section 3.2.2) is set to [On].

1. Click the [Settings] icon () from the InstantAccess bar™, then click the [Advanced Settings] icon ().

3. INITIAL SETTINGS

2. Select [Stabilization] from the menu on the left-hand side of the window. The [Stabilization] menu appears on the right-hand side of the window.

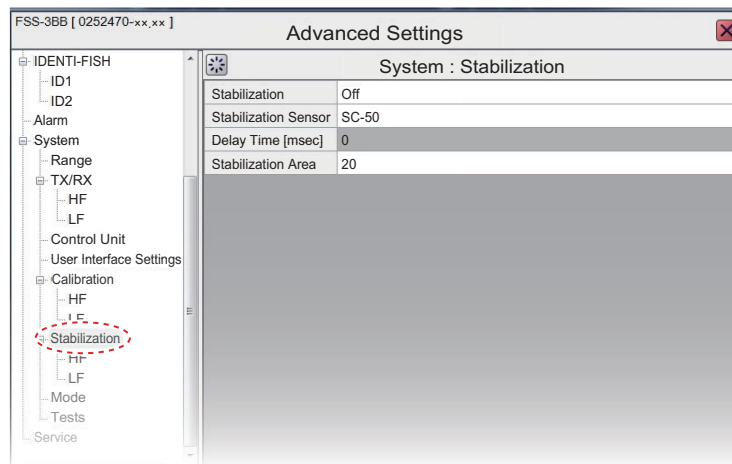

3. Set the menu items, referring to the following table.

Menu item	Description
[Stabilization]	Turn heaving compensation on or off. Turn it on when seas are rough, to get stable echoes. When turned on, the stabilization icon () appears in the [Picture Advance] section of the header.
[Stabilization Sensor]	Select the model of the SATELLITE COMPASS™. If [Manual] is selected, adjust [Delay Time [msec]].
[Delay Time [msec]]	Adjust the delay time of the sensor (setting range: 0 to 300 ms). This menu item is available when [Stabilization Sensor] is set to [Manual]. <ul style="list-style-type: none"> • For SC-50/SC-110: Set to “200 msec”. • For other models: Set to “50 msec”.
[Stabilization Area]	When heaving exceeds the value set here, stabilization is stopped and the stabilization icon at the top of the screen is displayed with an “x”, indicating it has stopped (setting range: 0 to 20 m). However, the setting for [Stabilization] is kept [On]. When heaving is once again less than the value set here, stabilization is restarted and the “x” disappears.

4. Select the [HF] from the menu on the left-hand side of the window.

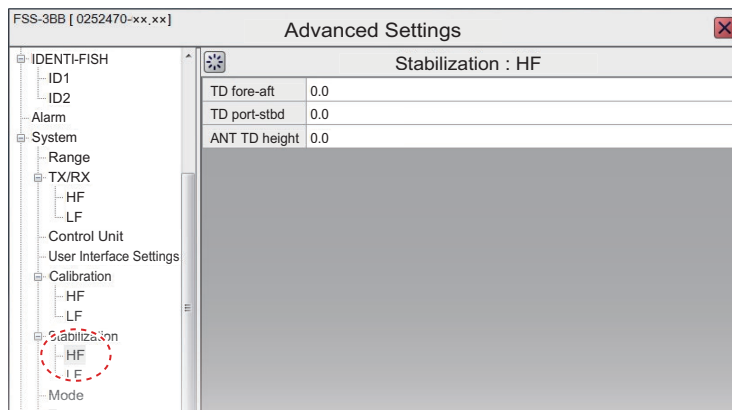

5. Set the antenna position of the SATELLITE COMPASS™.

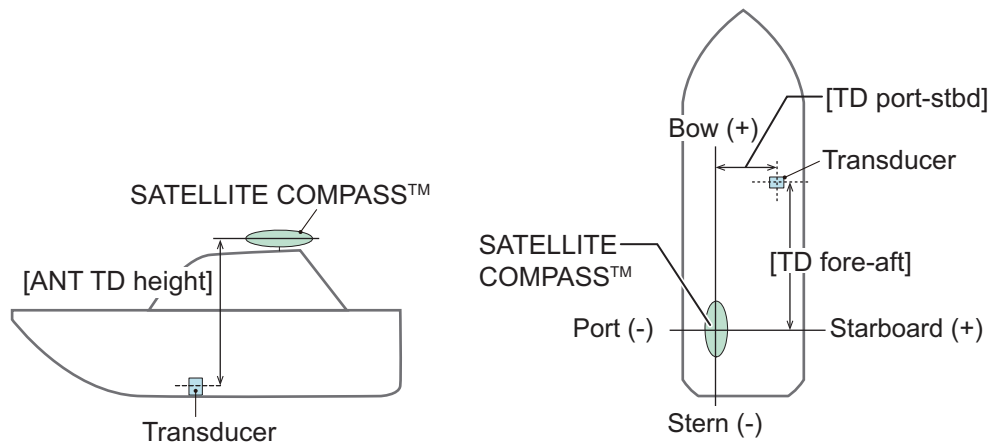



- [TD fore-aft]: Distance from antenna to transducer on the fore-aft line (setting range: -100.0 to +100.0 m). Enter to a positive value for a fore-side transducer, a negative value for an aft-side transducer.
- [TD port-stbd]: Distance from antenna to transducer on the port-stbd line (setting range: -100.0 to +100.0 m). Enter a positive value for starboard-side transducer, a negative value for a port-side transducer.
- [ANT TD height]: Vertical distance between the antenna and the transducer (setting range: 0.0 to 100.0 m).

If the position settings for HF and LF do not match, the message “The setting values are different for HF and LF. If you don't use an integrated transducer, the measurement accuracy of the Fish Size Graph and ID Graph will be reduced.” appears.

6. Select [LF] from the menu on the left-hand side of the window, then set up the LF (low frequency) transducer in a similar manner.
7. Click the [OK] button to apply the settings and close the menu.

3.6 How to Take a Still Image of the RX Monitor

After the installation, take a still image of the RX monitor screen when the [Default Setting] checkbox is checked, in a harbor test. The still image of the RX monitor screen is used for checking the equipment in maintenance.

1. Click the [Settings] icon () from the InstantAccess bar™, then click the [Advanced Settings] icon ().
2. Select the [Tests] from the menu on the left-hand side of the window. The [Tests] menu appears on the right-hand side of the window.
3. Select the [Rx Monitor] from the [Tests] menu. The RX monitor screen appears.
4. Check the checkbox for [Default Setting].

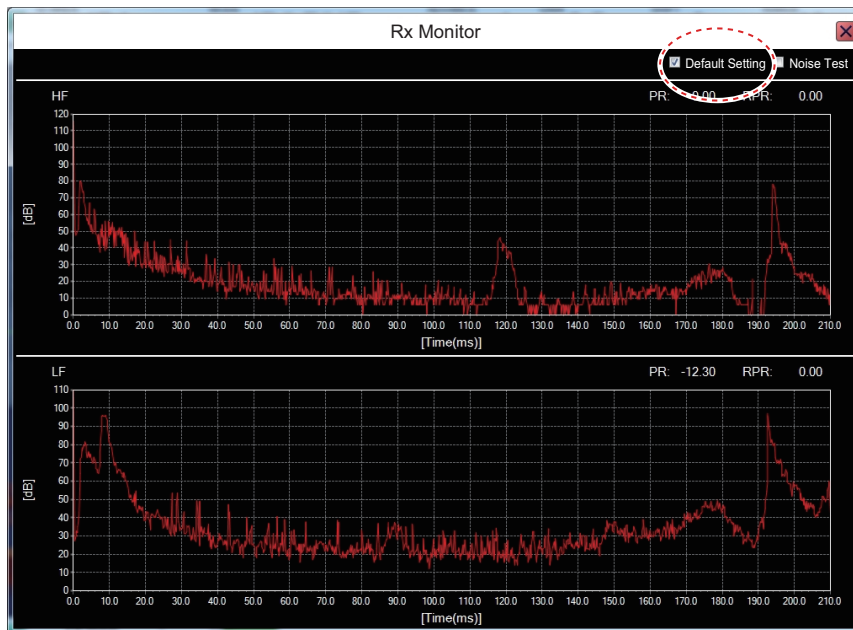

5. Press the wheel on the trackball to take a still image.
6. Click the [Close] button () to close the RX monitor screen.
7. Press and hold the scrollwheel on the trackball control unit to open the replay screen, then confirm that the still image that of the RX monitor screen is saved correctly.



3.7 Model Data for the IDENTI-FISH™ Graph

The FSS-3BB compares the histograms of schools of fish with the model data within the measurement range, and indicates the similarity of fish species by numerical values and bar graphs*. This graph is called the “IDENTI-FISH™ graph”. Only model data of mackerel and herring are stored in the FSS-3BB. For how to set model data and register fish species, see the operator’s manual (OME-23930).

*: Requires the transducer compatible with the IDENTI-FISH™ feature.

3.8 Reset to Default Setting

To reset all customized settings to factory default settings, do the following procedure. Note that the customized settings cannot be restored.

1. Click the [Settings] icon () from the InstantAccess bar™, then click the [Advanced Settings] icon ().
2. Select [Service] from the menu on the left-hand side of the window. The message "Ask your dealer to change service settings." appears.
3. Press and hold the [OK] button for approx. 10 seconds to open the service menu.
4. Click the [Restore Default Settings] button. The following confirmation message appears.

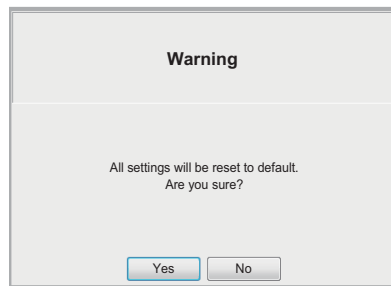

5. Click the [Yes] button to restore factory default settings. The equipment is automatically turned off. After the shutdown, press the power key () on the trackball control unit to turn the system on. The initial setting menu appears after restoring factory default settings and rebooting the system. Set up the initial setting menu, referring to section 3.1.

3. INITIAL SETTINGS

This page is intentionally left blank.

APPX. 1 JIS CABLE GUIDE

Cables listed in the manual are usually shown as Japanese Industrial Standard (JIS). Use the following guide to locate an equivalent cable locally.

JIS cable names may have up to 6 alphabetical characters, followed by a dash and a numerical value (example: DPYC-2.5).

For core types D and T, the numerical designation indicates the *cross-sectional Area (mm²)* of the core wire(s) in the cable.

For core types M and TT, the numerical designation indicates the *number of core wires* in the cable.

1. Core Type

D: Double core power line

T: Triple core power line

M: Multi core

TT: Twisted pair communications
(1Q=quad cable)

2. Insulation Type

P: Ethylene Propylene Rubber

3. Sheath Type

Y: PVC (Vinyl)

4. Armor Type

C: Steel

5. Sheath Type

Y: Anticorrosive vinyl sheath

6. Shielding Type

SLA: All cores in one shield, plastic tape w/aluminum tape

-SLA: Individually shielded cores, plastic tape w/aluminum tape



DPYC



TPYC



MPYC-4



TTYCSLA-4

EX: ¹ ³ ⁴ ⁵ ⁶ **TTYCYSLA - 4**
 Designation type | # of twisted pairs

¹ ² ³ ⁴ **MPYC - 4**
 Designation type | # of cores

The following reference table lists gives the measurements of JIS cables commonly used with Furuno products:

Type	Area	Core Diameter	Cable Diameter	Type	Area	Core Diameter	Cable Diameter
DPYC-1.5	1.5mm ²	1.56mm	11.7mm	TTYCSLA-1	0.75mm ²	1.11mm	9.4mm
DPYC-2.5	2.5mm ²	2.01mm	12.8mm	TTYCSLA-1T	0.75mm ²	1.11mm	10.1mm
DPYC-4	4.0mm ²	2.55mm	13.9mm	TTYCSLA-1Q	0.75mm ²	1.11mm	10.8mm
DPYC-6	6.0mm ²	3.12mm	15.2mm	TTYCSLA-4	0.75mm ²	1.11mm	15.7mm
DPYC-10	10.0mm ²	4.05mm	17.1mm	TTYCY-1	0.75mm ²	1.11mm	11.0mm
DPYCY-1.5	1.5mm ²	1.56mm	13.7mm	TTYCY-1T	0.75mm ²	1.11mm	11.7mm
DPYCY-2.5	2.5mm ²	2.01mm	14.8mm	TTYCY-1Q	0.75mm ²	1.11mm	12.6mm
DPYCY-4	4.0mm ²	2.55mm	15.9mm	TTYCY-4	0.75mm ²	1.11mm	17.7mm
MPYC-2	1.0mm ²	1.29mm	10.0mm	TTYCY-4SLA	0.75mm ²	1.11mm	19.5mm
MPYC-4	1.0mm ²	1.29mm	11.2mm	TTYCYSLA-1	0.75mm ²	1.11mm	11.2mm
MPYC-7	1.0mm ²	1.29mm	13.2mm	TTYCYSLA-4	0.75mm ²	1.11mm	17.9mm
MPYC-12	1.0mm ²	1.29mm	16.8mm	TTPYCSLA-1	0.75mm ²	1.11mm	9.2mm
TPYC-1.5	1.5mm ²	1.56mm	12.5mm	TTPYCSLA-1T	0.75mm ²	1.11mm	9.8mm
TPYC-2.5	2.5mm ²	2.01mm	13.5mm	TTPYCSLA-1Q	0.75mm ²	1.11mm	10.5mm
TPYC-4	4.0mm ²	2.55mm	14.7mm	TTPYCSLA-4	0.75mm ²	1.11mm	15.3mm
TPYCY-1.5	1.5mm ²	1.56mm	14.5mm				
TPYCY-2.5	2.5mm ²	2.01mm	15.5mm				
TPYCY-4	4.0mm ²	2.55mm	16.9mm				

PACKING LIST

FSS-301

026Y-X-9851 -2 1/1

A-1

NAME	OUTLINE	DESCRIPTION/CODE No.	Q'TY
ユニット			
制御部 PROCESSOR UNIT		FSS-301 000-037-192-00	1
予備品			
予備品 SPARE PARTS		SP26-00301 001-080-860-00	1
工事材料			
INSTALLATION MATERIALS			
ケーブル組品MJ CABLE ASSY.		MJ-A3SPF0018-050ZC 001-597-190-00	1
工事材料 INSTALLATION MATERIALS		CP10-09701 001-538-140-00	1
図書			
ヒューズ交換要領 FUSE REPLACEMENT GUIDE		C12-01903-* 000-197-190-1*	1

(略図の寸法は、参考値です。DIMENSIONS IN DRAWING FOR REFERENCE ONLY.)

C2393-Z01-C

PACKING LIST

FSS-302-*

026Y-X-9852 -4 1/1

A-2

NAME	OUTLINE	DESCRIPTION/CODE No.	Q'TY
ユニット			
送受信部 TRANSCEIVER UNIT		FSS-302-* 000-037-196-00 **	1
予備品			
予備品 SPARE PARTS		SP02-05901 001-568-430-00	1
工事材料			
INSTALLATION MATERIALS			
LANケーブル(CAT5E) CABLE ASSEMBLY		DT105E350SLABVCV10T 000-195-119-12	1
ケーブル組品MJ CABLE ASSY.		MJ-A3SPF0018-050ZC 001-597-190-00	1
工事材料 INSTALLATION MATERIALS		CP02-09701 001-568-460-00	1
図書			
取扱説明書 OPERATOR'S MANUAL		OM*-23930-* 000-197-142-1* **	1
整備要領書 INSTALLATION MANUAL		IM*-23930-* 000-197-144-1* **	1

コード番号末尾の[*]**は、選択品の代表コードを表します。
CODE NUMBER ENDING WITH ** INDICATES THE CODE NUMBER OF REPRESENTATIVE MATERIAL.

(略図の寸法は、参考値です。DIMENSIONS IN DRAWING FOR REFERENCE ONLY.)

C2393-Z02-E

PACKING LIST

RCU-026/-HK

24AL-X-9881 -0 1/1

A-3

NAME	UNIT	OUTLINE	DESCRIPTION/CODE No.	Q'TY
ユニット トラックボール操作部			RCU-026/-HK 000-027-666-00 **	1
付属品 ACCESSORIES			FP24-00801 001-418-410-00	1
工事材料 ケーブル(のびむ)USB			TS-20-071-1 L=5000 000-176-700-11	1
工事材料 INSTALLATION MATERIALS			CP24-02301 001-418-400-00	1

コード番号末尾の[**]は、選択品の代表コードを表します。
CODE NUMBER ENDING WITH "**" INDICATES THE CODE NUMBER OF REPRESENTATIVE MATERIAL

型式/コード番号が2段の場合、下段より上段に代わる過渡期品であり、どちらが入っています。なお、品質は変わりません。
TWO TYPES AND CODES MAY BE LISTED FOR AN ITEM. THE LOWER PRODUCT MAY BE SHIPPED IN PLACE OF THE UPPER PRODUCT. QUALITY IS THE SAME.
(略図の寸法は、参考値です。 DIMENSIONS IN DRAWING FOR REFERENCE ONLY.)

CN
C4473-Z33-A

A-4

FURUNO

CODE NO.	TYPE	001-538-140-00	CP10-09701	100A-X-9402 -0	1/1
工事材料表 INSTALLATION MATERIALS					
番号 NO.	名称 NAME	略図 OUTLINE	型名/規格 DESCRIPTIONS	数量 Q'TY	用途/備考 REMARKS
1	ケーブル CABLE TIE		CY-160N CODE NO. 000-162-186-10	8	
2	六角穴付 HEX HEAD SLOT BOLT-B ワッシャー WASHER		MX220 SUS304 CODE NO. 000-162-948-10	4	

(略図の寸法は、参考値です。 DIMENSIONS IN DRAWING FOR REFERENCE ONLY.)

FURUNO ELECTRIC CO., LTD.

C1363-M01-A

CODE NO.	001-568-460-00	028Y-X-9401-0	1/1
TYPE	CP02-09701		

工事材料表

INSTALLATION MATERIALS

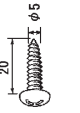
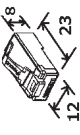
番号 NO.	名称 NAME	略図 OUTLINE	型名/規格 DESCRIPTIONS	数量 Q'TY	用途/備考 REMARKS
1	+15777777777777 1/2 SELF-TAPPING SCREW		5X20 SUS304 CODE NO. 000-162-608-10	4	
2	モジュール (モジュラ) MODULAR CONNECTOR		MPS588-C CODE NO. 000-166-044-10	2	

(略図の寸法は、参考値です。 DIMENSIONS IN DRAWING FOR REFERENCE ONLY.)

FURUNO ELECTRIC CO., LTD.

C2393-M01-A

CODE NO.	001-418-400-00	24AL-X-9409-0	1/1
TYPE	CP24-02301		

工事材料表

INSTALLATION MATERIALS

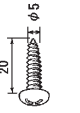
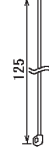
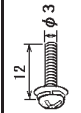
番号 NO.	名称 NAME	略図 OUTLINE	型名/規格 DESCRIPTIONS	数量 Q'TY	用途/備考 REMARKS
1	+15777777777777 1/2 SELF-TAPPING SCREW		5X20 SUS304 CODE NO. 000-162-608-10	2	
2	ケーブルツグ CABLE TIE		CV-125N CODE NO. 000-172-164-10	2	
3	+15777777777777 WASHER HEAD SCREW #8*		MX12 SUS304 CODE NO. 000-162-648-10	4	

型式/コード番号が2段の場合、下段より上段に代わる標準部品であり、どちらかが入っています。 なお、品質は変わりません。
TWO TYPES AND CODES MAY BE LISTED FOR AN ITEM. THE LOWER PRODUCT MAY BE SHIPPED IN PLACE OF THE UPPER PRODUCT.
QUALITY IS THE SAME.
(略図の寸法は、参考値です。 DIMENSIONS IN DRAWING FOR REFERENCE ONLY.)

FURUNO ELECTRIC CO., LTD.



C4473-M09-A

FURUNO

CODE NO.	1001-418-410-00	24AL-X-9512-0
TYPE	FP24-00801	1/1

付属品表

ACCESSORIES

番号 NO.	名称 NAME	略図 OUTLINE	型名/規格 DESCRIPTIONS	数量 QTY	用途/備考 REMARKS
1	卓上取付板 DESKTOP FIXING PLATE	100 	14-078-2311-0 CODE NO. 100-364-730-10	1	
2	USBシート USB SHEET	15 	24-014-1411-0 CODE NO. 100-372-000-10	1	
3	+F* 丸皿 WASHER HEAD SCREW *8*	8 	M3X8 SUS304 CODE NO. 000-162-649-10	2	

型式/コード番号が2取の場合、下取より上取に代わる運送部品であり、どちらが入っています。なお、品質は変わりません。

TWO TYPES AND CODES MAY BE LISTED FOR AN ITEM. THE LOWER PRODUCT MAY BE SHIPPED IN PLACE OF THE UPPER PRODUCT. QUALITY IS THE SAME. DIMENSIONS IN DRAWING FOR REFERENCE ONLY.)

(略図の寸法は、参考値です。)

FURUNO ELECTRIC CO., LTD.

ON

C4473-F10-A

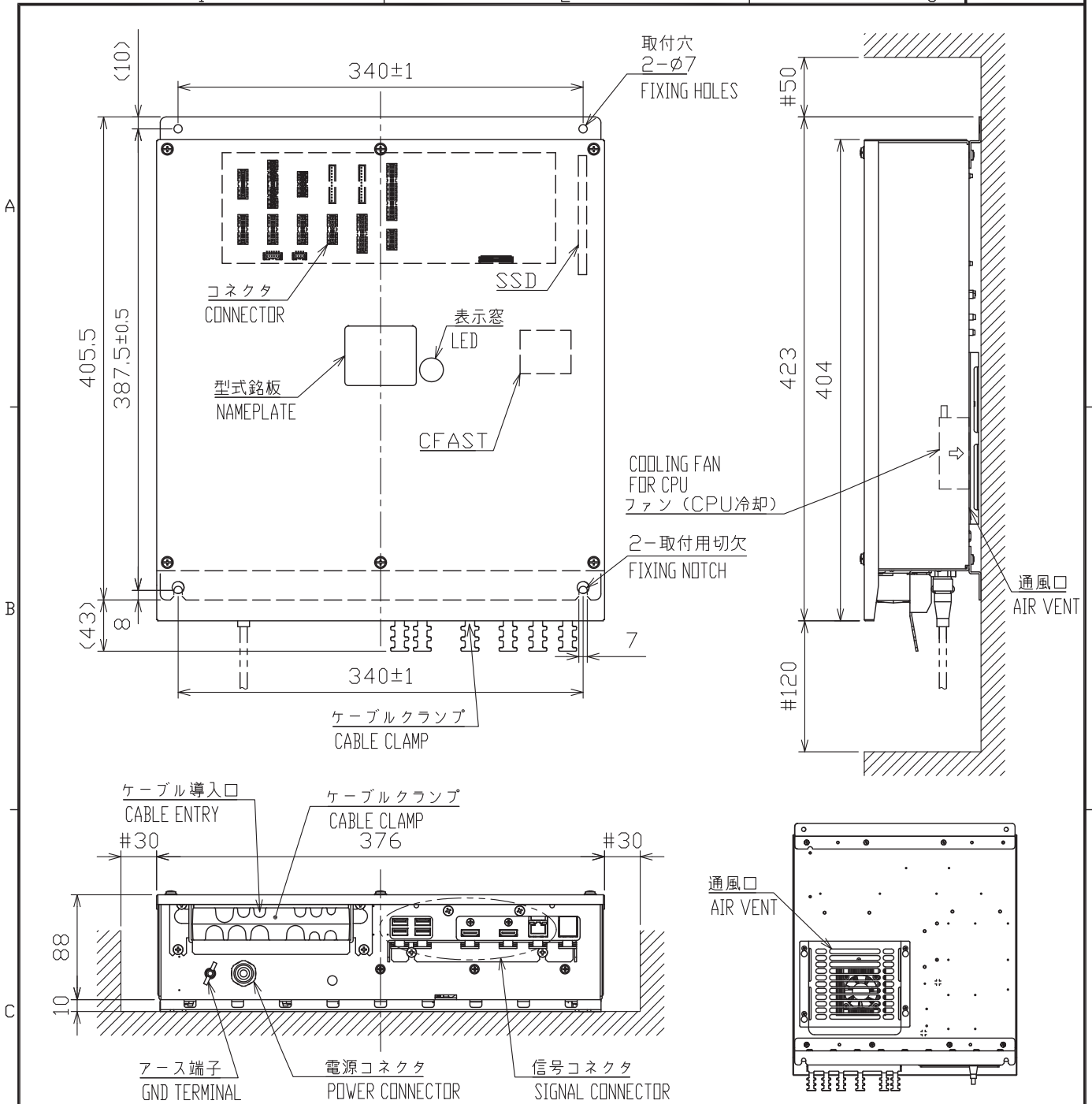

背面 (尺度:1/10)
REAR VIEW (SCALE: 1/10)

注 記

- 1) 指定外の寸法公差は表 1 による。
- 2) # 印寸法は最小サービス空間寸法とする。
- 3) 取付用ネジは M6 ボルトまたはコーチねじ呼び径 6 を使用のこと。

NOTE

1. TABLE 1 INDICATES TOLERANCE OF DIMENSIONS WHICH IS NOT SPECIFIED.
2. #: MINIMUM SERVICE CLEARANCE.
3. USE M6 BOLTS OR COARCH SCREWS φ6 FOR FIXING THE UNIT.

表 1 TABLE 1

寸法区分 (mm) DIMENSION	公差 (mm) TOLERANCE
L ≤ 50	±1.5
50 < L ≤ 100	±2.5
100 < L ≤ 500	±3

DRAWN 6/Aug/2019 T.YAMASAKI	TITLE FSS-301
CHECKED 6/Aug/2019 H.MAKI	名称 制御部 (壁掛・卓上装備)
APPROVED 8/Aug/2019 H.MAKI	外寸図
SCALE 1/5 MASS 7.6 ±10% kg	NAME PROCESSOR UNIT (BULKHEAD/TABLETOP MOUNT)
DWG. No. C2393-G01-A	REF. No. 02-179-301G-0

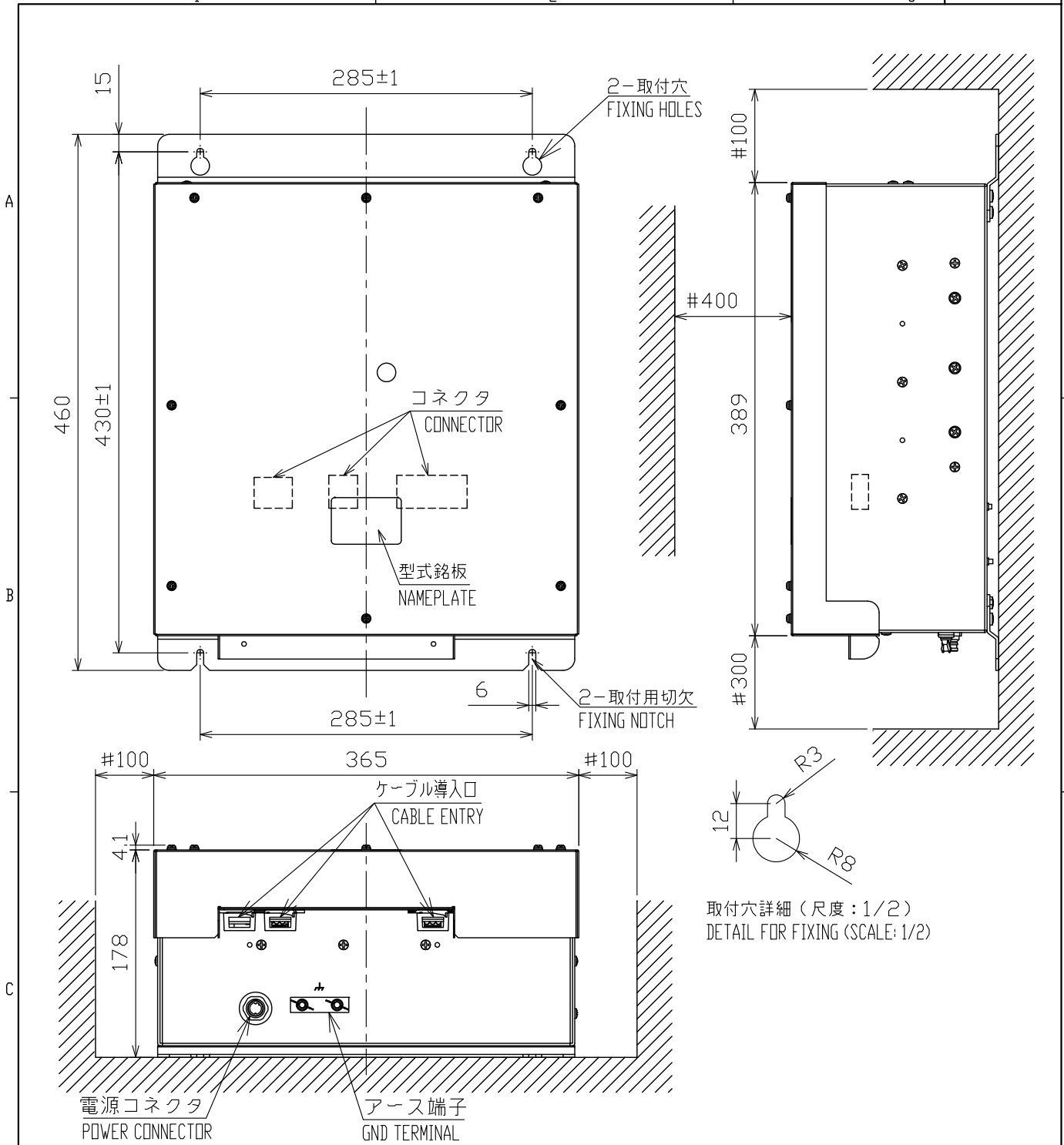

注記

- 1) 指定外の寸法公差は表1による。
- 2) 井印寸法は最小サービス空間寸法とする。
- 3) 取付ネジはトラスタッピンネジ呼び径5×20を使用のこと。

NOTE

1. TABLE 1 INDICATES TOLERANCE OF DIMENSIONS WHICH IS NOT SPECIFIED.
2. #: MINIMUM SERVICE CLEARANCE.
3. USE TAPPING SCREWS $\phi 5 \times 20$ FOR FIXING THE UNIT.

表1 TABLE 1

寸法区分 (mm) DIMENSION	公差 (mm) TOLERANCE
$L \leq 50$	± 1.5
$50 < L \leq 100$	± 2.5
$100 < L \leq 500$	± 3

DRAWN	7/Aug/2019 T.YAMASAKI	TITLE	FSS-302
CHECKED	7/Aug/2019 H.MAKI	名称	送受信部 (壁掛・卓上装備)
APPROVED	8/Aug/2019 H.MAKI	FSS-3BB	外寸図
SCALE	1/5	MASS	10 $\pm 10\%$ kg
DWG. No.	C2393-G02-A	REF. No.	02-179-100G-0
		NAME	TRANSCEIVER UNIT (BULKHEAD/TABLETOP MOUNT)
			OUTLINE DRAWING



表1 TABLE 1

寸法区分 (mm) DIMENSION	公差 (mm) TOLERANCE
L ≤ 50	±1.5
50 < L ≤ 100	±2.5
100 < L ≤ 500	±3

- 注記 1) 指定外の寸法公差は表1による。
 2) #印寸法は最小サービス空間寸法とする。
 3) 取付ネジはセムスネジ B M3×12を使用のこと。壁の厚さ(A)は最小2、最大4とする。それ以外はねじ長さをA+8±2とする。
- NOTE 1. TABLE 1 INDICATES TOLERANCE OF DIMENSIONS WHICH IS NOT SPECIFIED.
 2. # MINIMUM SERVICE CLEARANCE.
 3. USE SEMS B SCREWS M3x12 FOR BULKHEAD THICKNESS (A): 2≤A≤4. OR SCREW LENGTH: A+8±2.

DRAWN	14/Jun/2018	T.YAMASAKI	TITLE	RCU-026
CHECKED	14/Jun/2018	H.MAKI	名称	トラックボール操作部 (卓上装備)
APPROVED	14/Jun/2018	H.MAKI	外寸図	
SCALE	1/2	質量 1.4 kg FMD-3200 質量は5mケーブルを含む。 MASS INCLUDES 5m CABLE.	NAME	TRACKBALL CONTROL UNIT (TABLETOP MOUNT)
DWG.No.	C4473-G05-C	REF.No.	24-014-150G-2	OUTLINE DRAWING

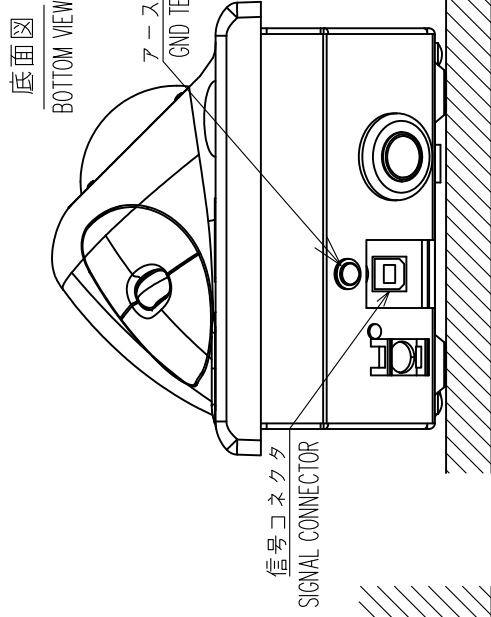
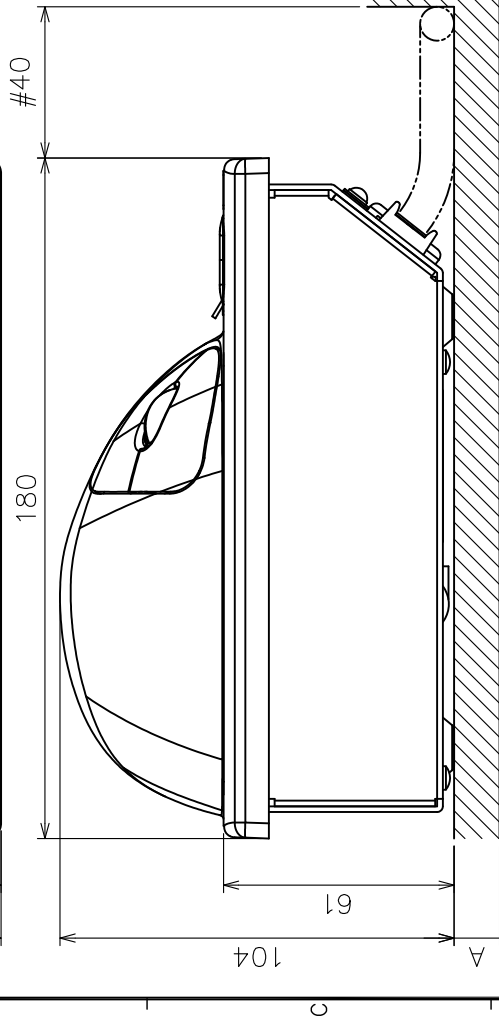
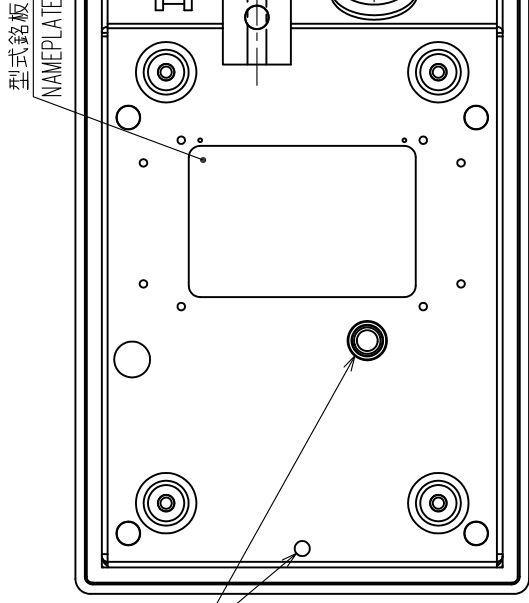
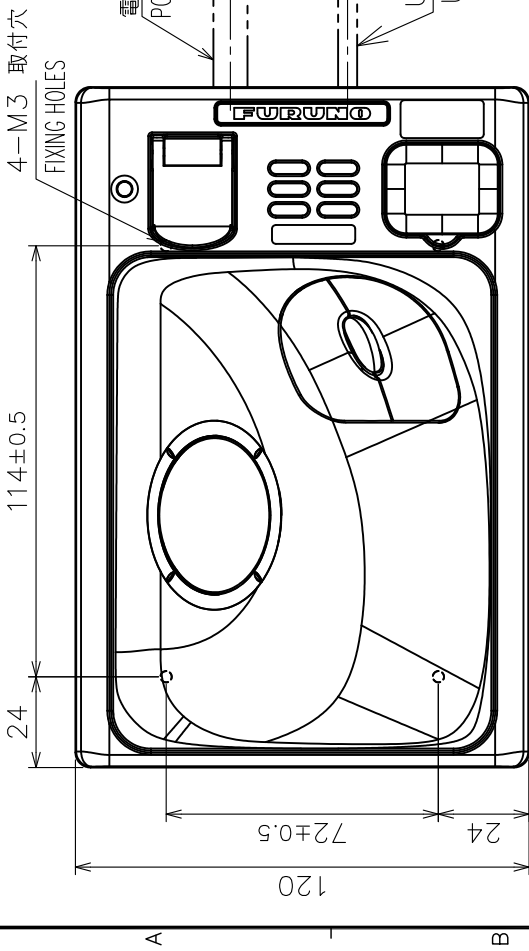
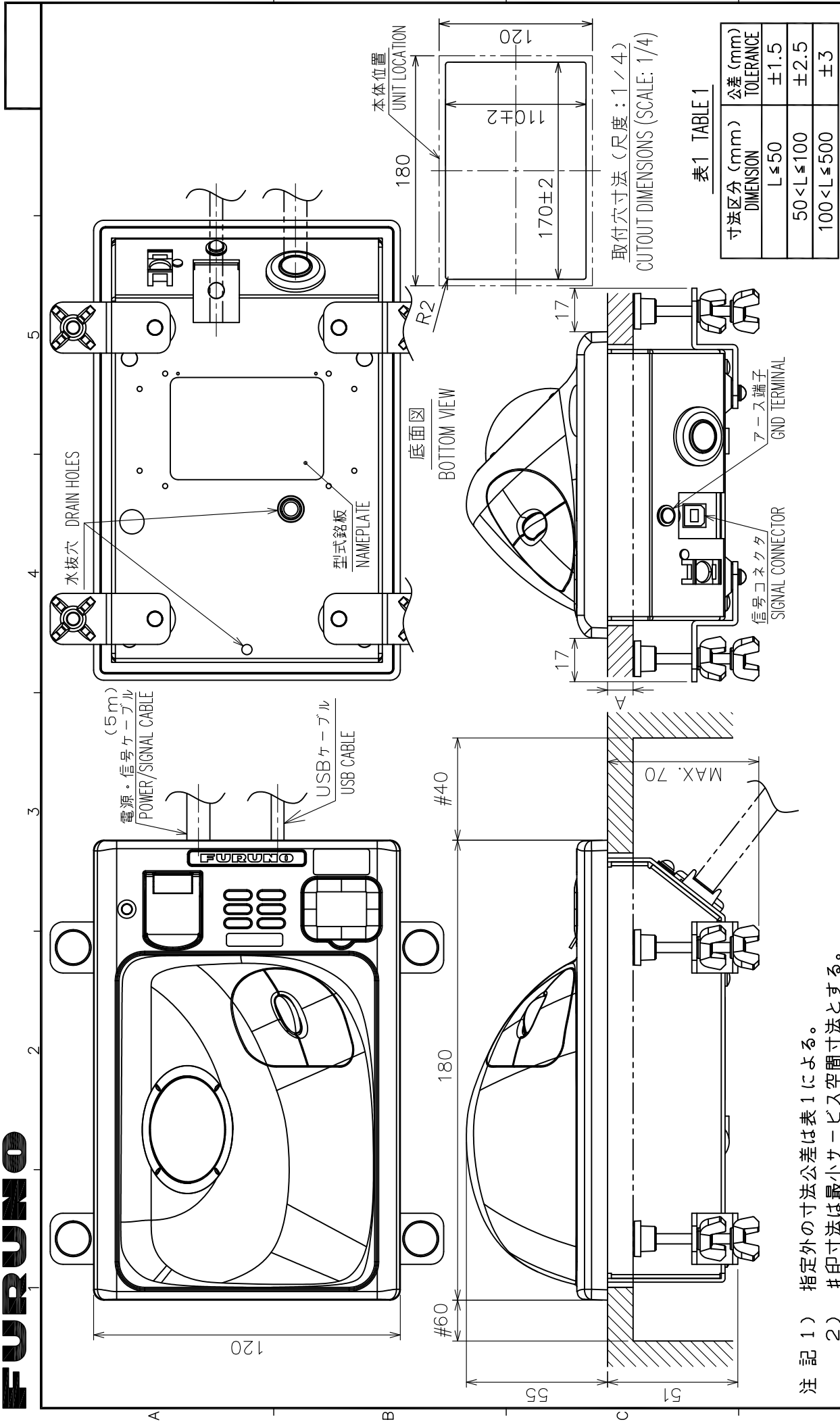

- 注記 1) 指定外の寸法公差は表1による。
 2) #印寸法は最小サージス空間寸法とする。
 3) 壁の厚さ(A)は最小10mm、最大20mmとする。
- NOTE 1. TABLE 1 INDICATES TOLERANCE OF DIMENSIONS WHICH IS NOT SPECIFIED.
 2. #: MINIMUM SERVICE CLEARANCE.
 3. BULKHEAD THICKNESS (A): 10 ≤ A ≤ 20.

DRAWN	14/Jun/2018	T.YAMASAKI	TITLE	RCU-026
CHECKED	14/Jun/2018	H.MAKI	名称	トラックボール操作部 (埋込装備)
APPROVED	14/Jun/2018	H.MAKI	FMD-3200	外寸図
SCALE	1/2	1MSS ±10% 質量は5mケーブルを含む。 MASS INCLUDES 5m CABLE.	NAME	TRACKBALL CONTROL UNIT (FLUSH MOUNT)
DWG.No.	C4473-G06-C	REF.No.	24-014-160G-2	OUTLINE DRAWING

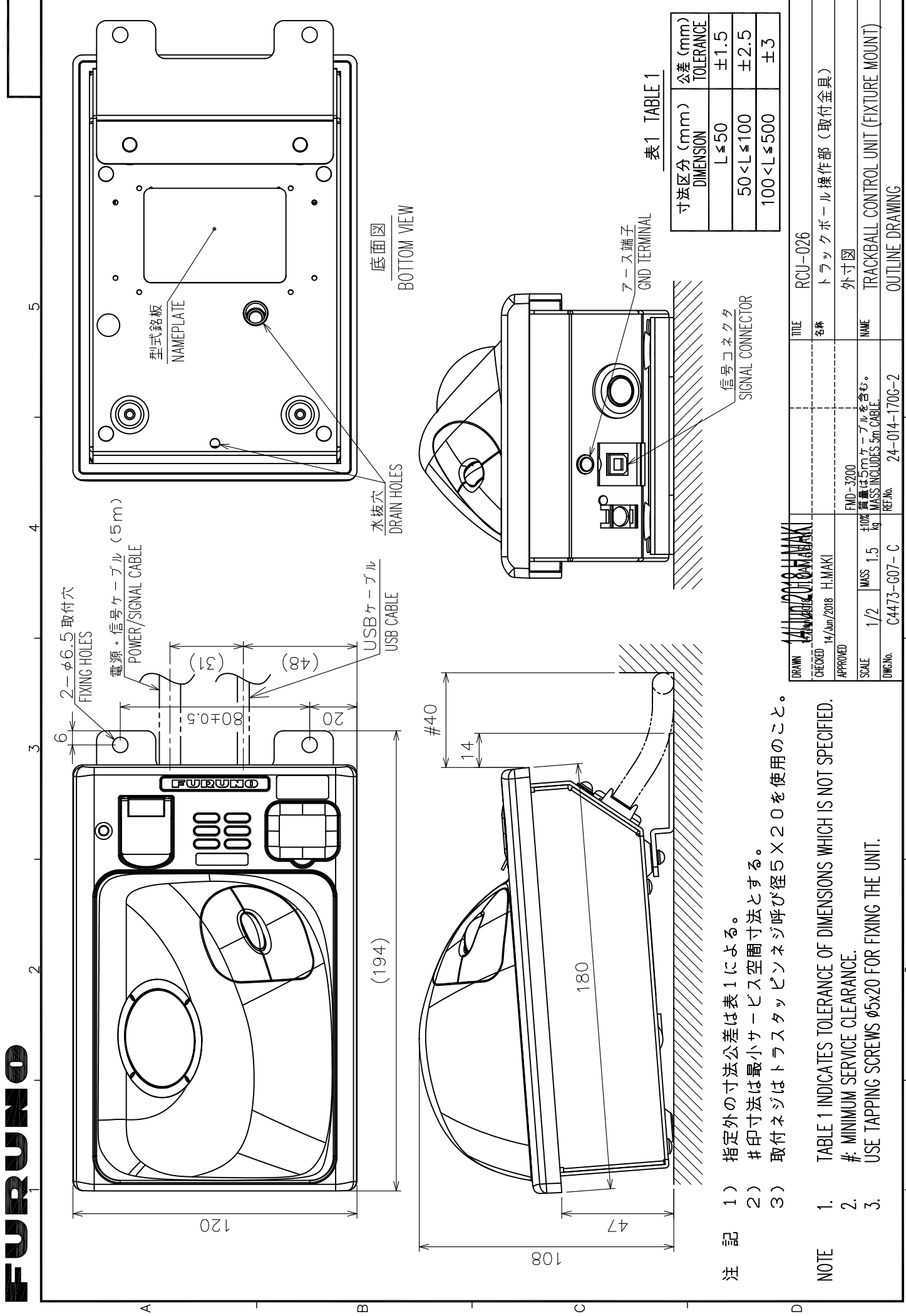

- 注記
- 1) 指定外の寸法公差は表1による。
 - 2) #印寸法は最小サービスクリアランスとする。
 - 3) 取付ネジはトラスタスピネジ呼び径5×20を使用のこと。
- NOTE
1. TABLE 1 INDICATES TOLERANCE OF DIMENSIONS WHICH IS NOT SPECIFIED.
 2. #: MINIMUM SERVICE CLEARANCE.
 3. USE TAPPING SCREWS φ5x20 FOR FIXING THE UNIT.

表1 TABLE 1

寸法区分(mm) DIMENSION	公差(mm) TOLERANCE
0 < L ≤ 50	±1.5
50 < L ≤ 100	±2.5
100 < L ≤ 500	±3

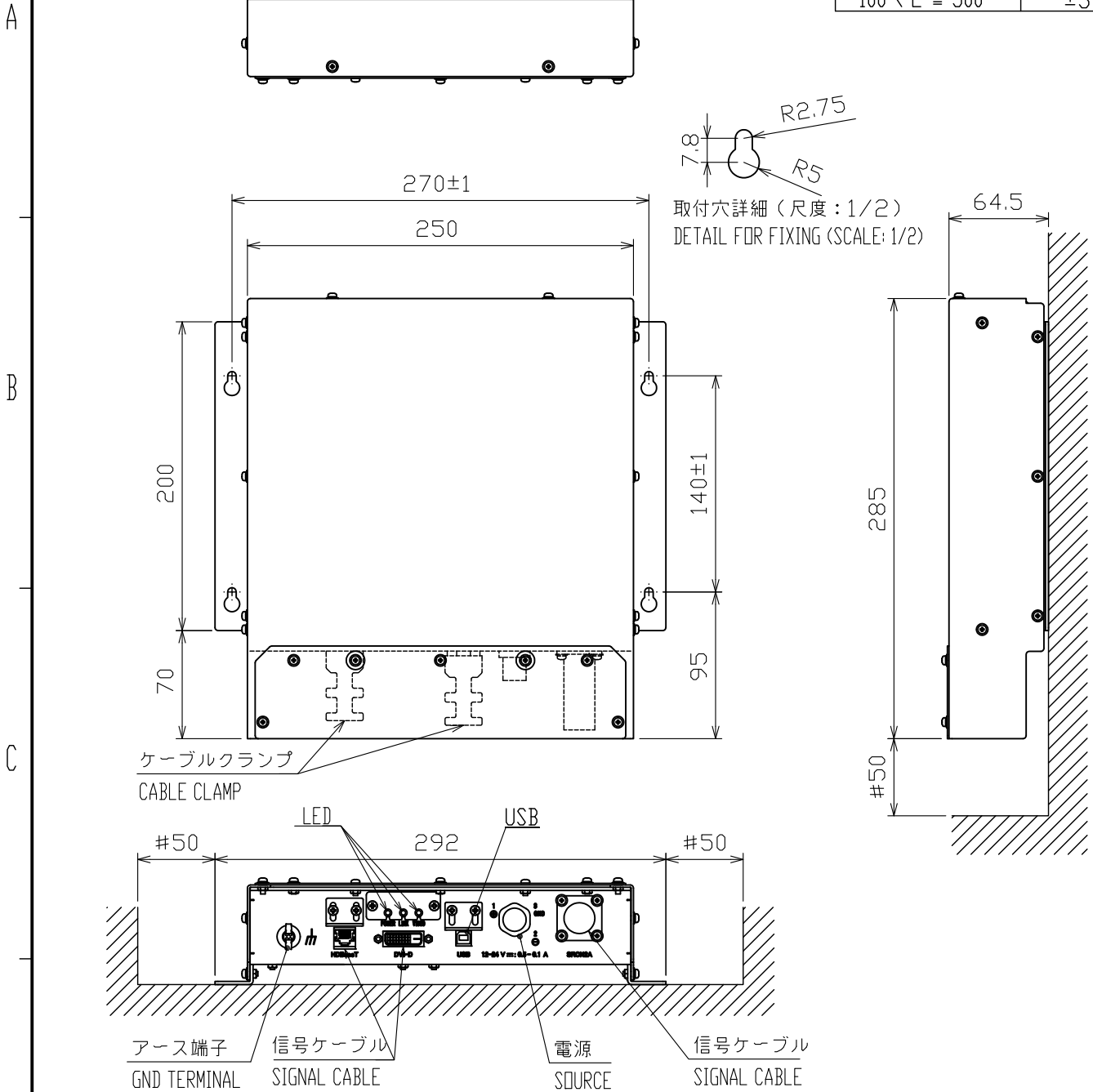

注記

1) 指定なき寸法公差は表1による。

NOTE

1. TABLE 1 INDICATES TOLERANCE OF DIMENSIONS WHICH IS NOT SPECIFIED.

DRAWN 9/Oct/2019 T.YAMASAKI		TITLE TM000-FDX06 TX
CHECKED 9/Oct/2019 H.MAKI		名称 送信機 (壁掛・卓上装備)
APPROVED 9/Oct/2019 H.MAKI	FCV-T900 FAR-15x3	外寸図
SCALE 1/4	MASS 1.4 ±10% kg	NAME TRANSMITTER UNIT (BULKHEAD/TABLETOP MOUNT)
DWG. No. C3638-G03-A	REF. No. PTM000-FDX06A-13	OUTLINE DRAWING

表1 TABLE 1

寸法区分(mm) DIMENSION	公差(mm) TOLERANCE
0 < L ≤ 50	±1.5
50 < L ≤ 100	±2.5
100 < L ≤ 500	±3

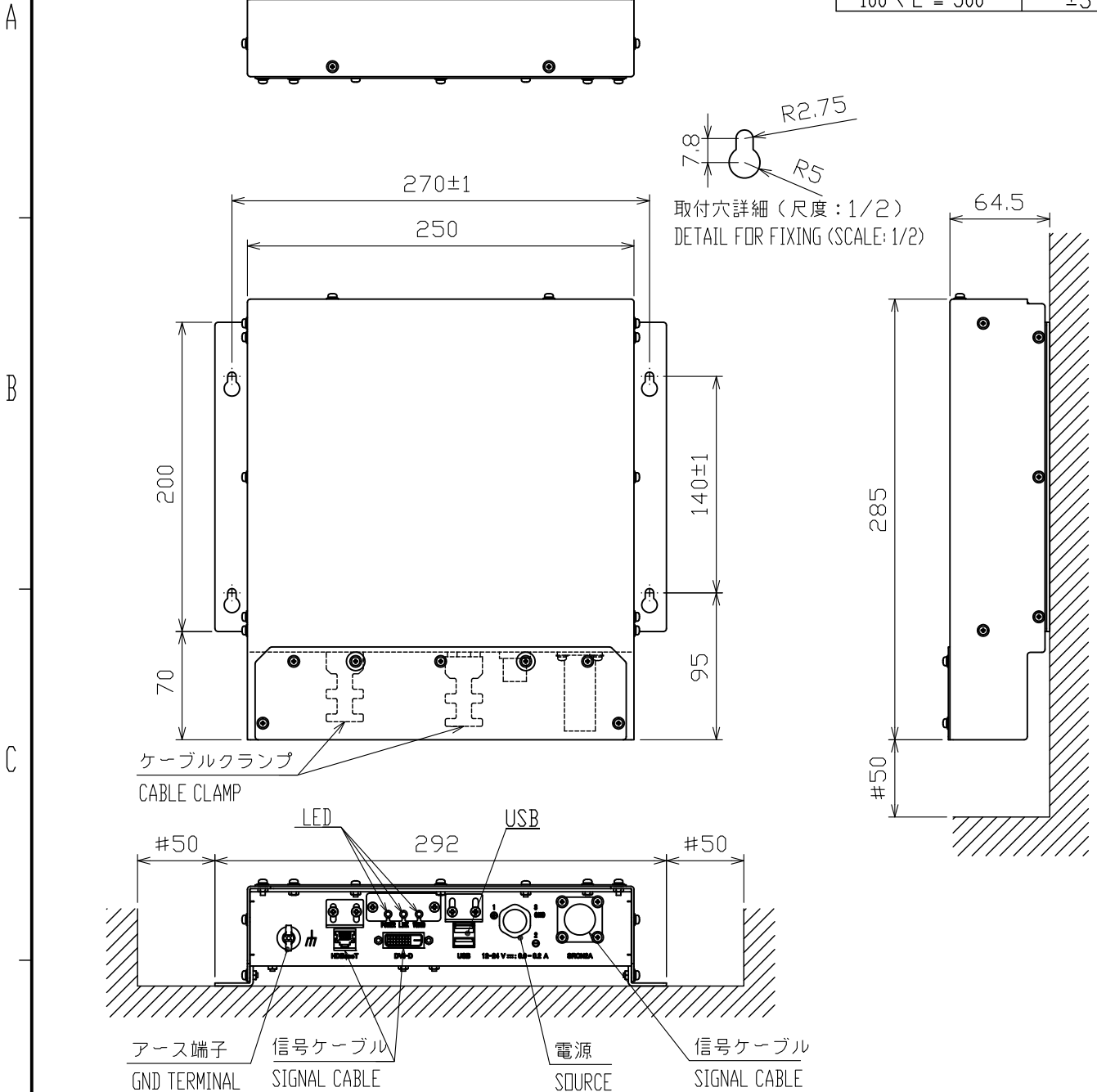

注記

1) 指定なき寸法公差は表1による。

NOTE

1. TABLE 1 INDICATES TOLERANCE OF DIMENSIONS WHICH IS NOT SPECIFIED.

DRAWN	9/Oct/2019 T.YAMASAKI		TITLE	TM000-FDX06 RX
CHECKED	9/Oct/2019 H.MAKI		名称	受信機 (壁掛・卓上装備)
APPROVED	9/Oct/2019 H.MAKI	FCV-T900 FAR-15x3		外寸図
SCALE	1/4	MASS 1.4 ±10% kg	NAME	RECEIVER UNIT (BULKHEAD/TABLETOP MOUNT)
DWG. No.	C3638-G04-A	REF. No.	PTM000-FDX06A-13	OUTLINE DRAWING



表1 (Table1)

寸法区分 (mm) Dimension	公差 (mm) Tolerance
L ≤ 50	±1.5
50 < L ≤ 100	±2.5
100 < L ≤ 500	±3

品目表 PRINCIPAL ITEMS	
船首から FROM BOW	m
キールから FROM KEEL	mm
突出量H	mm
取付状態 FIXING CONDITION	走行時水平 HORIZONTAL AT RUNNING
保護タンク PROTECTION TANK	

注記

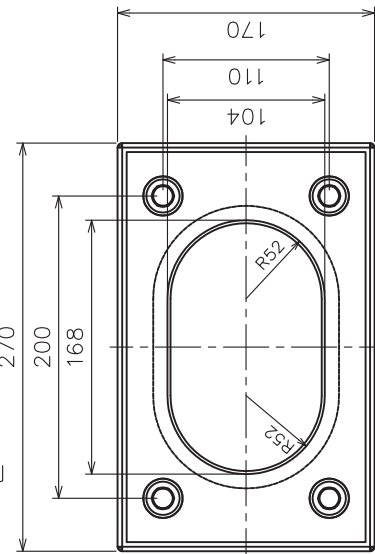
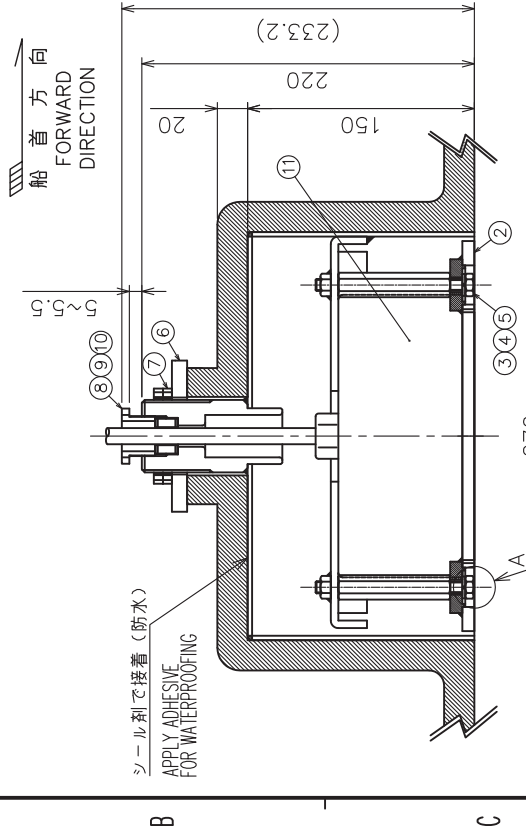
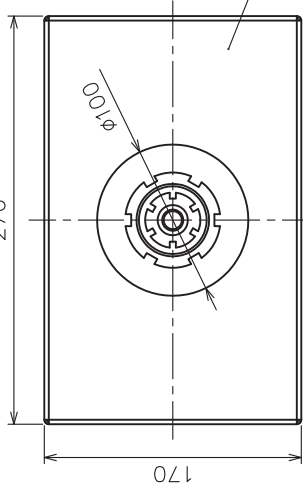
- 1) 指定外の寸法公差は、表1の通りです。
- 2) 塗装の際、送受波器面を塗装しない様に注意してください。
- 3) 送受波器取付け後、A部の隙間をシリコン等で埋めてください。
- 4) ボルト類には焼き付き防止グリスを塗布してください。

NOTE

1. TABLE 1 INDICATES TOLERANCE OF DIMENSIONS WHICH IS NOT SPECIFIED.
2. DO NOT PAINT TRANSDUCER FACE.
3. FILL THE GAP OF 'A' WITH SILICONE SEALANT.
4. APPLY BURN PREVENTION GREASE TO THREAD OF BOLTS.

送受波器 ITEM	品名 NAME	材質 MATERIAL	数量 QTY	図番 DWG. No.	備考 REMARKS
11	送受波器 TRANSDUCER		1	CM265LH/265LM/275LHW	選択 SELECT
10	ガスケット GASKET	CRJ1	1	JISF8801A20A	
9	塵金 WASHER	C3604	2	JISF8801A20A	
8	締付ナット NUT	C3604	1	JISF8801A20A	
7	ナット NUT	C3604	2	JISF8801-A35	G1 1/2
6	接合用スペーサ SPACER	SUS304	1	02-171-6104	
5	六角スペーサ HEX SPACER	SUS304	4	02-171-6103	
4	コイルバネ SPRING	SUS316L	4	M8	
3	コイルバネ SPRING	SUS316L	4	M8X20	
2	六角ボルト HEX-BOLT	SUS304	1	02-171-6102	
1	タンク本体 TANK	SUS304	1	02-171-6101	

DRAWN	2/4/2015	I. YAMASAKI
CHECKED	2/4/2015	H. MAKI
APPROVED	5/6/2015	H. MAKI
SCALE	1/5	質量は送受波器を含まず MASS DOES NOT INCLUDE TRANSDUCER.
DWG. No.	C2001-140-A	REF. No. 02-171-6100-0

品名 NAME	送受波器タンク
図番 DWG. No.	T-711F
数量 QTY	1
材質 MATERIAL	送受波器タンク
備考 REMARKS	送受波器タンク 送受波器タンク TRANSDUCER TANK TRANSDUCER TANK

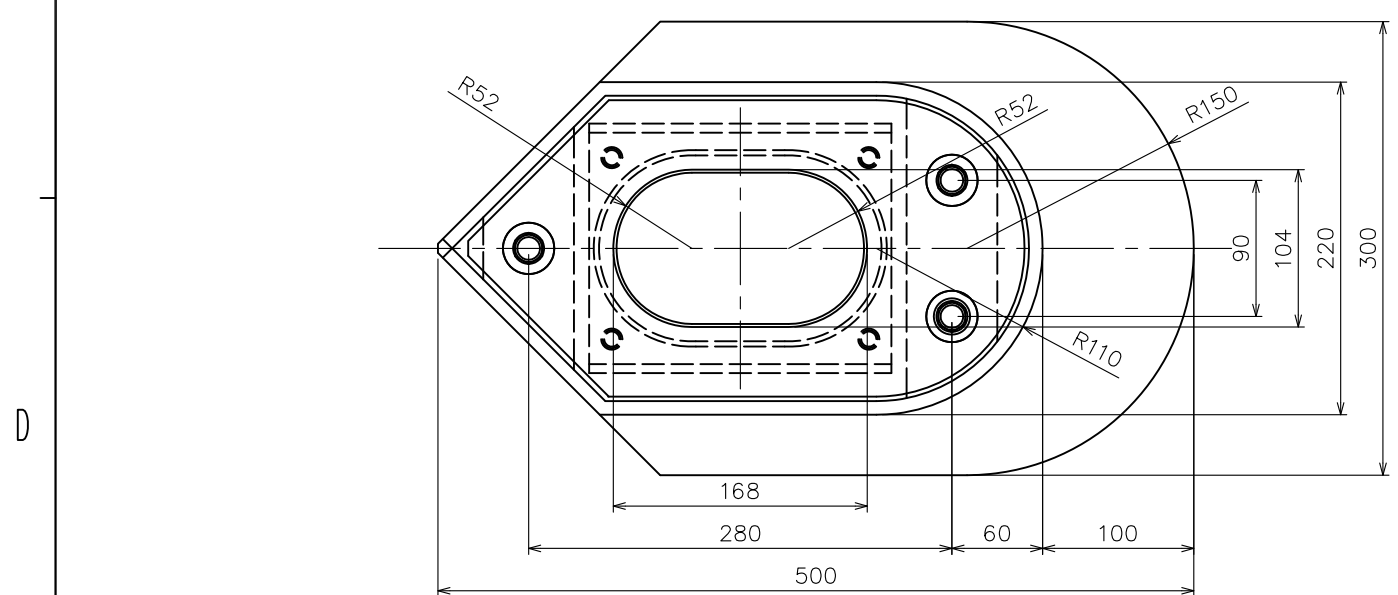
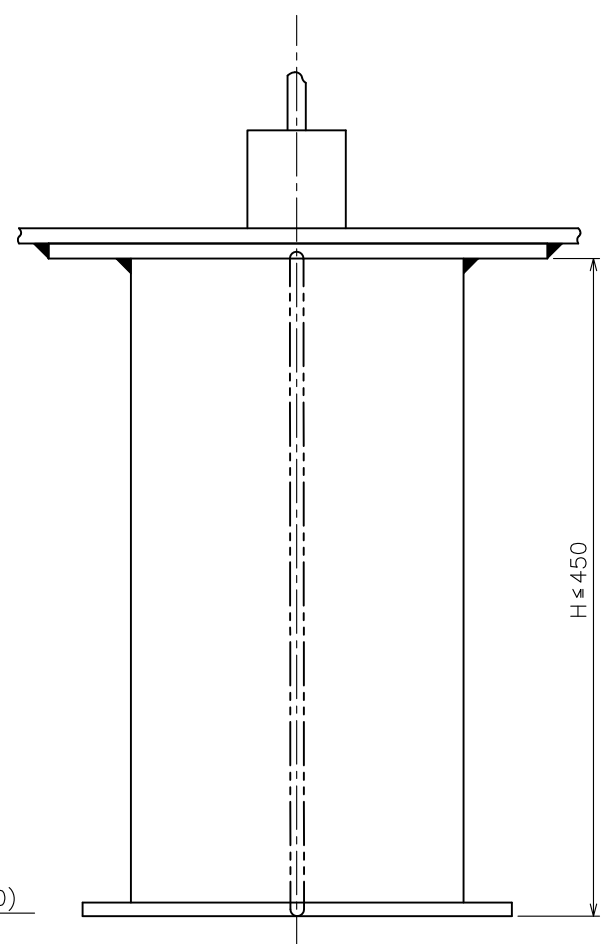
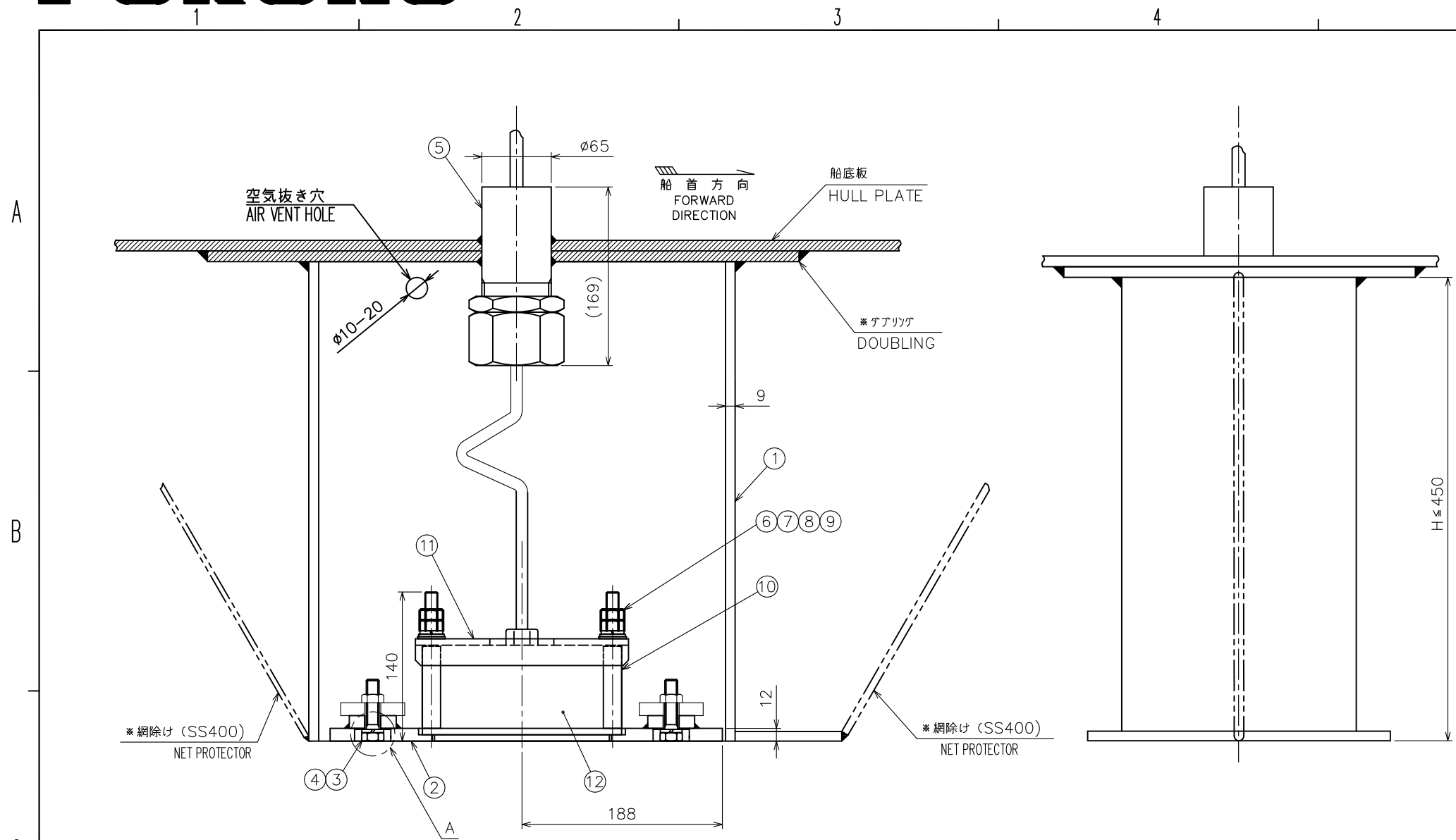

注記

- * : 造船所手配
- 送受波器ケースは「船底」にあわせて切断してください。
- 切断・溶接の際は、歪み防止のため送受波器を取り外した状態で「フランジ」を必ず取り付けおいてください。
- 電線貫通金物を溶接する際は、パッキンは取り外して行ってください。
- 船尾側上端に空気抜き用穴（φ10～φ20程度）をあけて下さい。
- 電線貫通金物はフレーム等の邪魔にならない所で送受波器に当たらず、キャップナットが容易に締め付けられる位置に取り付けてください。
- 網除け、保護タンクは必要に応じて造船所にて製作してください。
- 塗装の際、送受波器面を塗装しない様に注意してください。
- 送受波器取付け後、A部の隙間をシリコン等で埋めてください。
- 指定外の寸法公差は、表1の通りです。
- ボルト類には焼き付き防止グリス（モリソーラ1910等）を塗布してください。

NOTE

- * : SHIPYARD SUPPLY
- CUT CASING FOR SHIP'S HULL
- TO AVOID DISTORTION BY HEAT, PUT "FIXING FLANGE" W/O TRANSDUCER ONTO CASING WHILE CUTTING AND/OR WELDING.
- REMOVE THE GASKET FROM THRU-HULL PIPE BEFORE WELDING.
- MAKE A HOLE OF 10-20mm IN DIA. ON STERN SIDE OF THE TANK TO ALLOW AIR TO ESCAPE FROM TANK.
- ALLOW ENOUGH CLEARANCE AROUND THRU-HULL PIPE FOR EASY TIGHTENING AND SERVICING.
- IF NECESSARY, PROVIDE NET PROTECTOR AND PROTECTION TANK BY SHIPYARD.
- DO NOT PAINT THE TRANSDUCER FACE.
- FILL THE GAP OF 'A' WITH SILICONE SEALANT.
- TABLE 1 INDICATES TOLERANCE OF DIMENSIONS WHICH IS NOT SPECIFIED.
- APPLY BURN PREVENTION GREASE TO BOLTS.

表1 (Table1)

寸法区分 (mm) Dimension	公差 (mm) Tolerance
L ≦ 50	±1.5
50 < L ≦ 100	±2.5
100 < L ≦ 500	±3

品番 ITEM	品名 NAME	材質 MATERIAL	数量 Q'TY	図番 DWG.NO.	摘要 REMARKS
12	送受波器 TRANSDUCER		1	CM265LH	質量に含まず。 NOT INCLUDED IN MASS
11	押え板 FIXING PLATE	SS400	1	02-163-6004	
10	スペーサル=77 SPACER	SGP	4	02-163-6003	
9	平座金 FLAT WASHER	POM	4	T-201-11	呼び12 MONI12
8	平座金 FLAT WASHER	SUS316L	4		M12
7	バネ座金 SPRING WASHER	SUS316L	4		M12
6	六角ナット HEX. NUT	SUS316L	8		M12
5	電線貫通金物 THRU-HULL PIPE		1	TFB-7000(1)	1HOLE 1穴
4	バネ座金 SPRING WASHER	SUS316L	3		M12
3	六角ボルト HEX. BOLT	SUS316L	3		M12x50
2	フランジ FIXING FLANGE	SS400	1	02-163-6002	
1	送受波器ケース CASING	SS400	1	02-163-6001	

DRAWN	15/Feb/2013 I.YAMASAKI	TITLE	T-711
CHECKED	15/Feb/2013 H.MAKI	名称	送受波器タンク（鋼船）
APPROVED	15/Feb/2013 Y.NISHIYAMA	図番	送受波器装備図
SCALE	1/5 MASS 43 ±10% kg	NAME	TRANSDUCER TANK (STEEL HULL)
DWG. No.	C2001-T39-B	REF. No.	02-163-600G-1
		TRANSDUCER INSTALLATION	



表1 (Table1)

寸法区分 (mm) Dimension	公差 (mm) Tolerance
L ≤ 50	±1.5
50 < L ≤ 100	±2.5
100 < L ≤ 500	±3
500 < L ≤ 1000	±4

- NOTE
- TABLE 1 INDICATES TOLERANCE OF DIMENSIONS WHICH IS NOT SPECIFIED.
 - ※: SHIPYARD SUPPLY
 - CUT CASING FOR θ (RISING ANGLE OF SHIP'S HULL).
 - TO AVOID DISTORTION BY HEAT. PUT "FIXING FLANGE" W/O TRANSDUCER ONTO CASING WHILE CUTTING AND/OR WELDING. WELDING SHOULD BE PREPARED BY SHIPYARD.
 - REMOVE GASKET FROM THE THRU-HULL PIPE BEFORE WELDING.
 - MAKE SURE THE FORE-AFT DIRECTION OF THE CASING BEFORE INSTALLATION.
 - MAKE A HOLE OF 10 TO 20mm IN DIAMETER ON STERN SIDE FOR ESCAPING AIR FROM THE TANK.
 - KEEP ENOUGH CLEARANCE AROUND THRU-HULL PIPE FOR EASY TIGHTENING AND SERVICING.
 - IF NECESSARY, PROVIDE NET PROTECTOR AND PROTECTION TANK BY SHIPYARD.
 - AFTER THE INSTALLATION, REMOVE THE ANTICORROSIVE PAINT FROM THE CASING AND THEN PAINT ACCORDING TO SHIPYARD INSTRUCTIONS.
 - DO NOT PAINT THE TRANSDUCER FACE.
 - FILL THE GAP OF "A" WITH SILICONE SEALANT.
 - APPLY BURN PREVENTION GREASE TO THREAD OF BOLTS.

17	上板 TOP PLATE	SS400	1	02-171-6051	
16	平座金 FLAT WASHER	SUS316L	4		M20 造船所手配 SHIPYARD SUPPLY
15	バネ座金 SPRING WASHER	SUS316L	4		M20 造船所手配 SHIPYARD SUPPLY
14	六角ナット HEX. NUT	SUS316L	8		M20 造船所手配 SHIPYARD SUPPLY
13	六角ボルト HEX. BOLT	SUS316L	4		M20 造船所手配 SHIPYARD SUPPLY
12	送受波器 TRANSDUCER		1	CM599LH/LHW/LM PM111LH/LM, PM411LWM	選択 SELECT
11	押え板 FIXING PLATE	SS400	1	02-171-6004	
10	スペーサ L=111 SPACER	SGP	4	02-171-6003	
9	平座金 FLAT WASHER	POM	4	T-201-11	呼び12 MONI12
8	平座金 FLAT WASHER	SUS316L	4		M12
7	バネ座金 SPRING WASHER	SUS316L	4		M12
6	六角ナット HEX. NUT	SUS316L	8		M12
5	電線貫通金物 THRU-HULL PIPE		1	TRB-1100(1)	1穴 1 HOLE
4	バネ座金 SPRING WASHER	SUS316L	8		M12
3	六角ボルト HEX. BOLT	SUS316L	8		M12x50
2	フランジ FIXING FLANGE	SS400	1	02-171-6002	
1	送受波器ケース CASING	SS400	1	02-171-6001	
品番 ITEM	品名 NAME	材質 MATERIAL	数量 QTY	図番 DWG. No.	摘要 REMARKS

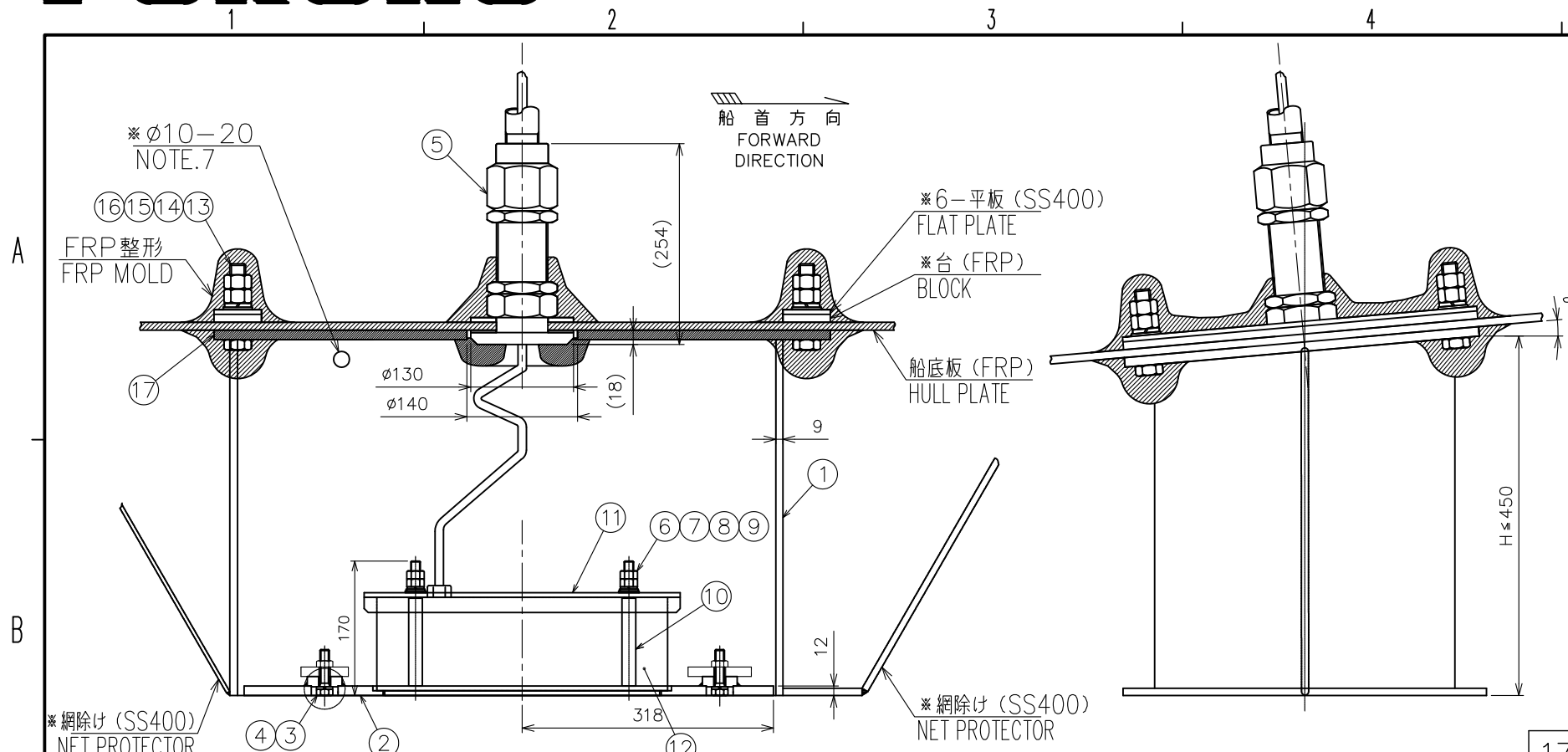
注記

- 指定外の寸法公差は、表1の通りです。
- ※: 造船所手配
- 送受波器ケースはθ (船底傾斜角) にあわせて切断ください。
- 切断・溶接の際は、歪み防止のため送受波器を取り外した状態で“フランジ”を必ず取り付けておいてください。溶接方法は造船所一任。
- 電線貫通金物を溶接する際は、パッキンは取り外して行ってください。
- 送受波器ケース取付の際には船首、船尾の確認をしてください。
- 船尾側上端に空気抜き用穴 (φ10~φ20程度) をあけてください。
- 電線貫通金物はフレーム等の邪魔にならない所で送受波器に当たらず、キャップナットが容易に締め付けられる位置に取り付けてください。
- 網除け、保護タンクは必要に応じて造船所にて製作してください。
- 装備後はサビ止め塗装をはがした後正規の塗装をおこなってください。
- 塗装の際、送受波器面を塗装しない様に注意してください。
- 送受波器取付け後、A部の隙間をシリコン等で埋めてください。
- ボルト類には焼き付き防止グリスを塗布してください。

DRAWN	21/Feb/2020 T.YAMASAKI	TITLE	T-712F	
CHECKED	21/Feb/2020 H.MAKI	名称	送受波器タンク	
APPROVED	21/Feb/2020 H.MAKI		送受波器装備図	
SCALE	1/8	質量	103 ±10% kg	
DWG. No.	C2001-T42-B	質量は送受波器を含まず。 MASS DOES NOT INCLUDES TRANSDUCER.	NAME	TRANSDUCER TANK
		REF. No.	02-171-605G-0	TRANSDUCER INSTALLATION

	D-11
装備法分類番号 INSTALLATION METHOD	T- 712

表1 (Table1)

寸法区分 (mm) Dimension	公差 (mm) Tolerance
L ≤ 50	±1.5
50 < L ≤ 100	±2.5
100 < L ≤ 500	±3
500 < L ≤ 1000	±4

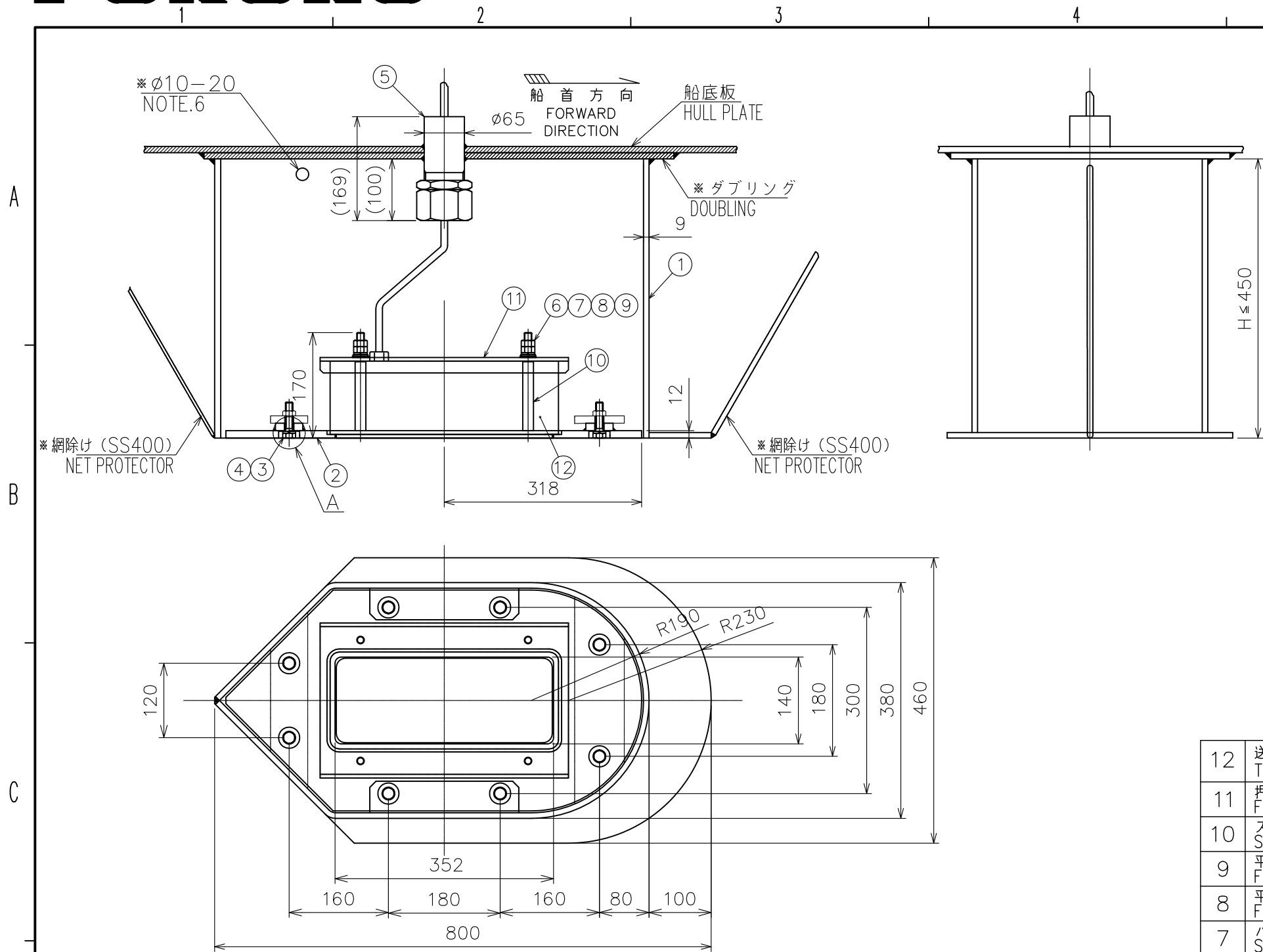

NOTE

- TABLE 1 INDICATES TOLERANCE OF DIMENSIONS WHICH IS NOT SPECIFIED.
- *: SHIPYARD SUPPLY.
- CUT CASING AS RISING ANGLE OF SHIP'S HULL.
- TO AVOID DISTORTION BY HEAT. PUT "FIXING FLANGE" WITHOUT TRANSDUCER ONTO CASING WHILE CUTTING AND/OR WELDING. WELDING SHOULD BE PREPARED BY SHIPYARD.
- REMOVE GASKET FROM THE THRU-HULL PIPE BEFORE WELDING.
- MAKE A HOLE OF 10 TO 20MM IN DIAMETER ON STERN SIDE FOR ESCAPING AIR FROM TANK.
- KEEP ENOUGH CLEARANCE AROUND THRU-HULL PIPE FOR EASY TIGHTENING AND SERVICING.
- IF NECESSARY, PROVIDE NET PROTECTOR AND PROTECTION TANK BY SHIPYARD.
- DO NOT PAINT TRANSDUCER FACE.
- FILL THE GAP OF 'A' WITH SILICONE SEALANT.
- APPLY BURN PREVENTION GREASE TO THE THREAD OF BOLTS.

12	送波器 TRANSDUCER		1	CM599LH/LHW/LM PM111LH/LM, PM411LWM	選択 SELECT
11	押え板 FIXING PLATE	SS400	1	02-171-6004	
10	スペーサ L=111 SPACER	SGP	4	02-171-6003	
9	平座金 FLAT WASHER	POM	4	T-201-11	呼び12 MONI12
8	平座金 FLAT WASHER	SUS316L	4		M12
7	バネ座金 SPRING WASHER	SUS316L	4		M12
6	六角ナット HEX. NUT	SUS316L	8		M12
5	電線貫通金物 THRU-HULL PIPE		1	TFB-7000(1)	1穴 1 HOLE
4	バネ座金 SPRING WASHER	SUS316L	8		M12
3	六角ボルト HEX. BOLT	SUS316L	8		M12x50
2	フランジ FIXING FLANGE	SS400	1	02-171-6002	
1	送波器ケース CASING	SS400	1	02-171-6001	
品番 ITEM	品名 NAME	材質 MATERIAL	数量 QTY	図番 DWG. No.	摘要 REMARKS

注記

- 指定外の寸法公差は、表1の通りです。
- *: 造船所手配
- 送受波器ケースは、船底の傾きに合わせて切断してください。
- 切断・溶接の際は、歪み防止のため送受波器を取り外した状態で“フランジ”を必ず取り付けておいてください。溶接方法は造船所一任。
- 電線貫通金物は、パッキンを取り外して溶接してください。
- 船尾側上端に空気抜き用穴(φ10~φ20程度)をあけてください。
- 電線貫通金物はフレーム等の邪魔にならない所で、送受波器に当たらず、キャップナットが容易に締め付けられる位置に取り付けてください。
- 網除け・保護タンクは、必要に応じて造船所にて製作してください。
- 送受波器面は塗装しない様に注意してください。
- 送受波器取付け後、A部の隙間をシリコン等で埋めてください。
- 1) ボルト類には焼き付き防止グリスを塗布してください。

DRAWN	21/Feb/2020 T.YAMASAKI	TITLE	T-712	
CHECKED	21/Feb/2020 H.MAKI	名称	送受波器タンク	
APPROVED	21/Feb/2020 H.MAKI		送受波器装備図	
SCALE	1/8	質量は送受波器を含まず。 MASS DOES NOT INCLUDES TRANSDUCER.	NAME	TRANSDUCER TANK
DWG. No.	C2001-T41-B	REF. No.	02-171-600G-1	TRANSDUCER INSTALLATION

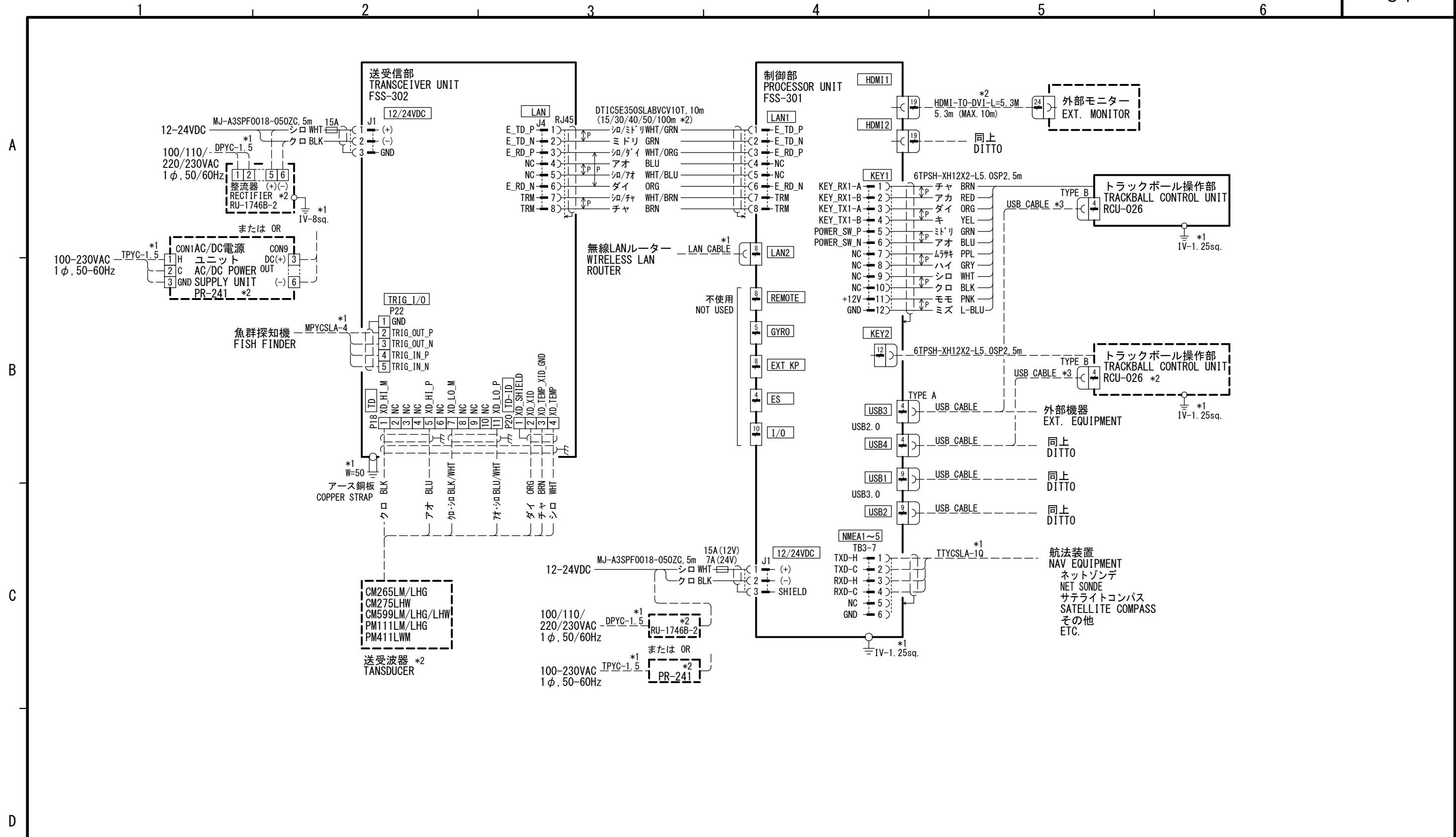

注記
 * 1) 造船所手配。
 * 2) オプション。
 * 3) 操作部上のUSBポートを使用するとき。

NOTE
 *1: SHIPYARD SUPPLY.
 *2: OPTION.
 *3: TO USE THE USB PORT ON CONTROL UNIT.

DRAWN 25/Aug/2021 T. YAMASAKI	TITLE FSS-3BB
CHECKED 25/Aug/2021 H. MAKI	名称 魚群探知機
APPROVED 2/Sep/2021 H. MAKI	相互結線図
SCALE MASS kg	NAME FISH FINDER
DWG. No. C2393-C01- D	REF. No. 02-179-2001-0
INTERCONNECTION DIAGRAM	

4

3

2

1

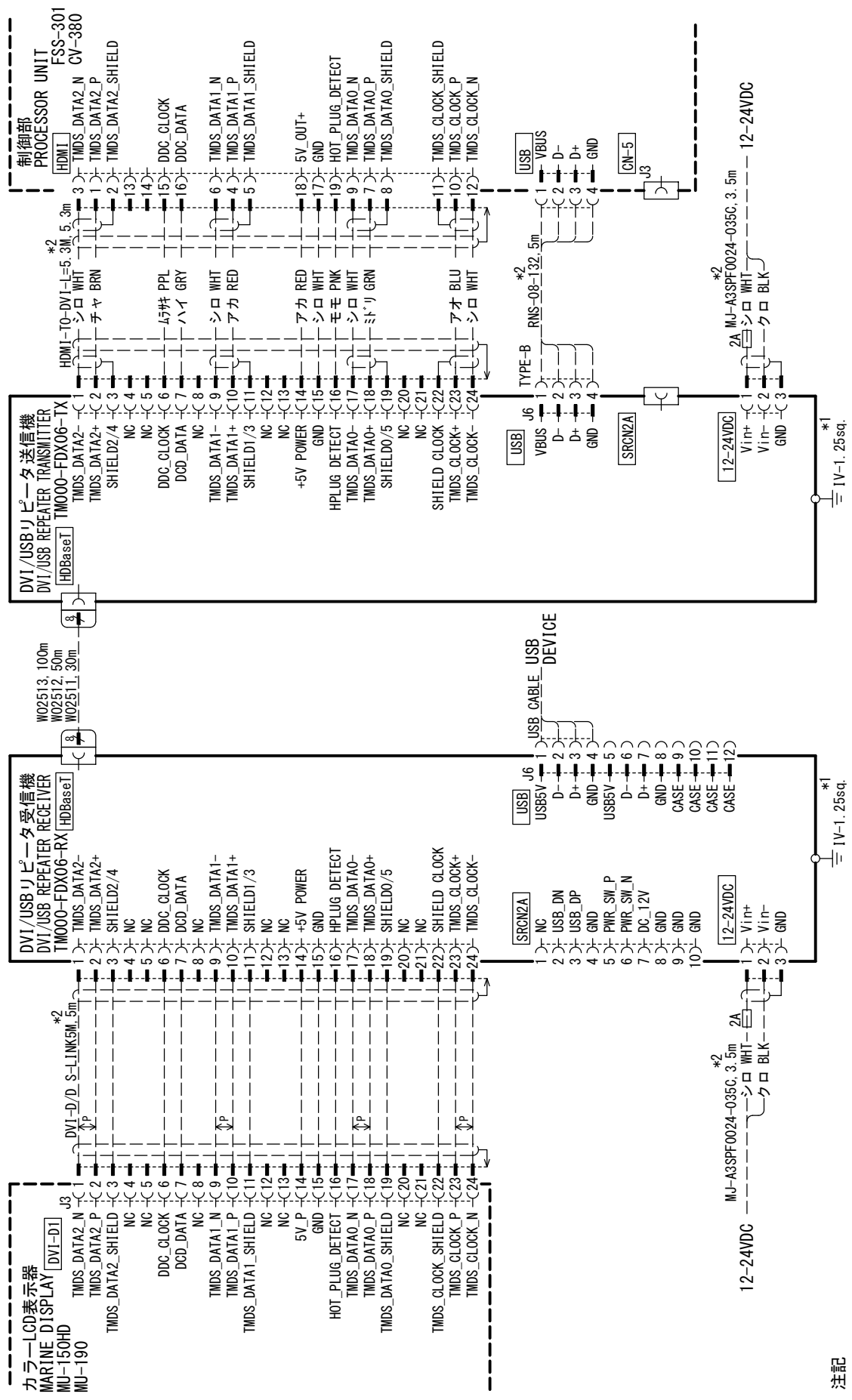

A

B

C

注記
 * 1) 造船所手配。
 * 2) オプション。

NOTE
 *1: SHIPYARD SUPPLY.
 *2: OPTION.

DRAWN	18/Feb/2020	T. YAMASAKI	TITLE	TM000-FDX06-TX/RX
CHECKED	18/Feb/2020	H. MAKI	名称	DVI/USBリピータ
APPROVED	18/Mar/2020	H. MAKI	相互接続図	
SCALE		1/25	NAME	DVI/USB REPEATER
DWG No.	C2393-002-A	kg	REF. No.	INTERCONNECTION DIAGRAM

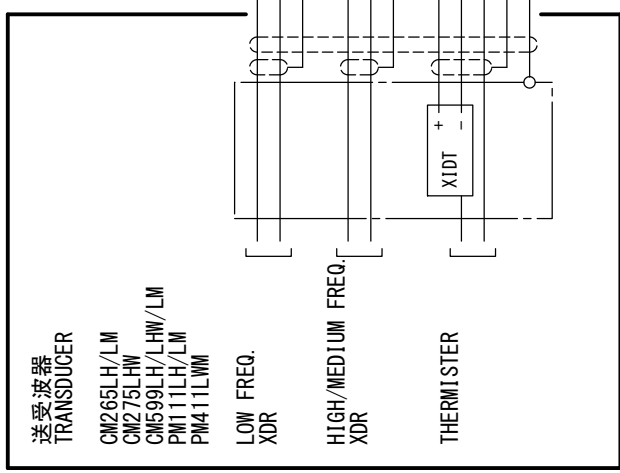

型式 MODEL	CM599LH/LHW/LM PM111LH/LM PM411LWM	CM265LH/LM CM275LHW
ケーブル長さ CABLE LENGTH	15 m	12 m

- XD_LO_P
- XD_LO_M
- XD_LO_SHIELD
- XD_HI_P
- XD_HI_M
- XD_HI_SHIELD
- XD_XID
- XD_TEMP/XID_GND
- XD_TEMP
- XD_SHIELD
- GND

DRAWN	21/Feb/2020 T. YAMASAKI	TITLE	CM265/275/599, PM111/411 SER.
CHECKED	21/Feb/2020 H. MAKI	名称	送受波器
APPROVED	3/Apr/2020 H. MAKI	相互結線図	
SCALE	MASS kg	NAME	TRANSDUCER
DWG. No.	C2003-C01-C	REF. No.	INTERCONNECTION DIAGRAM