

Installation Manual

DOPLER SPEED LOG

Model DS-85

SAFETY INSTRUCTIONS	i
SYSTEM CONFIGURATION	ii
EQUIPMENT LISTS	iii
1. MOUNTING	1-1
1.1 Display Unit.....	1-1
1.2 Distributor Unit	1-5
1.3 Transceiver Unit.....	1-6
1.4 Transducer.....	1-8
1.5 Option Unit.....	1-22
2. WIRING	2-1
2.1 Overview	2-1
2.2 Precautions for Cable Installation	2-2
2.3 Display Unit.....	2-2
2.4 Distributor Unit	2-5
2.5 Transceiver Unit.....	2-10
2.6 Junction Box (option)	2-12
2.7 Grounding	2-14
3. ADJUSTMENTS	3-1
3.1 [EQUIPMENT] sub menu	3-3
3.2 [I/O] sub menu	3-6
3.3 [SIMULATION] sub menu	3-7
3.4 [MAINTENANCE] sub menu	3-8
3.5 [TEST] menu.....	3-12
3.6 [DS-8510 DATA]/[DS-8520 DATA] sub menu.....	3-20
3.7 [EQUIP RESET] sub menu	3-20
3.8 How to Set SFI.....	3-20
3.9 How to Offset for Analog Port	3-21
APPX. 1 JIS CABLE GUIDE	AP-1
APPX. 2 DIGITAL INTERFACE	AP-2
APPX. 3 CALIBRATION	AP-7
PACKING LIST(S)	A-1
OUTLINE DRAWING(S)	D-1
INTERCONNECTION DIAGRAM(S)	S-1

**FURUNO ELECTRIC CO., LTD.**www.furuno.com

All brand and product names are trademarks, registered trademarks or service marks of their respective holders.

FURUNO ELECTRIC CO., LTD.

9-52 Ashihara-cho,
Nishinomiya, 662-8580, JAPAN

• FURUNO Authorized Distributor/Dealer

All rights reserved. Printed in Japan

Pub. No. IME-72880-C3

(SEHA) DS-85

A : MAY 2020
C3 : OCT. 31, 2022





0 0 0 1 9 7 1 3 9 1 2



SAFETY INSTRUCTIONS

The installer must read the applicable safety instructions before attempting to operate or install the equipment.

 **WARNING** Indicates a potentially hazardous situation which, if not avoided, could result in death or serious injury.

 **CAUTION** Indicates a potentially hazardous situation which, if not avoided, can result in minor or moderate injury.

 Warning, Caution  Prohibitive Action  Mandatory Action

 **WARNING**

 **Do not open the equipment.**
This equipment uses high voltage electricity which can shock, burn or cause serious injury. Only qualified personnel can work inside the equipment.

 **Turn off the power at the mains switchboard before beginning the installation.**
Fire, electrical shock or serious injury can result if the power is left on or is applied while the equipment is being installed.

 **Do not install the equipment where it may get wet from rain or water splash.**
Water can cause fire or electrical shock, or damage the equipment.

Careful consideration is required to avoid ingress of water through the transducer tank. The tank shall be strong enough to withstand the water pressure in fully loaded conditions in rough weathers. FURUNO Electric Co., Ltd. is not liable to any loss of ship and personnel which is caused by installation procedures.

 **CAUTION**

 **Be sure to power each unit with proper voltage.**
Connection of an improper power supply can cause fire or damage the equipment.

 **Ground the equipment to prevent electrical shock and mutual interference.**

 **Observe the following safe compass distances to prevent interference to a magnetic compass:**

	Standard compass	Steering compass
Display Unit (DS-8500)	0.50 m	0.35 m
Distributor Unit (DS-8510)	2.30 m	1.45 m
Transceiver Unit (DS-8520)	1.95 m	1.25 m
Junction Box (CI-630)	2.00 m	1.15 m

SYSTEM CONFIGURATION

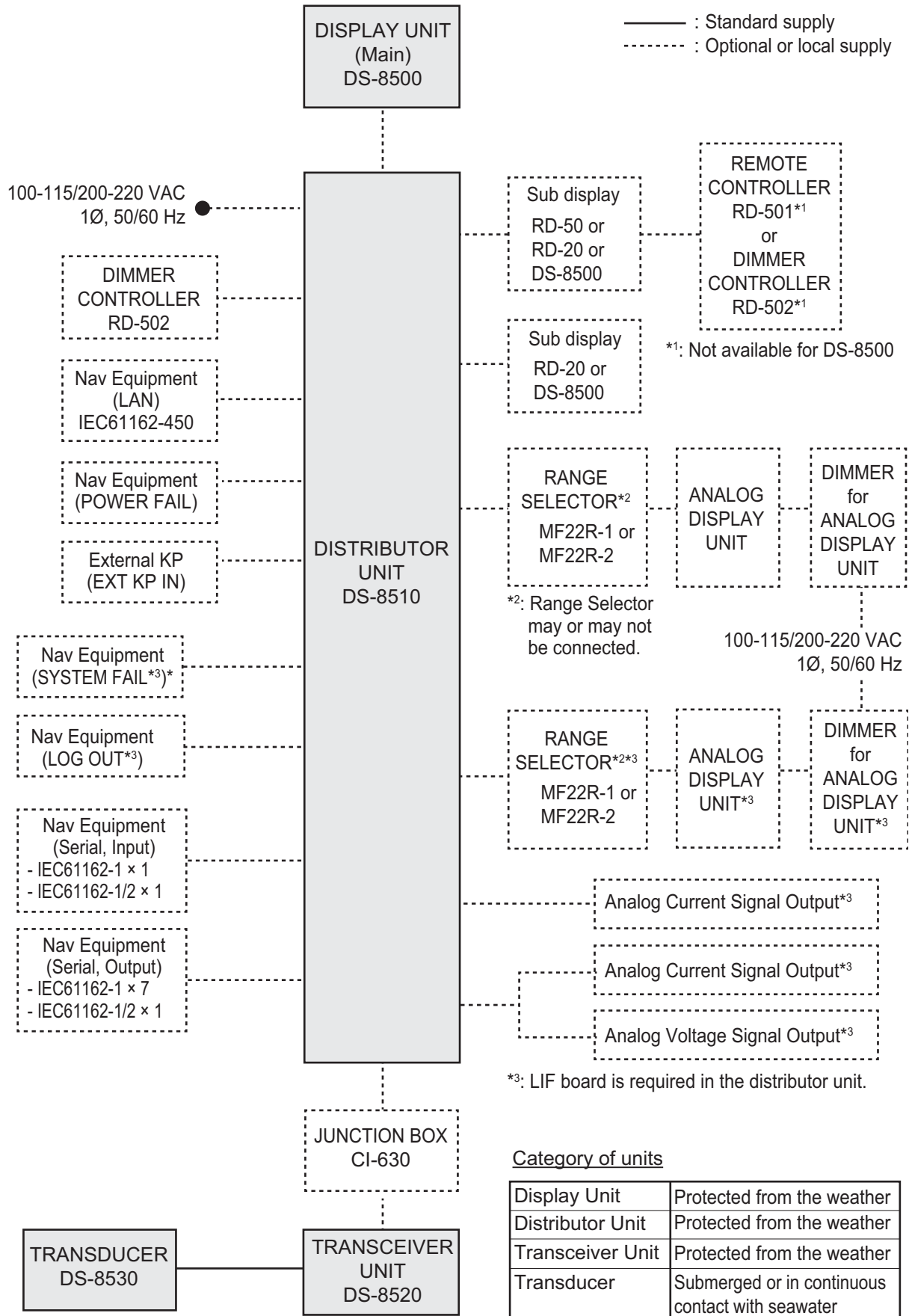

EQUIPMENT LISTS

Standard supply

Name	Type	Code No.	Qty	Remarks
Display Unit	DS-8500	–	1	
Distributor Unit	DS-8510-1	–	1	For 100 VDC, no LIF board
	DS-8510-2	–	1	For 200 VDC, no LIF board
	DS-8510-1-LIF	–	1	For 100 VDC, w/LIF board
	DS-8510-2-LIF	–	1	For 200 VDC, w/LIF board
Transceiver Unit	DS-8520	–	1	
Transducer	DS-8530	–	1	10/20/30/40 m cable
Installation Materials	CP05-13701	001-426-520	1	For DS-8500
	CP65-01501	001-569-940	1	For DS-8510
	CP65-01401	001-569-870	1	For DS-8520
Spare Parts	SP65-01101	001-569-930	1	For DS-8510
	SP65-01001	001-569-860	1	For DS-8520

Optional equipment

Name	Type	Code No.	Remarks (*: degree of protection, **: See section 1.5.3)					
Display Unit	DS-8500	–	For sub display					
Remote Display	RD-50	–						
	RD-20	–						
Analog Indicator	FL-200S-1	000-015-997-10	Flush mount	Scale range: -10 to 30 kn	IP5X*			
	FL-200S-1W	000-020-297-10		Scale range: -10 to 30, -2 to 6 kn (double scale**)				
	FL-200S-2	000-015-998-10		Scale range: -10 to 40 kn				
	FL-200S-3	000-020-296-10		Scale range: -10 to 20 kn				
	SL-200-1W	000-034-151	Bulk-head	Scale range: -10 to 30, -2 to 6 kn (double scale**)	IP56*			
	SL-200-5W	000-034-152		Scale range: 30 to -10, 6 to -2 kn (double scale**)				
	SL-200-1	000-016-000-10		Scale range: -10 to 30 kn				
	SL-200-2	000-016-164-10		Scale range: -10 to 40 kn				
	SL-200-3	000-029-425		Scale range: -10 to 20 kn				
	SL-200-4	000-037-721		Scale range: -10 to 30, -2 to 6 KTS (double scale**)				
	SL-200-5	000-037-722		Scale range: 30 to -10 kn				
	Range Selector	MF-22R-1		000-069-391		Flush mount		
		MF-22R-2		000-069-392		Bulkhead		

EQUIPMENT LISTS

Name	Type	Code No.	Remarks (*: degree of protection, **: See section 1.5.3)			
Dimmer	DS-F25	000-034-147	Flush mount	100-110 VAC	For analog indicator	IP5X*
	DS-FE25	000-034-148		200-220 VAC		
	DS-S25	000-034-149	Bulk- head	100-110 VAC		IP56*
	DS-SE25	000-034-150		200-220 VAC		
Dimmer Controller	RD-502	—	For remote operation			
Remote Controller	RD-501	—	For RD-50, RD-20			
Junction Box	CI-630	—				
Transducer Tank	DS-781	—	Projection type, replaceable on deck			
	DS-784	—	Flush type, replaceable on deck			
	DS-786	—	Gate valve type, replaceable on sea			
	DS-854	—	Ball valve type, replaceable on sea			
Front Fixing Panel	OP24-35	001-247-240	For DS-8500			
Waterproof Kit	OP05-139	001-426-500	For waterproof of DS-8500			
Replacement Kit	OP05-140	001-426-510	For retrofit of display unit from DS-800 to DS-8500			
F_Mount Cushion Kit	OP05-141	001-436-880	For DS-8500			
Cable Protection Kit	OP05-147	001-542-580	For Z-AWG25X4P-SB L050/100 (for DS-8500)			
Cable Assembly	OP05-146-1	001-542-230	For DS-8500, w/Z-AWG25X4P-SB L050 (5 m), gasket and cable tie.			
	OP05-146-2	001-542-240	For DS-8500, w/Z-AWG25X4P-SB L100 (10 m), gasket and cable tie.			
LIF Board Kit	OP65-3	001-564-490	For analog output			
SC Lock	OP65-4	001-571-420	For TTYCSLA-4 cable or unspecified ca- ble (applicable diameter ϕ 14.5 to 16.5)			
Installation Materials	CP24-02900	001-208-050	LAN cable 10 m			
	CP24-02910	001-208-060	LAN cable 20 m			
	CP24-02920	001-208-070	LAN cable 30 m			

1. MOUNTING

NOTICE

Do not apply paint, anti-corrosive sealant or contact spray to coating or plastic parts of the equipment.

Those items contain organic solvents that can damage coating and plastic parts, especially plastic connectors.

1.1 Display Unit

The display unit (main or sub) can be installed on a desktop, overhead, on the bulk-head or flush mounted in a console or panel.

1.1.1 Installation considerations

When selecting a mounting location for the display unit, keep the following in mind:

- Keep the unit out of direct sunlight.
- The temperature and humidity of the mounting location should be moderate and stable.
- Locate the unit away from exhaust pipes and vents.
- The mounting location should be well ventilated.
- Mount the unit where shock and vibration are minimal.
- Keep the unit away from electromagnetic field-generating equipment such as motors and generators.
- For maintenance and checking purposes, leave sufficient space at the sides and rear of the unit and leave slack in cables. Refer to the outline drawings at the back of this manual.
- A magnetic compass will be affected if the display unit is too close to it. Observe the compass safe distances to prevent disturbance to the magnetic compass. Refer to the compass safety distances of the units on "SAFETY INSTRUCTIONS" page.
- For flush mounting in a panel, the mounting surface must be flat. Do not install the unit on an uneven surface.
- To avoid damage to the cabling when mounting the display unit, make sure the cabling is not excessively bent.

Note: The cabling to the display unit should be completed before mounting the unit. See section 2.3.2.

1. MOUNTING

Grounding

Ground the unit with the supplied ground wire referring to the figure to the right.

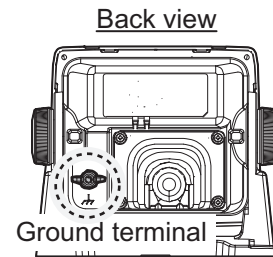

1.1.2 How to fit the cable gasket (When using the OP05-146-1 or OP05-146-2)

When using the cable assembly OP05-146-1 (5 m) or OP05-146-2 (10 m), its waterproofing capability can be increased by attaching the cable gasket attached to the cable assembly.

The cable gasket needs to be attached to the cable as shown below. The cut line must face downward to prevent the water intrusion to the unit.

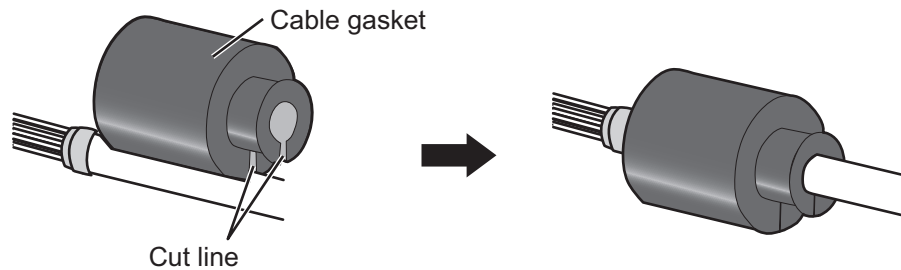

Regarding how to connect the cabling to the Display and how to fit the cable gasket to the cable clamp, referring to section 2.3.2.

1.1.3 How to fit the optional waterproofing kit (OP05-139)

The optional waterproofing kit (OP05-139) must be fitted at the same time as the cabling is connected to the display unit.

The waterproofing kit (OP05-139) contains the following items:

- Cover gasket (Type: 05-109-3504, Code:100-403-800-*) ×1
 - Cable gasket (Type: 05-109-3503, Code: 100-403-792-*) ×1
1. Unfasten the four screws on the rear cable clamp, then remove the cable clamp to reveal the WAGO connector.

2. Fit the cable gasket to the cable clamp, referring to the figure below.

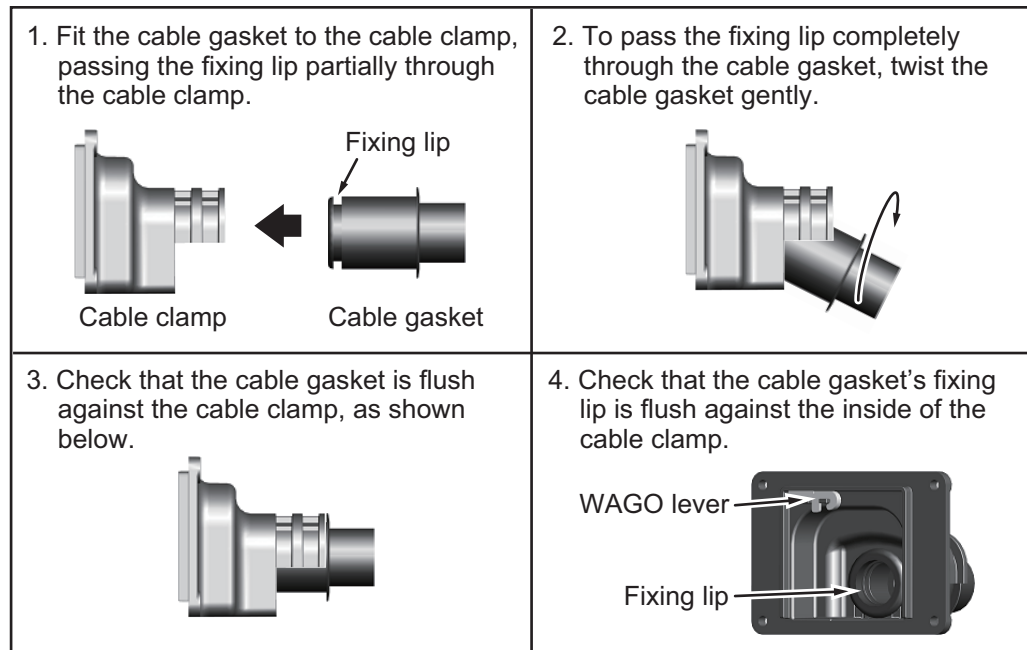

3. Pass the cabling through the cable gasket and cable clamp.
Note: To maintain the IPX5 waterproof rating, the cable must be TTYCSLA-4 (or equivalent) with a diameter of $\phi 14.4 \pm 0.4$ mm.
4. Fit the cover gasket to the rear of the display unit. Make sure the cover gasket is placed inside the groove indicated in the figure below.

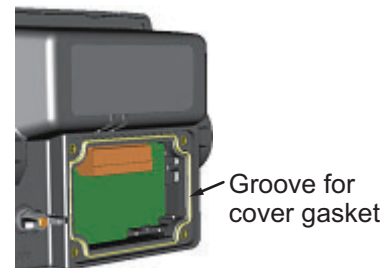

5. Connect the cabling to the display unit, referring to section 2.3.2.
6. Slide the cable clamp along the cable until the clamp is flush against the rear of the display unit.

Note: The cable clamp must be oriented with the dome-side up, to prevent water intrusion.

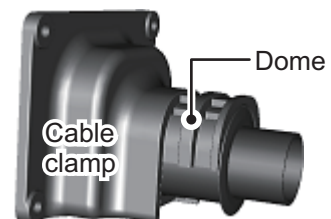

7. Fasten the four screws removed at step 1.
8. Secure the cabling to the cable clamp with cable ties (local supply) referring to the figure in section 2.3.2.

1.1.4 How to install the display unit on a desktop or overhead

The display unit is shipped with the hanger.

- Place the display unit on a firm, flat surface, then unfasten the two knobs on either side of the display unit to separate the display unit and hanger.
- Drill four holes for the self-tapping screws ($\phi 5 \times 20$) at the installation location.

1. MOUNTING

- Secure the hanger to the desktop or overhead with four self-tapping screws ($\phi 5 \times 20$, installation material). The hanger should be oriented with the insertion slots facing forward. For mounting dimensions and required clearance, see the outline drawing at the back of this manual.

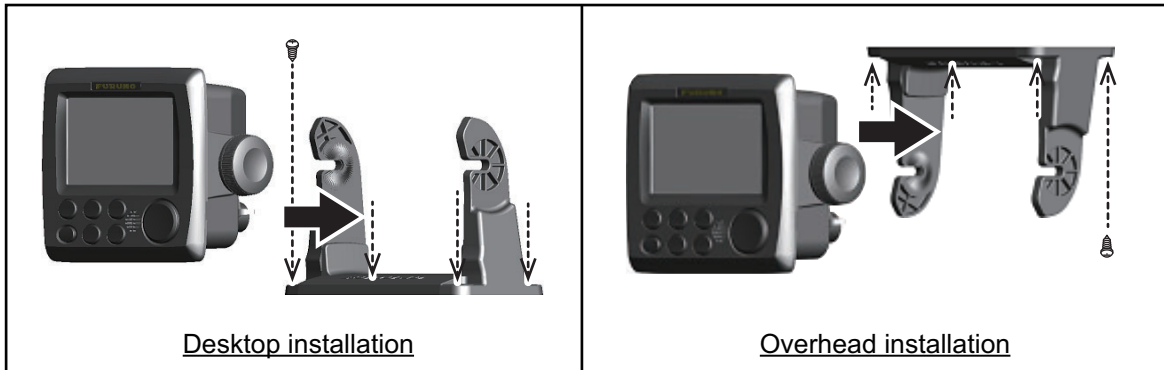

- Referring to section 2.3.2, connect the cabling to the display unit.
- Fit the display unit to the hanger and tighten the bolts on either side evenly. Adjust the angle of the display unit so that the screen can be viewed clearly.

1.1.5 How to flush mount the display unit

There are two methods for flush mounting the display unit, flush mounting the display unit directly to the installation location or with using the optional front fixing panel kit.

Note: For flush mounting in a panel, the mounting surface must be flat. Do not install the unit on an uneven surface.

Flush mounting the display unit (unit only)

- Cut a hole in the installation location, using the template at the back of this manual.
- Drill four holes for the self-tapping screws ($\phi 3 \times 20$).
- Place the display unit on a firm, flat surface, then unfasten the two knobs on either side of the display unit to separate the display unit and a hanger. The hanger can be disposed.
- Gently lift the locking tabs at the rear of the front panel, then the remove the front panel. Be careful not to damage the locking tabs or the front panel.

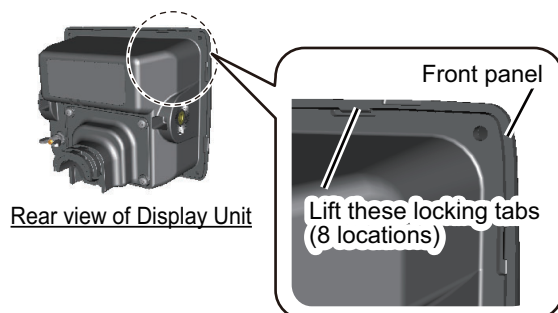

- Fit the supplied F Mount Cushion (20-032-1064) to the rear of the display unit or to the installation hole.

- Run the cabling through the cutout, then, referring to section 2.3.2, connect the necessary cabling to the display unit.

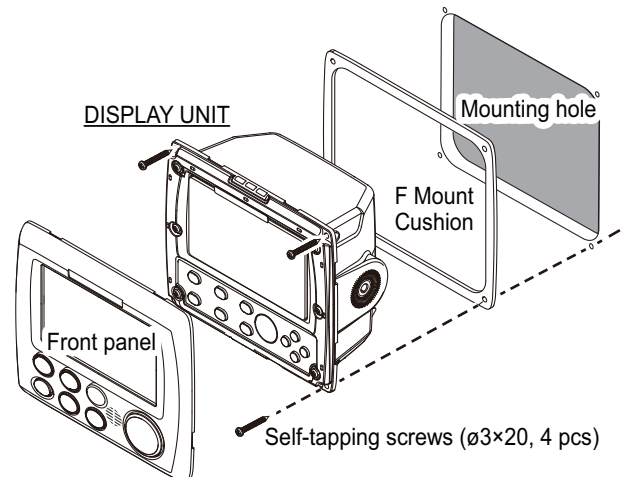

- Referring to the figure above, fit the display unit to the cutout, then use the supplied self-tapping screws ($\phi 3 \times 20$) to secure the display unit to the flush mount panel.
- Re-attach the front panel detached at step 4.

Flush mounting the display unit (with optional front fixing panel kit)

Use the optional kit (OP24-35), referring to the outline drawings at the back of this manual and the installation instructions (C42-01310) included with the optional kit.

1.2 Distributor Unit

This unit can be installed on a bulkhead or on the floor. Install it referring to the outline drawing at the back of this manual for dimensions.

1.2.1 Installation consideration

When selecting a mounting location for the distributor unit, keep the following in mind:

- Keep the distributor unit out of direct sunlight.
- The temperature and humidity should be moderate and stable.
- Locate the unit away from exhaust pipes and vents.
- The mounting location should be well ventilated.
- Mount the unit where shock and vibration are minimal.
- Keep the unit away from electromagnetic field generating equipment such as motors and generators.
- For maintenance and checking purposes, leave sufficient space at the sides and rear of the unit and leave slack in cables. Refer to the outline drawing.
- A magnetic compass will be affected if the unit is placed too close to it. Observe the following compass safe distances to prevent disturbance to the magnetic compass, referring to "SAFETY INSTRUCTIONS" on page i.
- Avoid floor mounting the distributor unit in locations where there is water splash. Keep the cable entry away from water spray and splash. For a bulkhead installation, install the unit so that the cable entrance must face downward.

1. MOUNTING

1.2.2 Mounting

Use M6 (supplied) or M8 (local supplied) screws. Note that the size of mounting holes etc. differ according to the screw size.

Note: For bulkhead installations, the cable entry must face downward.

1. Make four pilot holes, referring to the outline drawing at the back of this manual.
2. Fit two self-tapping screws at the location for the bottom fixing holes. Leave approximately 5 mm of thread exposed. The mounting holes and notches differ according to the mounting screws.

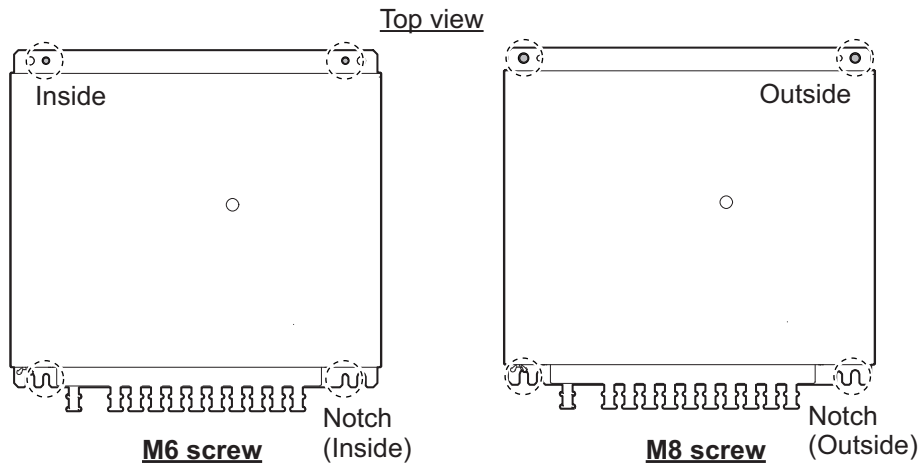

3. Place the distributor unit on the two screws and fasten two self-tapping screws to the top fixing holes.
4. Fasten the two self-tapping screws at the bottom fixing holes tightly.

Grounding

Ground the unit with the supplied ground wire referring to the figure to the right.

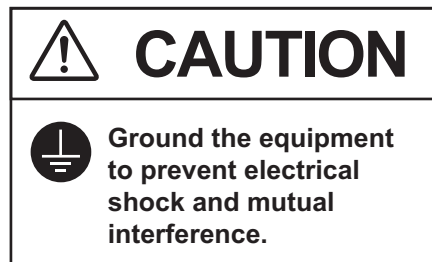
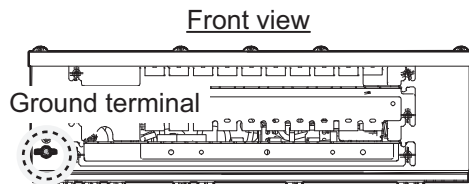

1.3 Transceiver Unit

This unit can be installed on a bulkhead.

1.3.1 Installation considerations

Keep in mind the following points when selecting a location.

- Locate the transceiver unit away from heat sources to prevent heat build up inside the cabinet.

- Select a location where the vibration is minimal. When installing the transceiver unit in a location with a lot of vibration such as a bow thruster room, use a vibration isolator (shipyard supply).
- Locate the equipment away from places subject to water splash and rain.
- Leave sufficient space at the sides and rear of the unit to facilitate maintenance.
- A magnetic compass will be affected if the processor unit is placed too close to the magnetic compass. Observe the compass safe distances in the "SAFETY INSTRUCTIONS" on page i to prevent interference to a magnetic compass.
- For the mounting direction, the cable entry must face downward.
- Referring to the weight of this unit, indicated in the outline drawings at the back of this manual, reinforce the mounting location if necessary.

1.3.2 How to install the transceiver unit

Use M6 (supplied) or M8 (local supplied) screws. Note that the size of mounting holes differ according to the screw size.

Note: For bulkhead installations, the cable entry must face downward.

1. Make four pilot holes, referring to the outline drawing at the back of this manual.
2. Fit two self-tapping screws at the location for the bottom fixing holes. Leave approximately 5 mm of thread exposed. The mounting holes and notches differ according to the mounting screws.
3. Place the transceiver unit on the two screws and fasten two self-tapping screws to the top fixing holes.
4. Fasten the two self-tapping screws at the bottom fixing holes tightly.

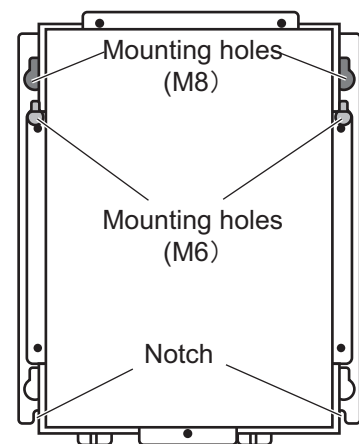

Top view

Grounding

Ground the unit with the supplied ground wire referring to the figure below.

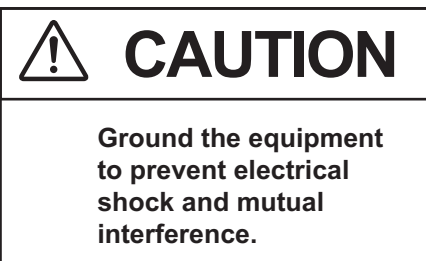
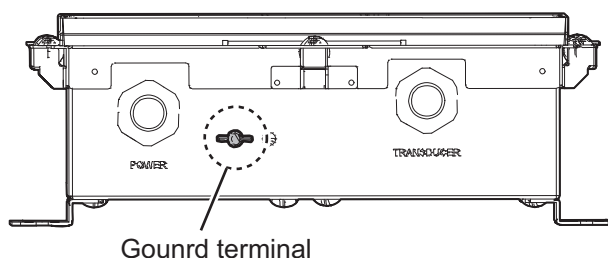

1.4 Transducer

The performance of this equipment is directly dependent on the installation of the transducer. The installation of the transducer and the tank should be accomplished by a dockyard referring to the installation drawings at the back of this manual.

Also, the transducer DS-820 which is used for DS-80 is available. For installation of DS-820, see the installation manual (IME-72470) for DS-80.

1.4.1 Installation considerations

To decide the location of the transducer, the following points should be taken into account.

- Locate the transducer DS-8530 at least 2.5 m from the transducer of an echo sounder.

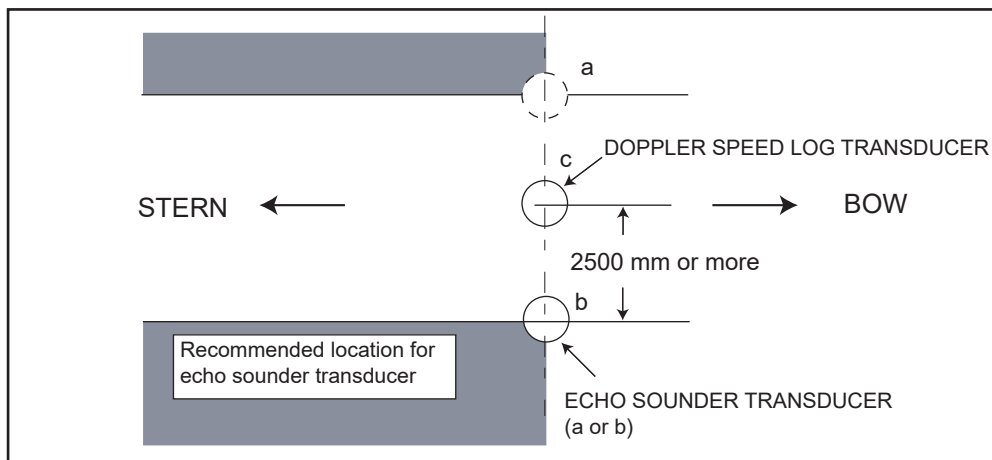

Transducer, mounting location

- Separate as far as possible from air bubble sources; e.g., side thruster and water disposal pipes.
- The Doppler speed log emits ultrasonic waves diagonally forward and backward, so the transducer should not be located on the same line of the Doppler speed log in the bow-stern direction.
- Install in close proximity to the keel, for uniform water flow.
The closer the ship is to the keel line, the more the water flow at the bottom of the vessel creates an arrhythmic flow parallel to the keel, thus reducing errors in speed measurement.
- Generally, best performance is obtained by mounting on the bow; the stern side is influenced more easily by air bubbles and propeller cavitation.
- Never apply ordinary ship bottom paint to the transducer face. Whenever the ship is dry docked, the transducer face should be cleaned, removing marine life and foreign material.
- For DS-784 (flush type), DS-786 (gate valve type) or DS-854 (ball valve type) transducer tank, remove the hose clamp of the transducer.
For DS-781 (projection type), the hose clamp is required even if it is removed temporarily under installation.
- Do not remove the metal pipe on the outside of the transducer. Please mount the transducer with the metal pipe attached to prevent reverberation.

- Refer to the procedure below for the location where the supplied liquid gasket TB1121 is applied. For DS-781 (projection type) bottom tank, there is no place to apply the liquid gasket.

1.4.2 How to install the transducer

DS-784 (Mounting of Flush Type Seachest)

The seachest DS-784 is delivered temporarily assembled with the transducer.

1. Loosen lock nut (5) with a wrench (hex. size: 50 mm) and take off cap nut (4) from top cover (3) together with gasket (6) and flat washer (7). (It is not necessary to draw the cap nut completely out from the cable.)
2. Unscrew hex. socket head bolts (9) (M12×25, 4 pcs.) with a socket screw wrench (size: 10 mm). Separate the seachest (2) and transducer (1) from top cover (3). Handle O-ring (8) carefully.
3. Align the "FORE" mark on the side of the seachest to face the fore direction, parallel with the fore-aft line of the ship (a 1 degree error margin is allowed), then weld the seachest to the hull plate. The seachest should also be level with ship's normal trim within 1 degree.
4. Finish the outside hull plate with a grinder to ensure smooth water-flow.
5. Apply "Kinoruster (Anti-crevice corrosive sealant)" to face A of the seachest (2), O-ring groove on the hull flange, O-ring (8) and face A of the stop cover (3).
6. Fit O-ring (8) onto the O-ring groove.
7. Place transducer (1) into the seachest (2) so that the alignment nipple on the transducer face fits into the notch on the hull flange.
8. Clean the hull flange face with a clean cloth and fit the stop cover (3) on the hull flange.
9. Tighten hex. socket bolts (9) with a socket screw wrench.
10. Fit the gasket (6) and flat washer (7) over the transducer flange and tighten cap nut (4) securely with a wrench (hex. size: 50 mm). Screw lock nut (5).
11. When running the transducer cable inside the conduit pipe, screw the pipe onto the cap nut (PS3/4) for watertightness.

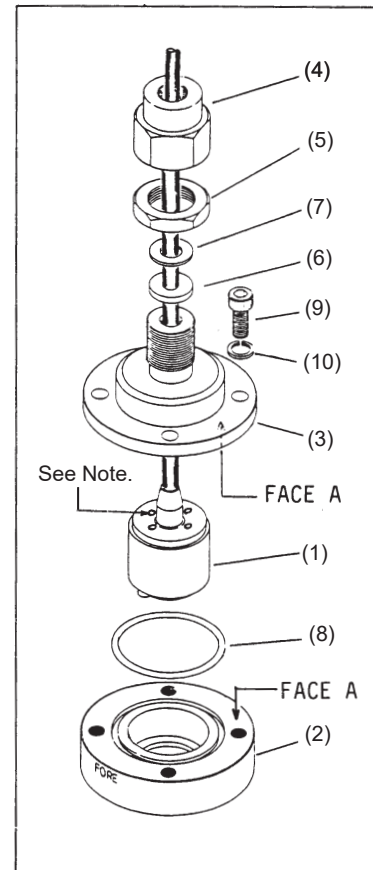

Note: Never remove the four flat head screws on the transducer. These are sealing screws and are required to maintain watertightness.

1. MOUNTING

DS-786 (Mounting of Gate Valve Type Seachest)

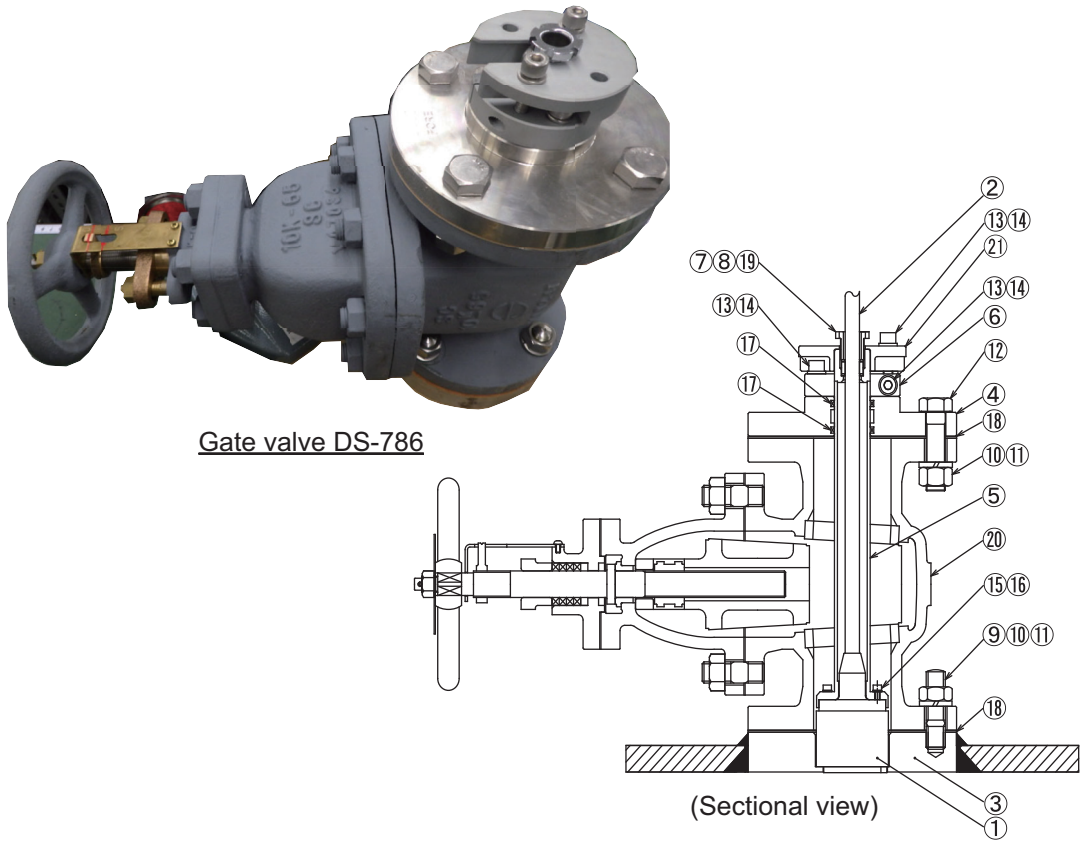

Gate valve DS-786

(Sectional view)

Note: The gate valve requires service space of 700 mm. For details, see the installation drawing at the back of this manual.

1. Unfasten M16 nut (3) and spring washer (11) from the assembled gate valve to remove the following five items.
 - 1) Gate valve (20)
 - 2) flange (3)
 - 3) Gasket 1 (18)
 - 4) Gasket 2 (18)
 - 5) Shaft assy.

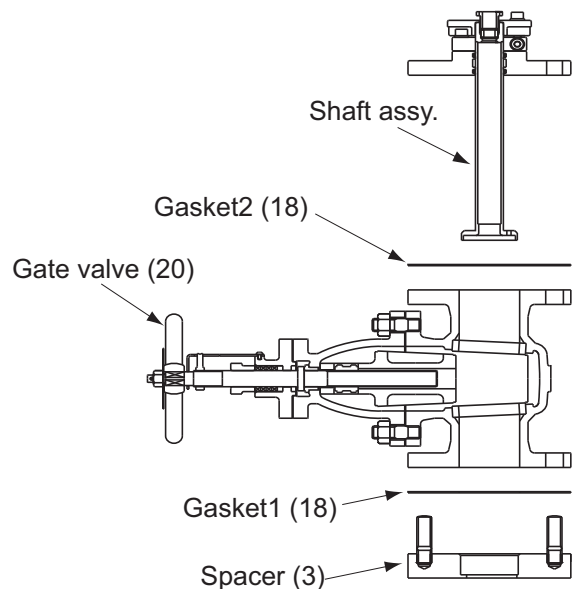

2. Set the flange (3) to the mounting location.
The "FORE-AFT" line on the spacer must be parallel with the ship's fore and aft line (within 1°). For horizontal direction, the bottom of the spacer must be parallel with the ship's draft.

Note: Handle the top side of the flange (3) carefully to preserve the waterproofing.

3. Weld the flange (3) to the ship's hull. The welding and doubling methods are left up to the shipyard.
4. Apply Kinoruster (supplied) to both sides of the gasket1 (18), and fit it to the flange (3).

5. Apply Kinoruster (supplied) to the hollow side of the flange (3).
6. Clean the top and bottom of the gate valve (20), and put it on the gasket1 (18) set on the flange (3).
7. Fasten M16 nut (10) and M16 spring washer (11) loosely to the stud bolt of the flange (3).
8. Paint the gate valve (20) and the flange (3) the same color as ship's body. Paint only gray-colored areas; for other parts, seal with masking tape. Remove the tape when the paint dries.

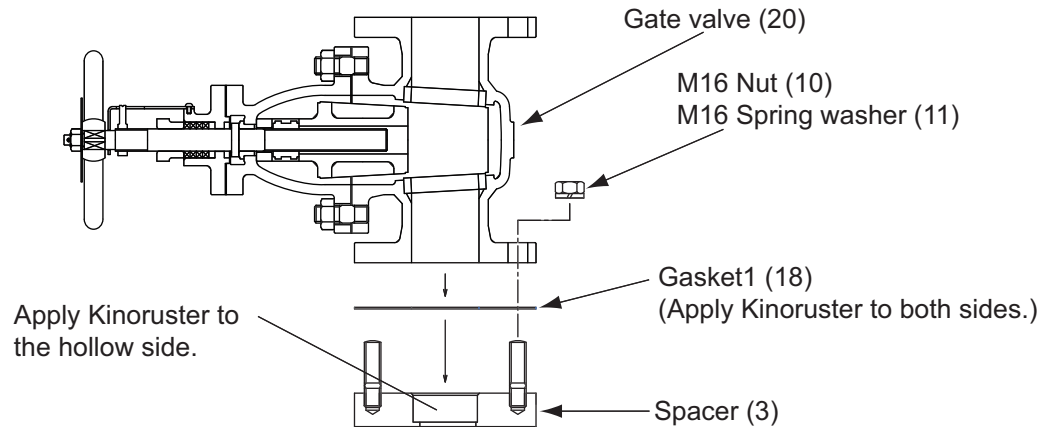

9. Unfasten two sets of hex. bolt (13) and M8 spring washer (14) from the top side of the shaft to remove the fixing plate (21).
10. Remove the gland (19), gasket (7) and washer (8)(2 pcs.) from the shaft.
11. Remove Jubilee clip located at the base of the transducer (1) cable and M4 flat-head Phillips screw at the top side of the transducer (1).

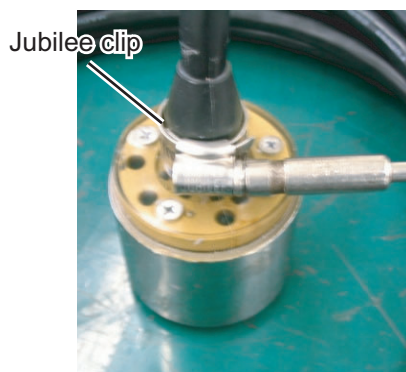

Removing Jubilee clip

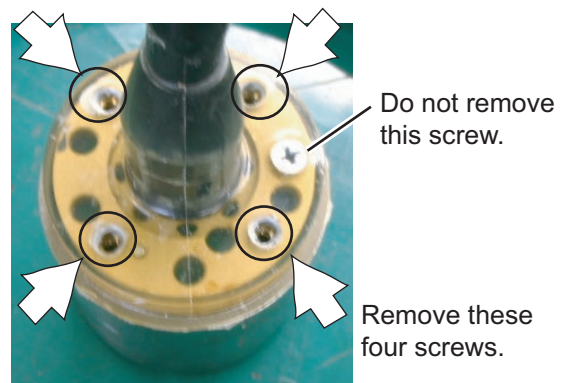

Removing flat-head Phillips screws

12. Pass the transducer cable through the shaft from the flange side.
13. Apply Three Bond (1104 200G:local supply) to the top side of the transducer evenly.

1. MOUNTING

14. Apply Three Bond to the thread part of hex. bolt (15) with seal washer (16) and use them to fasten the transducer. Check that the fore mark on the shaft is aligned with the projection at the bottom of the transducer.

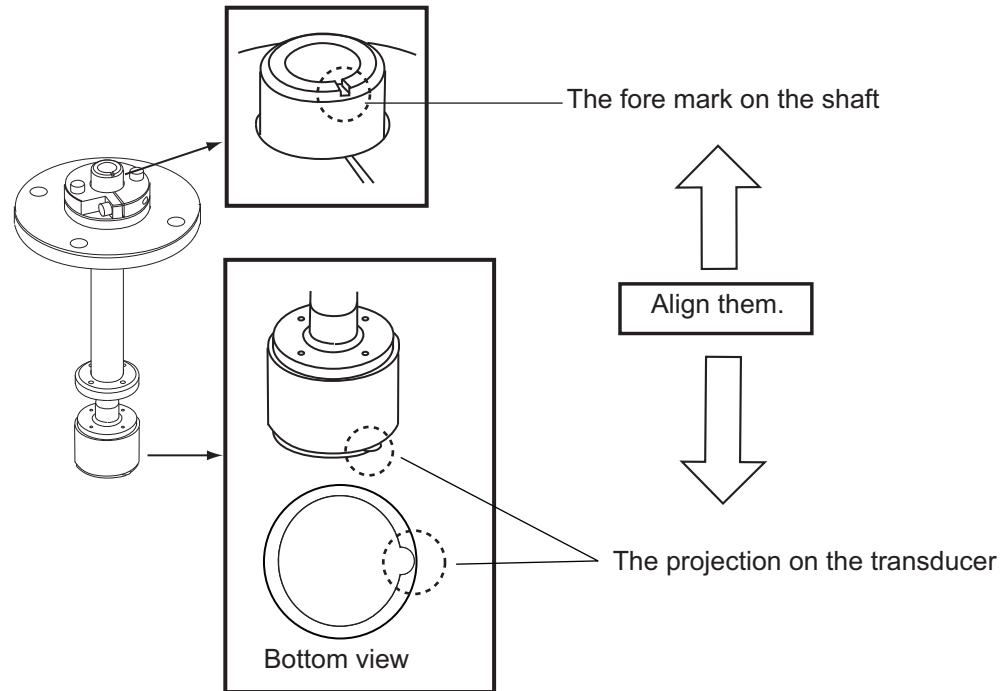

15. Pass the flat washer (8), gasket (7), washer (8), and the gland (19) onto the transducer cable.
16. Fasten the gland (19) to the top of the shaft (5).

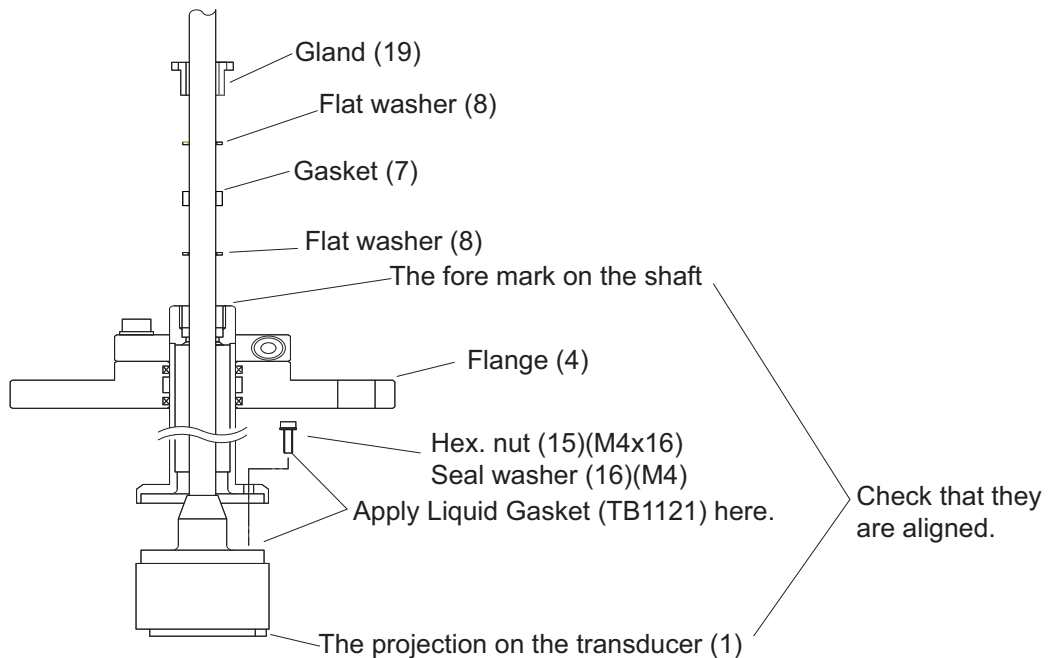

17. Apply Kinoruster to both sides of the gasket2 (18), and put it on the gate valve (20).
18. Put the shaft on the gasket2 (18), and align the hollow side on the flange (3) with the projection of the transducer (1).
19. Remove the M8 hex. bolt (13) and M8 spring washer (14) from the lock ring to free the shaft (5).

20. Use the M16 hex. bolt (12), M16 nut (10) and M16 spring washer (11) to fasten the flange (4) loosely.
21. Insert the shaft so the projection on the transducer fits in the groove on the flange (3). Move the shaft up and down by hand to confirm that it moves smoothly.
22. Tighten the M16 nut(8 pcs.) on the gate valve (20).

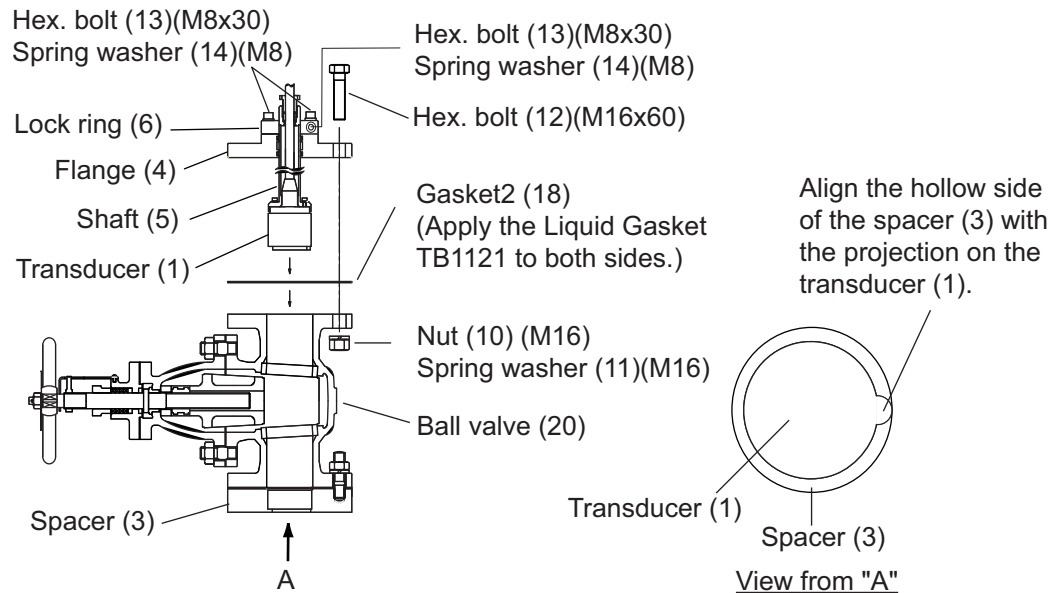

23. Loosely fasten two sets of M8 hex. bolt (13) and M8 spring washer (14) at the top side of the lock ring (6).
24. Tightly fasten the M8 hex. bolt (13) tightly and the M8 spring washer (14) at the lateral side of the lock ring.
25. Loosely fasten two sets of M8 hex. bolt (13) and M8 spring washer (14) fastened at step 23.

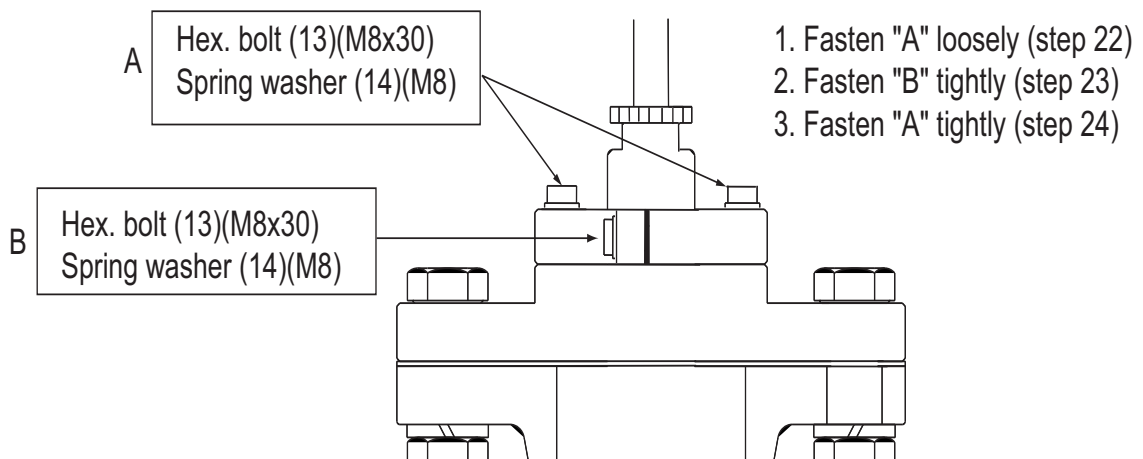

26. Put the fixing plate (21) between the shaft (5) and gland (19). Fasten the plate with two sets of M8 hex. bolt (13) and M8 spring washer (14). Check the clearance between the fixing plate (21) and the lock ring (6). If the clearance is more than 3

1. MOUNTING

mm, be sure to check that the hollow side of the flange (3) is aligned with the projection on the transducer (1).

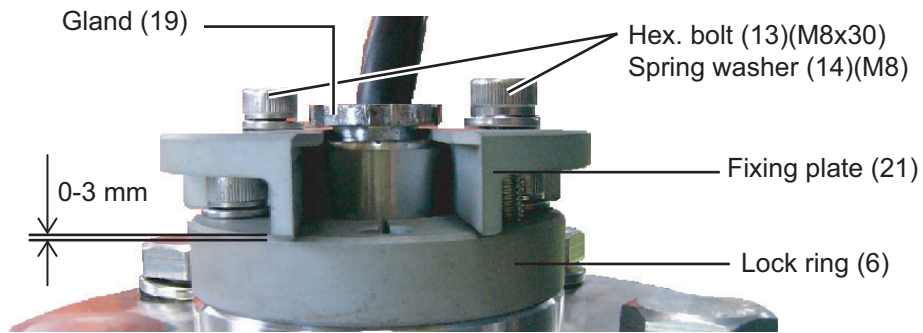

27. Check that all bolts are fastened tightly.

<How to open/close the gate valve>

1. Loosen the two nuts fixing the gland gasket until the handle can be turned.
2. Operate the handle to open or close the gate valve.

When closing the gate valve;
If additional tightening is necessary after turning the handle by hand, prepare separate handle extensions. Tighten again using the handle extension until the main handle can no longer be turned. For the size and usage of the handle extension, refer to the figure below.

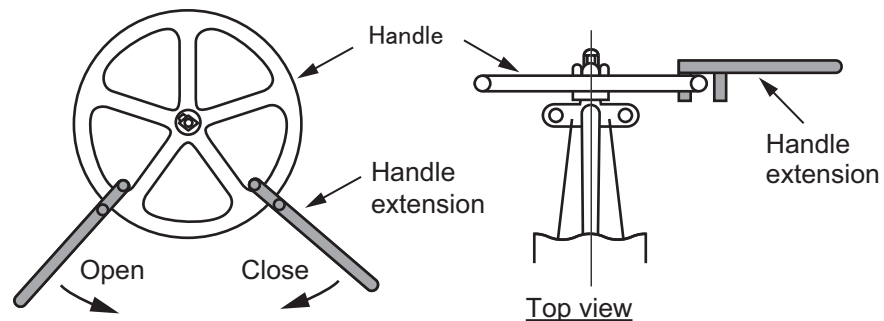
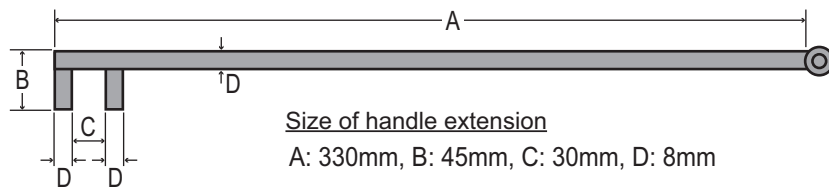
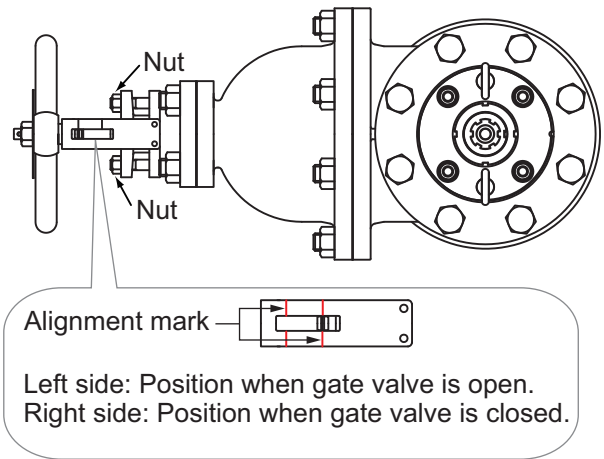

3. After opening or closing the gate valve, tighten the loosened nuts until the handle cannot be turned.

DS-781 (Mounting of Projection Type Seachest)

1. Weld doubling plate (supplied by shipyard) to hull plate.
2. Remove the M10 bolts, and take out transducer fixing flange (2) (including transducer) from transducer housing (1).
3. Determine the projection distance, and cut transducer housing (1). The horizontal error should be within 1°.
4. Before beginning this step, remove the rubber gasket inside the thru-hull pipe to prevent it from melting. After cutting a hole through the hull plate for the thru-hull pipe (φ36), weld the thru-hull pipe to the hull plate.
5. Weld the transducer housing (1) to the plate. Direction error from fore-aft line should be within 1°. At the stern side of the transducer housing, make air exhaust holes (φ10-20).
6. Through the thru-hull pipe, pull up the transducer cable into the ship. Be careful not to jam the cable between the flange and housing. Next, using the two M10×30 bolts ("Kinoruster" applied) fasten the transducer fixing flange to the transducer housing.

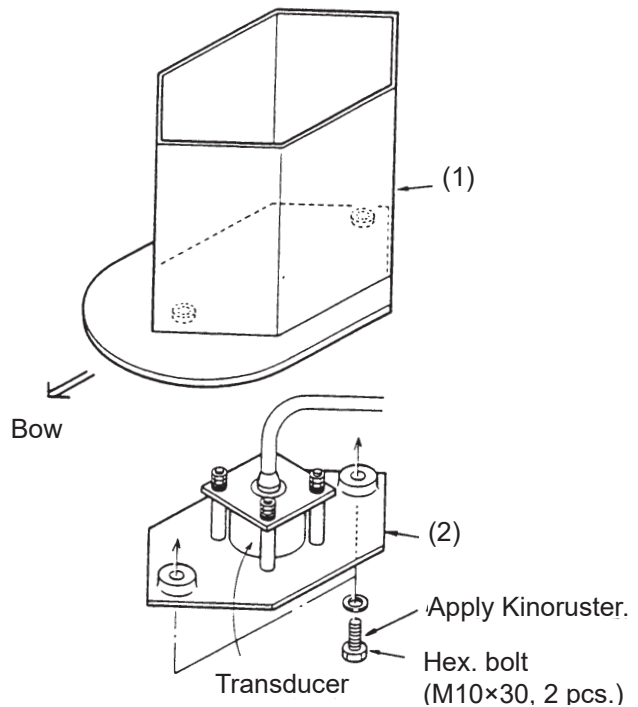

Note: Never remove the four flat head screws on the transducer. These are sealing screws and are required to maintain watertightness.

1. MOUNTING

DS-854 (Ball valve, Transducer)



Ball valve DS-854

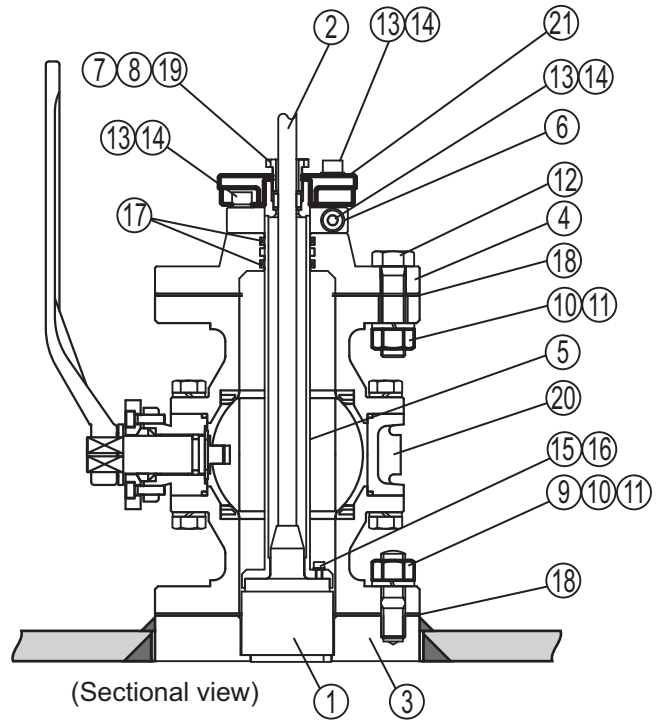

(Sectional view)

Note 1: The liquid gasket for installation may not be supplied due to export regulations. If the liquid gasket TB1121 is not included in the installation materials, prepare the liquid gasket specified in your country.

Note 2: The ball valve requires service space of 700 mm. For details, see the installation drawing at the back of this manual.

1. Unfasten M16 nut (10) and flat washer (11) from the assembled gate valve to remove the five items shown below.

- Ball valve (20)
- Flange (3)
- Gasket 1(18)
- Gasket 2(18)
- Shaft assy.

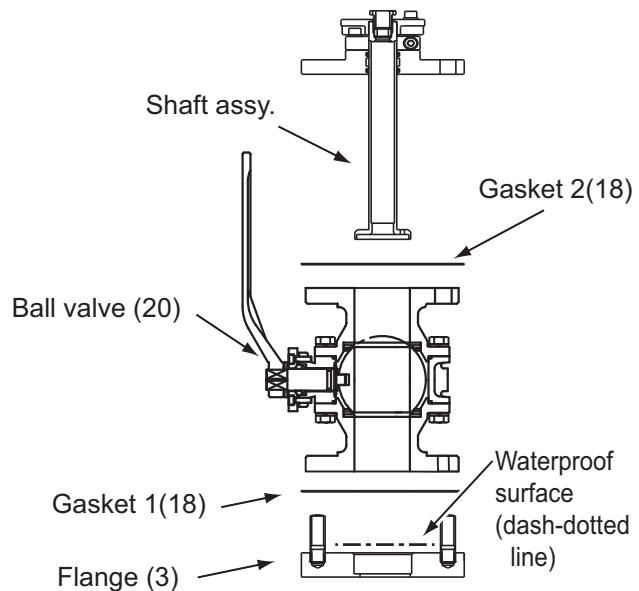

2. Set the flange (3) to the mounting location. The "FORE-AFT" line on the spacer must be parallel with the ship's fore and aft line (within 1). For horizontal direction, the bottom of the spacer must be parallel with the ship's draft.

Note: Do not paint the top side of the flange (3) and handle it carefully to preserve the waterproofing.

3. Weld the flange (3) to the ship's hull. The welding and doubling methods are left up to the shipyard.
4. Apply the Liquid gasket TB1121 to both sides of the gasket1 (18), and put it on the flange (3) which is indicated as "dashed-dotted line" (mounting surface for the Gasket 1 (18)) in the figure at step 1 on page 1-16.
5. Apply the Liquid gasket TB1121 to the hollow side of the flange (3).
6. Clean the top and bottom of the ball valve (20), and put it on the gasket1 (18) set on the flange (3).
7. Fasten M16 nut (10) and M16 flat washer (11) loosely to the stud bolt of the flange (3) loosely.

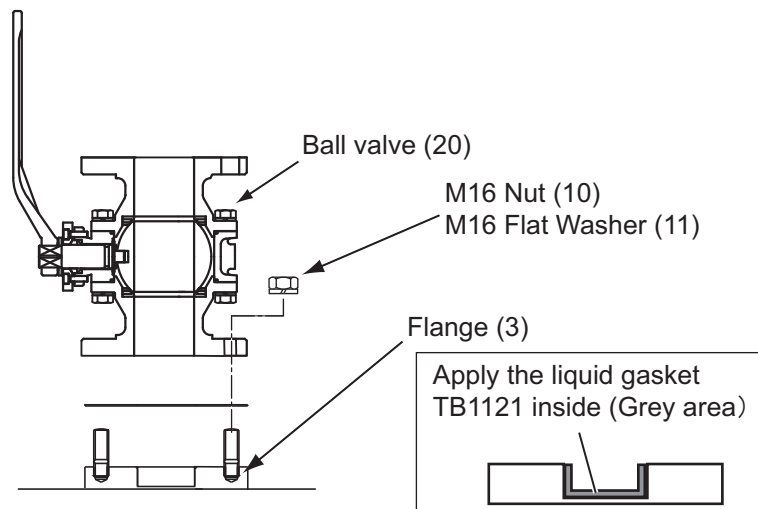

8. Unfasten two sets of hex. bolt (13) and M8 spring washer (14) from the top side of the shaft to remove the fixing plate (21).

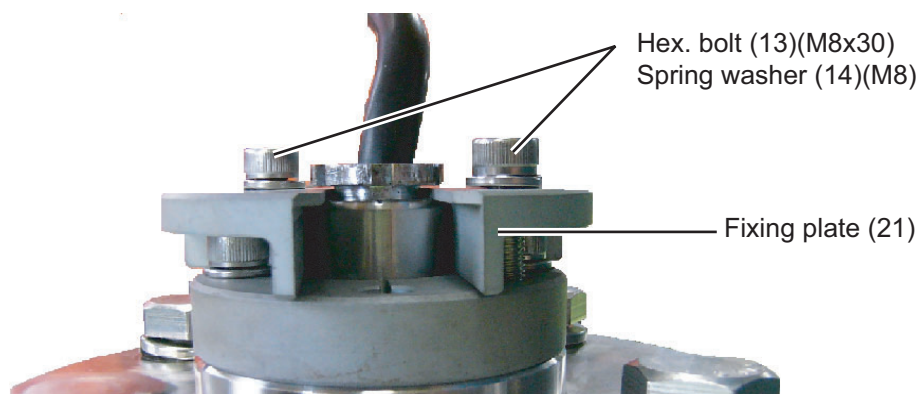

9. Remove the gland (19), gasket (7) and washer (8) (2 pcs.) from the shaft.

1. MOUNTING

10. Remove the Jubilee clip located at the base of the transducer (1) cable and four M4 flat-head Phillips screws at the top side of the transducer (1).

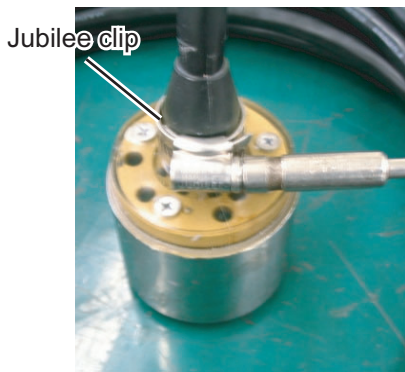

Removing Jubilee clip

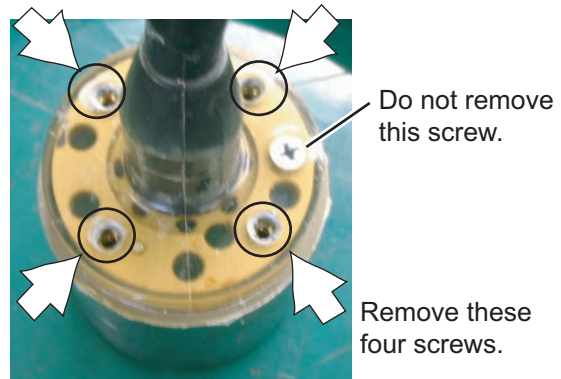

Removing flat-head Phillips screws

11. Pass the transducer cable through the shaft from the flange side.
12. Apply the Liquid Gasket TB1121 to the top side of the transducer evenly.
13. Apply the Liquid Gasket TB1121 to the thread part of hex. bolt (15) with seal washer (16) and use them to fasten the transducer.
Check that the fore mark on the shaft is aligned with the projection at the bottom of the transducer.

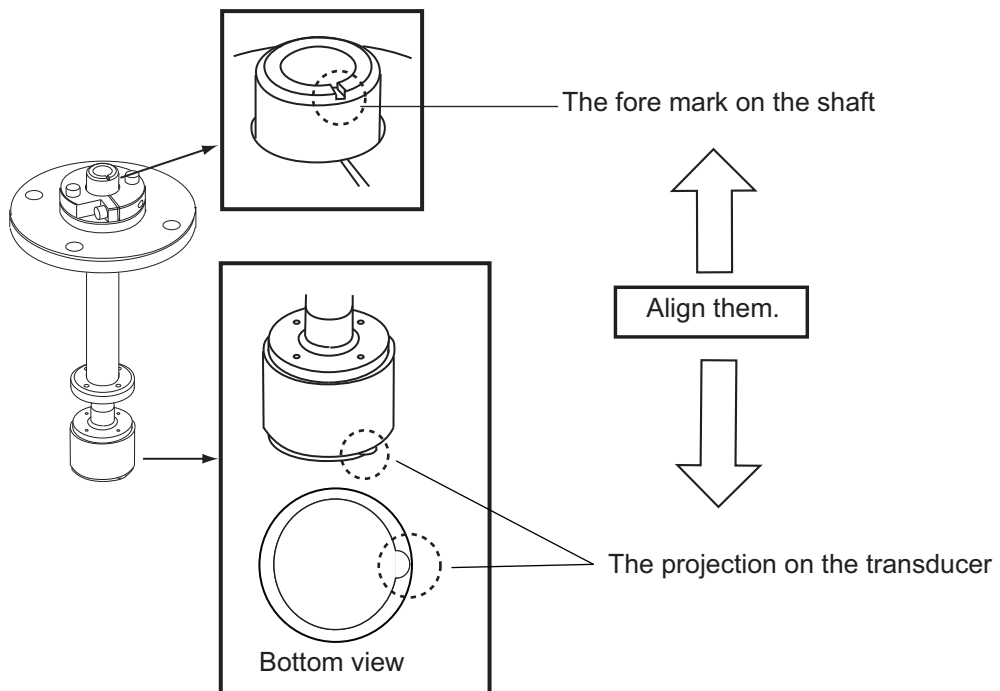

14. Pass the flat washer (8), gasket (7), washer (8), and the gland (19) onto the transducer cable.

15. Fasten the gland (19) to the top of the shaft (5).

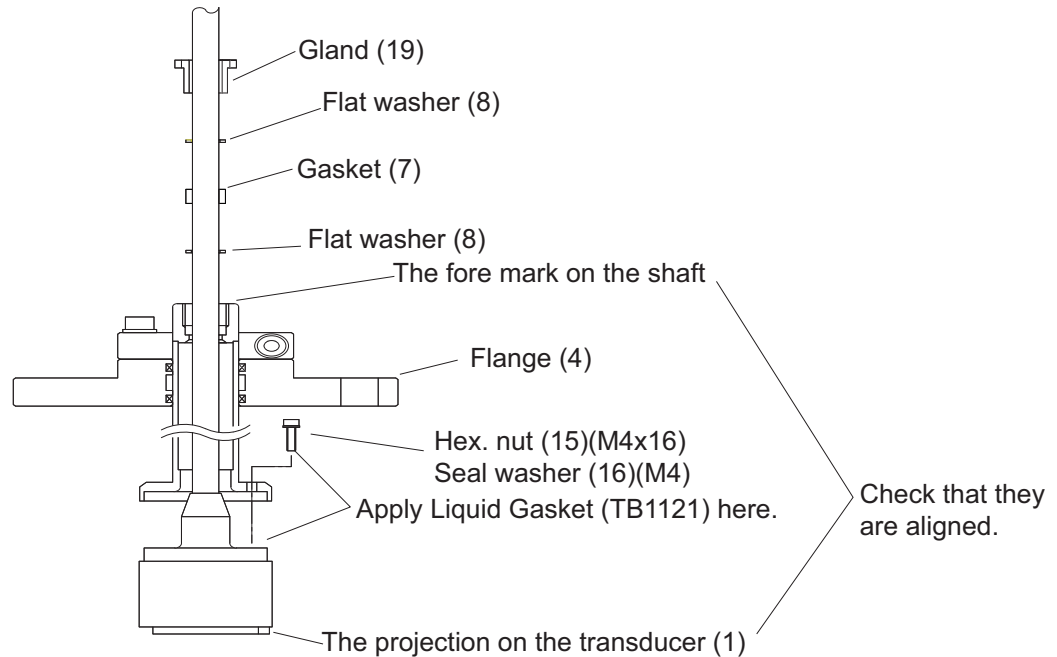

- 16. Apply the Liquid Gasket TB1121 to both sides of the gasket2 (18), and put it on the ball valve (20).
- 17. Put the shaft on the gasket2 (18), and align the hollow side on the flange (3) with the projection of the transducer (1).
- 18. Remove three M8 hex. bolts (13) and three M8 spring washers (14) from the lock ring (6) to free the shaft (5).
- 19. Fasten the flange (4) loosely with the M16 hex. bolt (12), M16 nut (10) and M16 flat washer (11).
- 20. Insert the shaft so the projection on the transducer (1) fits in the groove on the flange (3). Move the shaft up and down by hand to confirm that it moves smoothly.
- 21. Tighten the M16 nut (8 pcs.) on the ball valve (20).

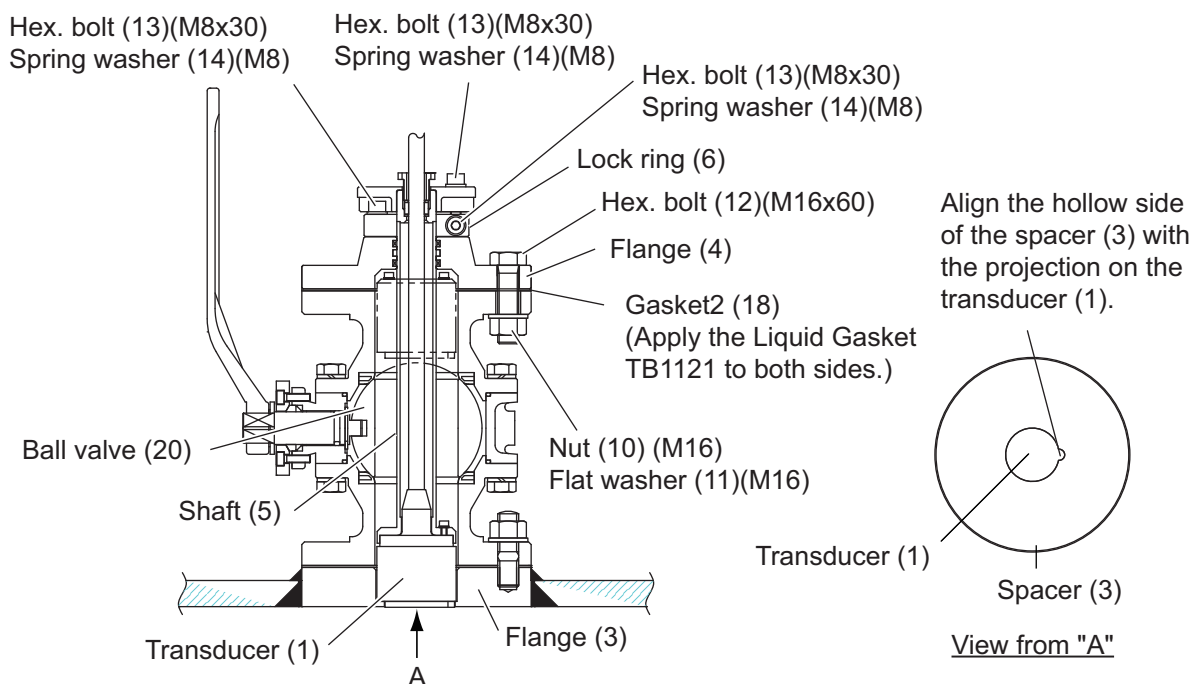

1. MOUNTING

22. Loosely fasten two sets of M8 hex. bolt (13) and M8 spring washer (14) at the top side of the lock ring (6).
23. Fasten the M8 hex. bolt (13) tightly and the M8 spring washer (14) at the lateral side of the lock ring (6) to fasten the shaft (5).
24. Fasten tightly two sets of M8 hex. bolt (13) and M8 spring washer (14) fastened at step 22.

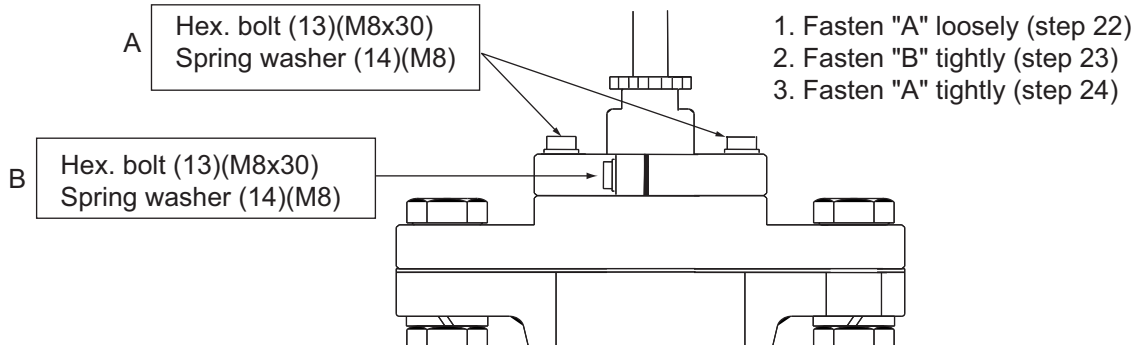

25. Put the fixing plate (21) between the shaft (5) and gland (19). Fasten the plate with two sets of M8 hex. bolt (13) and M8 spring washer (14). Check the clearance between the fixing plate (21) and the lock ring (6). If the clearance is more than 3 mm, be sure to check that the hollow side of the flange (3) is aligned with the projection on the transducer (1).

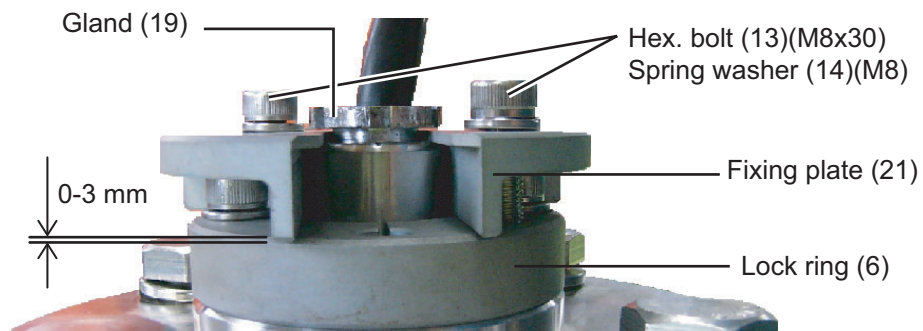

26. Check that all bolts are fastened tightly.
27. Paint the ball valve (20) and the flange (3) the same color as ship's body. Paint only gray-colored areas; for other parts, seal with masking tape. Remove the tape when the paint dries.

<How to open/close the ball valve>

To open/close the ball valve, attach the supplied handle to the square projection then change the stopper position.

1. Remove the fixing plate as shown figure below then pull the shaft assembly up.

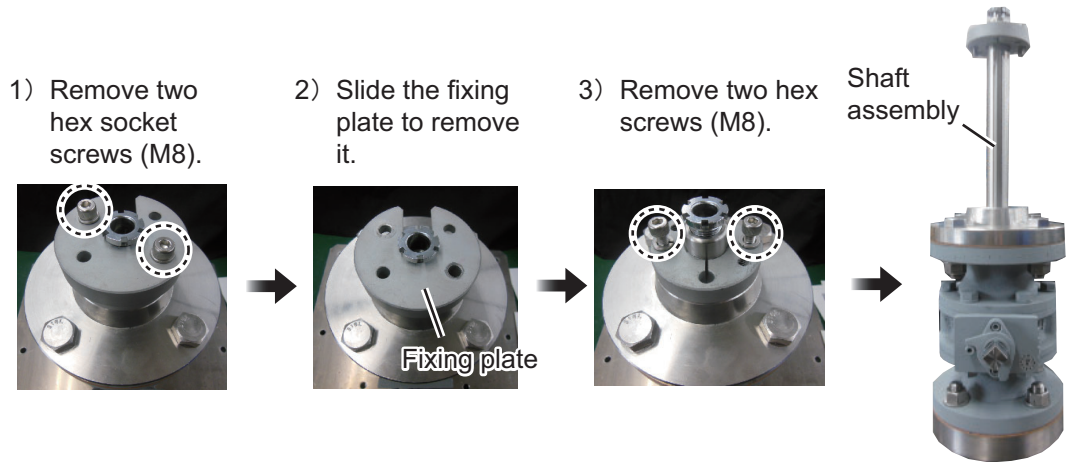

2. Attach the supplied handle to the square projection and then turn the handle 90° to change the stopper position.

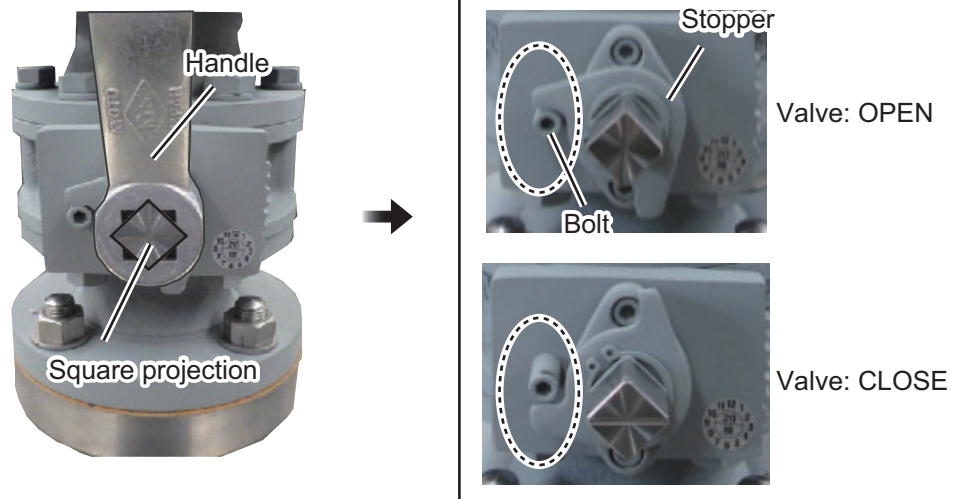

3. After opening or closing the ball valve, tighten the removed nuts until the handle cannot be turned. Also, remove four bolts (M16) to remove the shaft and the transducer assembly. After removing the assemblies, replace the gaskets as shown in the figure to the right.

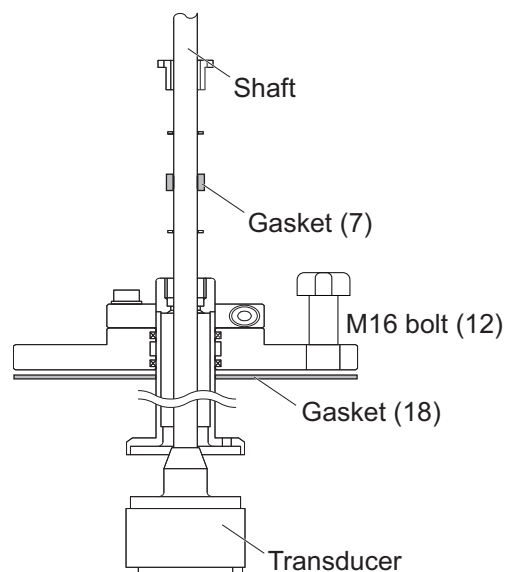

1.5 Option Unit

1.5.1 Junction Box

The junction box forms a joint between the distribution box and the transceiver unit.

Installation considerations

- Keep the junction box away from noise-emitting electrical machinery, for example, electric generator, radio transmitter, TV, etc.
- Although the box is splash proof, do not install it in places of high humidity.
- Avoid installing the box where temperature varies greatly, since moisture may penetrate the box.

Procedure

Open the box cover, and fix the unit to a bulkhead, referring to the outline drawing at the back of this manual.

1. Select a mounting location, referring to the recommendations listed above.
2. Remove the cover of the junction box.
3. Fix the junction box from inside with the supplied self-tapping screws (5×25).
4. Attach the cover again.

1.5.2 Range Selector

Change analog output to allow analog scales of -2 to 6 kn in addition to -10 to 30 kn.

Installation considerations

- The temperature and humidity of the mounting location should be moderate and stable.
- Avoid locations near the air intake, dusty storage or where water splashing.
- Mount the unit where shock and vibration are minimal.

1.5.3 Analog Display Unit

The analog display units show the ship speed in the clockwise direction (For SL-200-5 and SL-200-5W, the ship speed in the counterclockwise direction).

There are two types of range scales according to the model of the analog display unit; single scale and double scale.

For double scale display units, there are scales on the outside and the inside. You can switch the scale between the scale on the outside and the inside with the range selector MF-2R-1 / 2. If the range selector is not connected, only the outer scale is valid.

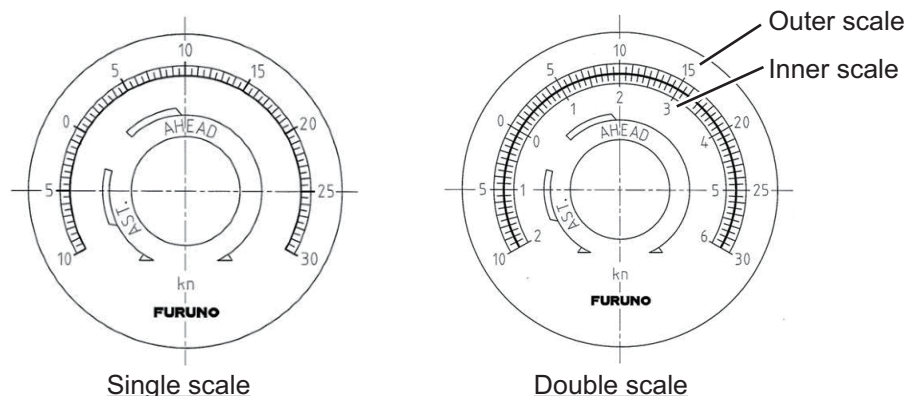

Installation considerations

The analog indicator is an ammeter. An error may occur if a strong magnetic field exists nearby. Keep away from transformers and power supplies as much as possible. Avoid places subject to rain or seawater splashes and high temperatures or where there is high humidity and vibration.

1.5.4 Remote Controller

For installation and cable connection of Remote Controller RD-501, see the operator's manual of the connected sub display (RD-20: OME-44540, RD-50: OME-44530) for your reference.

1.5.5 Dimmer Controller

The dimmer controller has two types as below.

DS-F25/S25/FE25/SE25

These are used for externally controlling the illumination of the analog indicator. These power supply specifications (100-115 VAC or 200-220 VAC) vary depending on the type used.

RD-502

The RD-502 is used for controlling the illumination of the display unit DS-8500 and the sub display unit (option).

For the connection between RD-502 and RD20/RD-50, refer to the operator's manual of each remote display (RD-20: OME-44540, RD-50: OME-44530).

1. MOUNTING

<Installation considerations>

- The nominal viewing distance for the remote display is 1 m. Select a suitable mounting location considering that distance.
- Locate the remote display away from exhaust pipes and vents.
- Select an installation location that is well ventilated.
- Locate the remote display where shock and vibration are minimal.
- Locate the remote display away from equipment which generates the electromagnetic fields like a motor or generator.
- Allow enough maintenance space at the sides and rear of the remote display and leave enough slack in cables to facilitate maintenance and servicing.
- Observe the compass safe distances (see page ii) to prevent interference to a magnetic compass.

<Procedure>

Only flush mounting is available.

Note: Make sure the cables are connected before installing the remote or dimmer controllers.

1. Make a cutout in the mounting location (88 mm (width) x 76 mm (height)).
2. Make four holes of $\phi 4$ in the locations indicated in the illustration below.
3. Set the remote controller or dimmer controller to the cutout. Insert four binding head screws (M3x12) from the front side then fasten the unit with four sets of flat washers, spring washers and hexagonal nuts from the rear side.

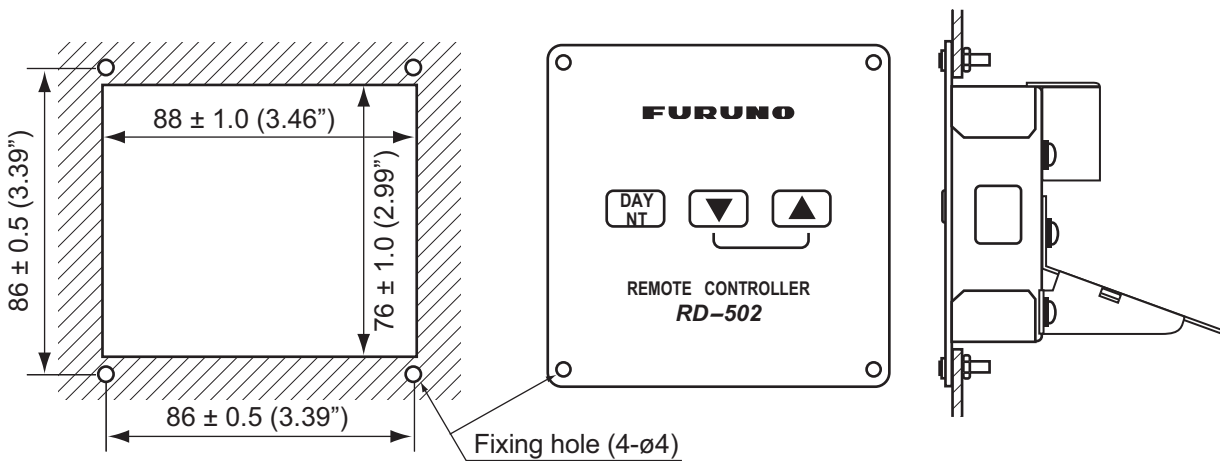

2. WIRING

2.1 Overview

Standard wiring

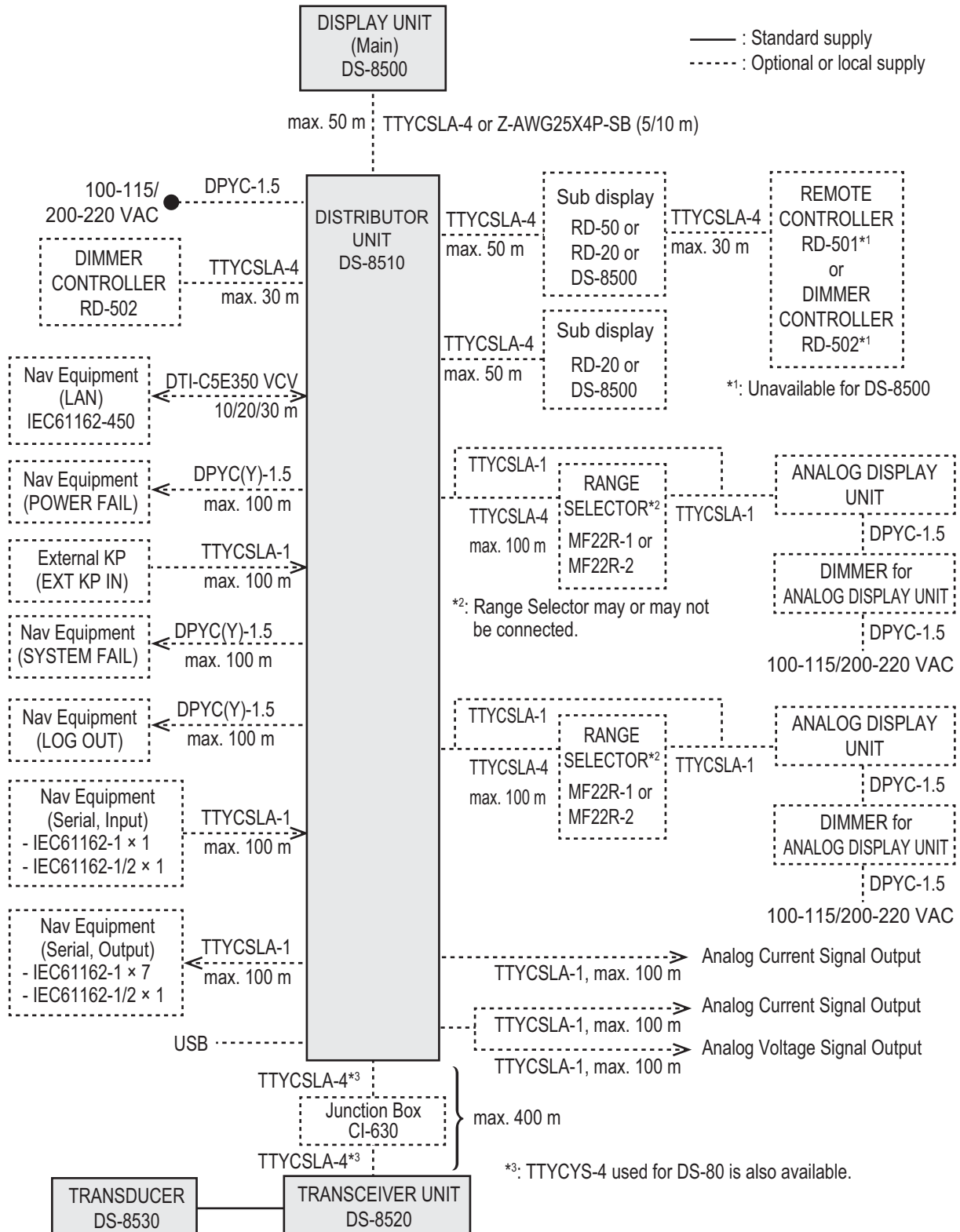

2.2 Precautions for Cable Installation

To avoid noise and interference, lay cables between units as far away as possible from power cables and radio transmission signal cables.

When the cables run in parallel with power cables, separate them 400 mm at minimum.

Run the transducer cables separate from other cables as much as possible.

Also, ground the equipment to prevent electrical shock and mutual interference.

2.2.1 WAGO connection

For the display unit, the terminal opener is included inside the cable clamp on the back cover.

For the distributor unit, the two terminal openers are included inside the unit. Check that the size (large or small) of the opener is correct before use.

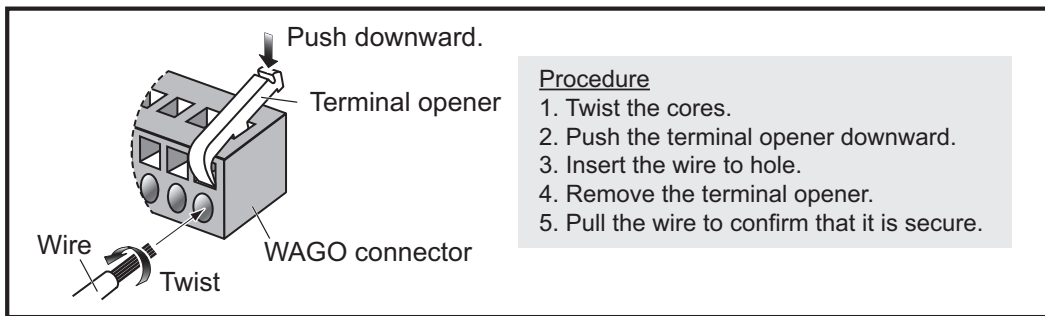

2.3 Display Unit

2.3.1 How to fabricate the cables

Using the supplied terminals on the inside of the DS-8500, fit the drain wire (or shield line) of each cable with a terminal, then attach the terminal to the inside of the DS-8500 (the same place it was situated originally).

TTYCSLA-4

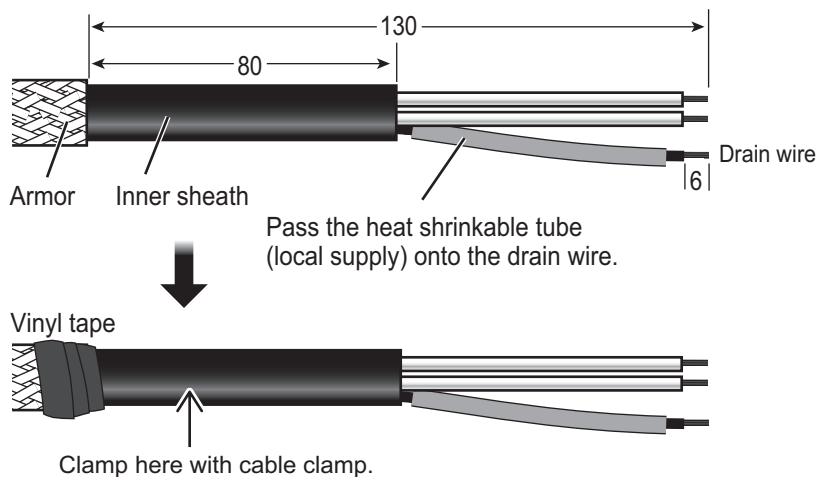

2.3.2 How to connect the cables

1. Unfasten the four screws on the rear cable clamp, then remove the cable clamp to reveal the WAGO connector.

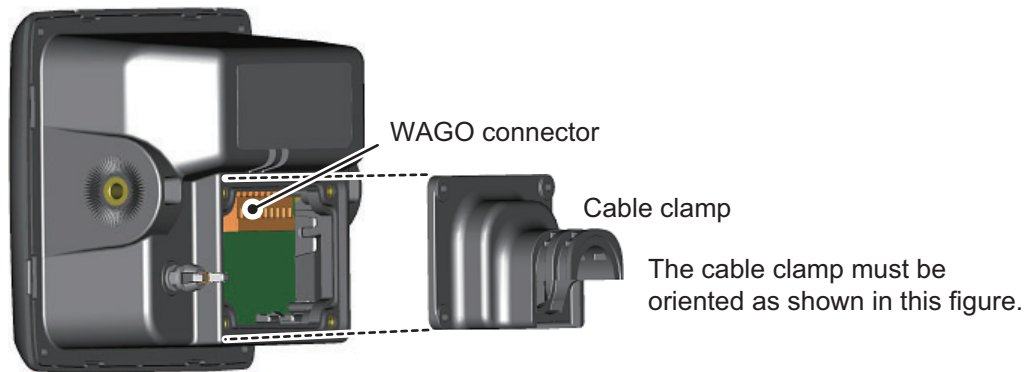

2. Unplug the WAGO connector from the display unit.
3. Pass the cable through the cable clamp.
Note: To maintain the IPx5 waterproof rating, the cable must be TTYCSLA-4 (or equivalent) with a diameter of $\phi 14.4 \pm 0.4$ mm.
4. Referring to the interconnection diagram at the back of this manual, connect the display unit using the WAGO connector inside the unit.
5. Reattach the WAGO connector to the display unit.
6. Slide the cable clamp along the cable towards the display unit, then fasten the four screws which were removed at step 1. The cable clamp must be oriented as shown the figure above.
7. Secure the cable to the cable clamp with cable tie(s) (included). The location and number of cable tie(s) is different, depending on whether the cable assembly OP05-146-1, OP05-146-2, optional cable protection kit or waterproofing kit is installed. Refer to the figure below for the correct location and numbers.

Top view of cable clamp

When using the cable assembly OP05-146-1, OP05-146-2 or the cable protection kit (OP05-147)	When using the cable (TTYCSLA-4)	
	Without using the waterproofing kit (OP05-139)	With using the waterproofing kit (OP05-139)
With three cable ties	With two cable ties	With a single cable tie
<p>Cable clamp</p> <p>Cable tie</p> <p>Cable gasket</p> <p>Secure the cable gasket also with a cable tie.</p>	<p>Cable clamp</p> <p>Cable tie</p> <p>Slot</p> <p>Wind cable ties through the slots.</p>	<p>Cable clamp</p> <p>Cable tie</p> <p>Slot</p> <p>Cable gasket</p> <p>Wind a cable tie outside of the cable clamp.</p>

In cases where the WAGO connector is connected to the cable before the cable is passed through the cable clamp, the cable clamp can be adjusted to allow connection.

How to fit the optional waterproofing kit (OP05-139)

The optional waterproofing kit must be fitted at the same time as the cabling is connected to the display unit.

2. WIRING

Note: To satisfy the requirements for IPX5 waterproof rating, the cable used must have a diameter of 14.4 mm (± 0.4 mm).

1. Unfasten the four screws on the rear cable clamp, then remove the cable clamp to reveal the WAGO connector.
2. Fit the cable gasket to the cable clamp, referring to the figure below.

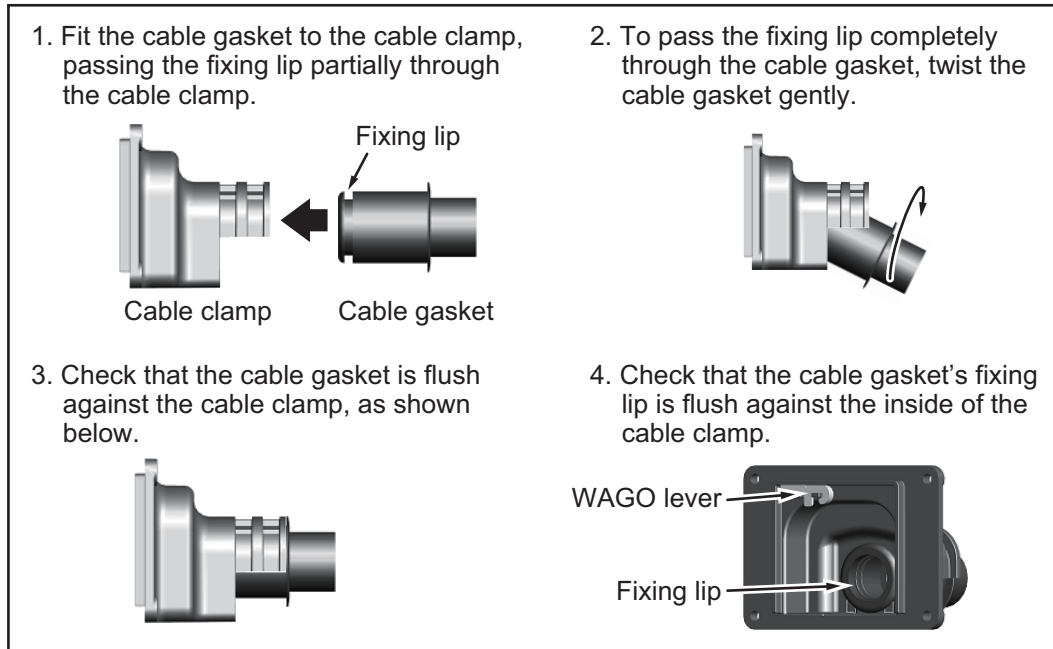

3. Pass the cabling through the cable gasket and cable clamp.
4. Fit the cover gasket (rubber seal) to the rear of the display unit. Make sure the rubber seal is placed inside the groove indicated in the figure below.

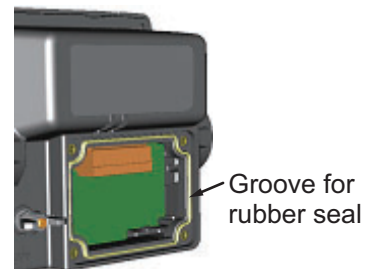

5. Connect the cabling to the display unit, referring to the interconnection diagram at the back of this manual.
6. Slide the cable clamp along the cable until the clamp is flush against the rear of the display unit.
Note: The cable clamp must be oriented with the dome facing upwards in order to retain its waterproofing rating.
7. Fasten the four screws removed at step 1.
8. Secure the cables to the cable clamp with cable ties.

2.4 Distributor Unit

2.4.1 Required tools

The following item should be prepared in advance for this installation locally.

Item	Qty	Remarks
Cable tie	61	Equivalent of Convex CV-150B (125 × 4.9 mm)

2.4.2 How to fabricate the cables

Note: Make sure that the cover does not contact any connected cables when you close the cover.

TTYCSLA-4/-1 DPYC(Y)-1.5 for Navigation equipment and display unit. transceiver unit

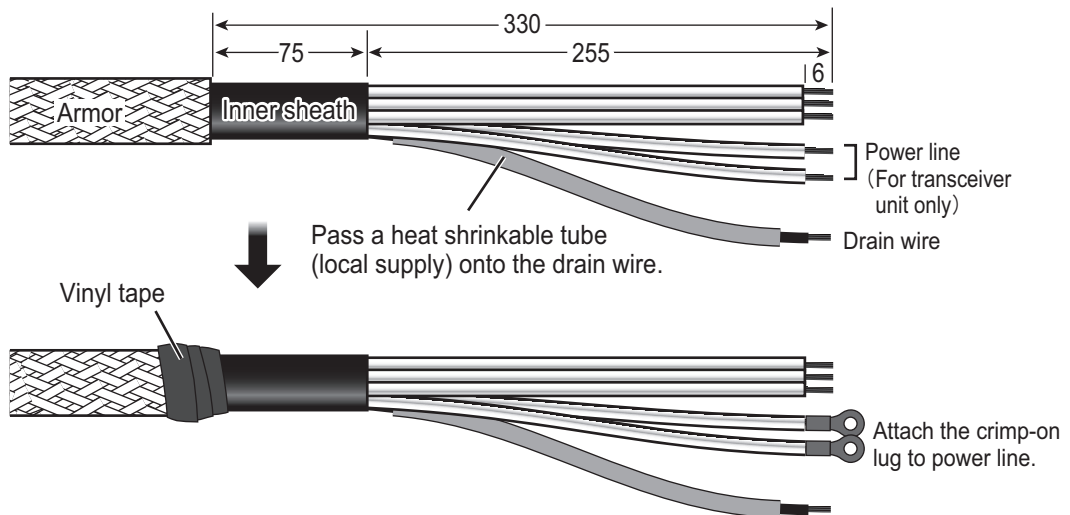

TTYCY-4S for transceiver unit (used with DS-80)

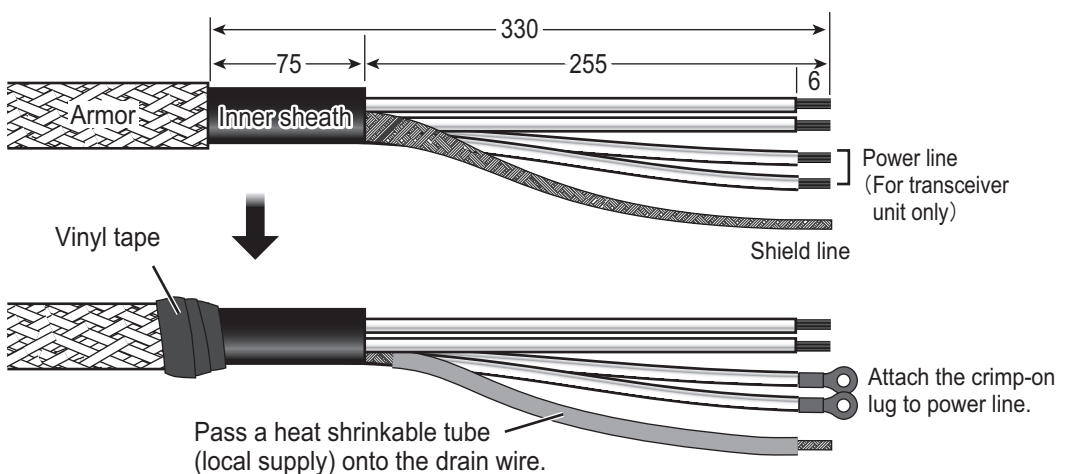

DPYC(Y)-1.5 for Ship's Mains

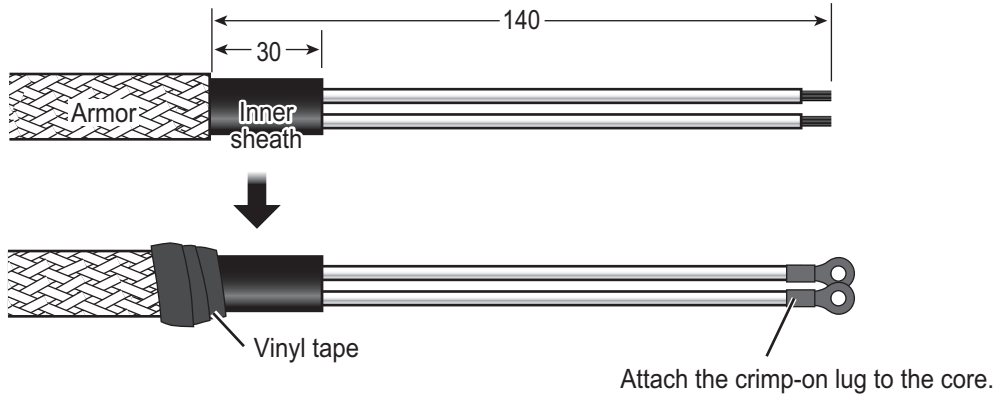

LAN cable DTI-C5E350 VCV

Note: This equipment only uses straight cables.

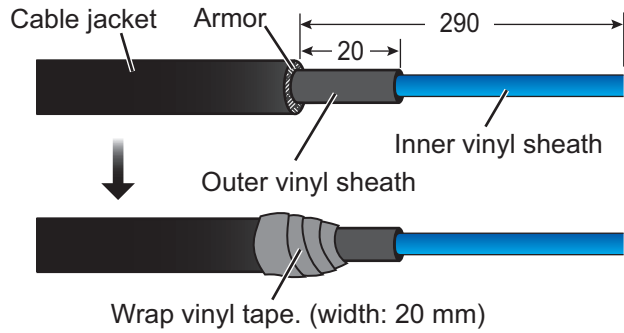

Expose inner vinyl sheath.

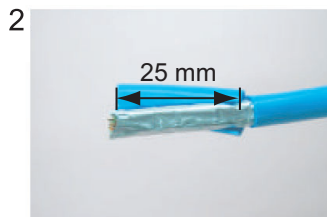

Remove the inner vinyl sheath by approx. 25 mm. Be careful not to damage inner shield and cores.

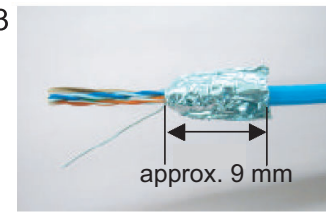

Fold back the shield, wrap it onto the inner vinyl sheath and cut it, leaving approx. 9 mm.

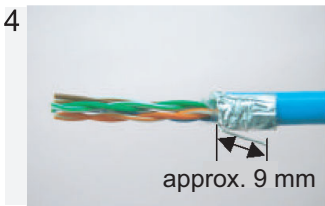

Fold back drain wire and cut it, leaving approx. 9 mm.

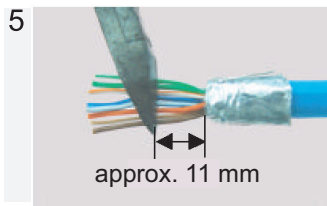

Straighten and flatten the cores in colored order and cut them, leaving approx. 11 mm.

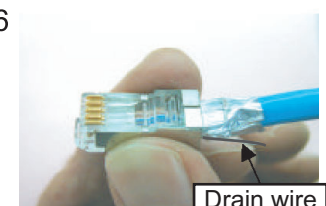

Insert the cable into the modular plug so that the folded part of the shield enters into the plug housing. The drain wire should be located on the tab side of the jack.



Using special crimping tool MPT5-8AS (PANDUIT CORP.), crimp the modular plug. Finally, check the plug visually.

Modular plug

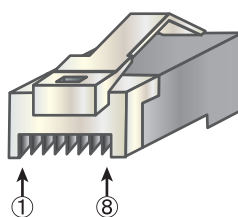

[Straight cable]

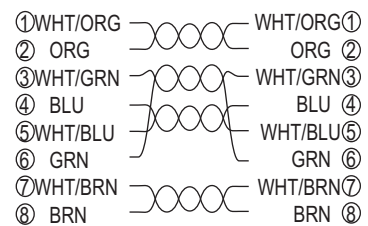

2.4.3 How to connect the cables

Some parts or wiring have been omitted from the illustrations for clarity.

Note: When closing the distributor unit, make sure that the connected cables do not contact the cover.

How to open/close the top cover

Unfasten nine screws to open the top cover.

After the appropriate cable connections are completed, fasten nine screws to close the top cover.

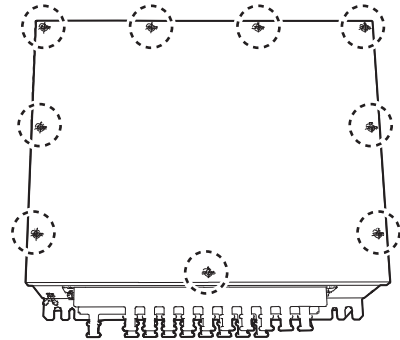

Cable entrance

There are two layers at the cable entrance on the front side of the distributor unit, upper and lower entrances.

First, loosen two screws to remove the upper protector. The upper cable entrance appears. Then, loosen two screws to remove the lower protector. The lower cable entrance appears.

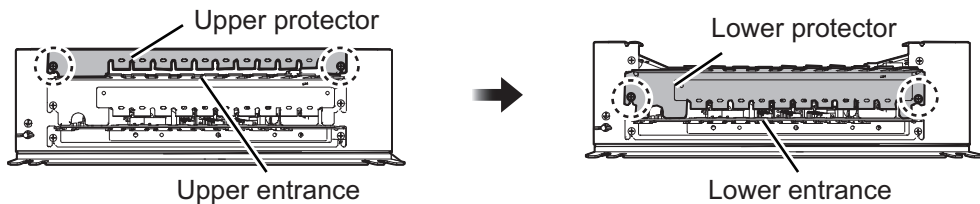

Set each cable on the cable entrance, referring to "Cable entrance" on page 2-8 then fasten the cable as follows with two cable ties which are supplied locally.

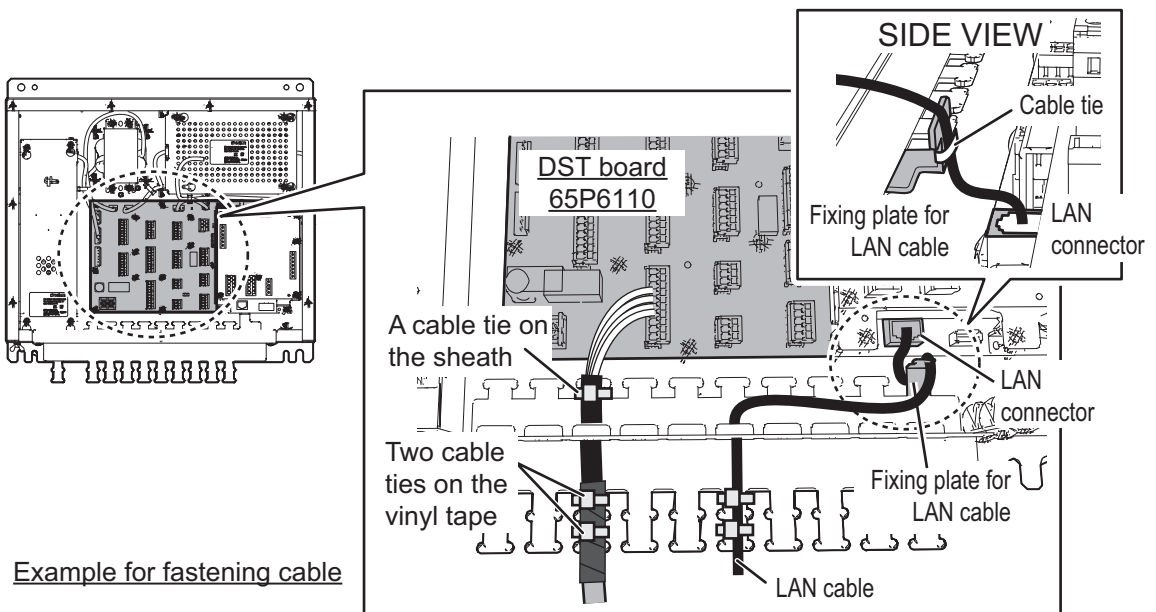

Note: If the cable is too thick for the protector to hold, bend the protector with a plier supplied locally.

2. WIRING

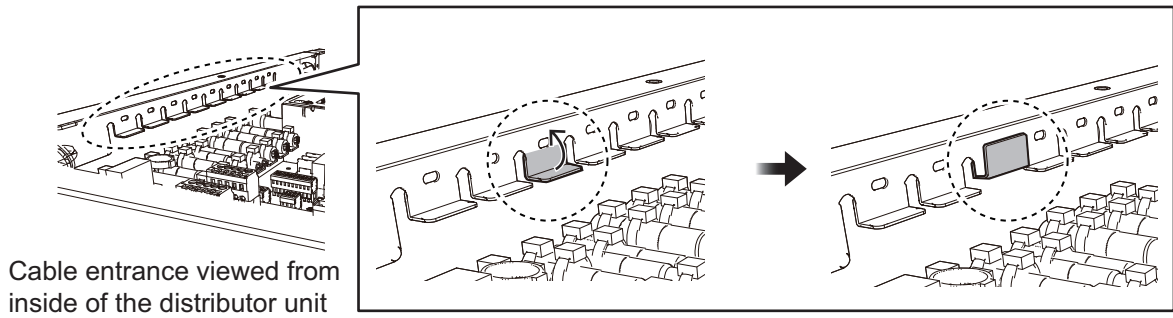

Also, the lane for each cable is shown below, referring to the Wiring Label attached on the reverse side of the top cover.

Cable connection (other than the power cable)

Connect the cables to the connectors on the DST board 65P6110 and the LIF board 65P6111 (option). The core lines of the cables should be connected to the connectors referring to the interconnection diagram at the back of this manual.

The type of cable to be connected and the cable location on the cable entrance are shown in the following figure and table.

The LIF board

Cable entrance

For a thick cable, bend the protector with a plier.

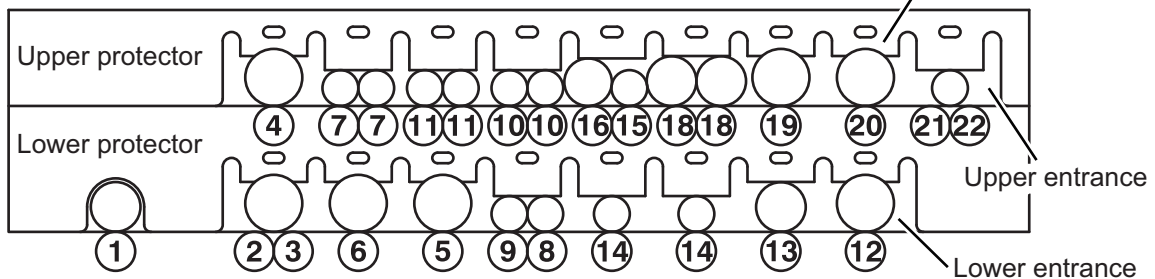

DST board 65P6110

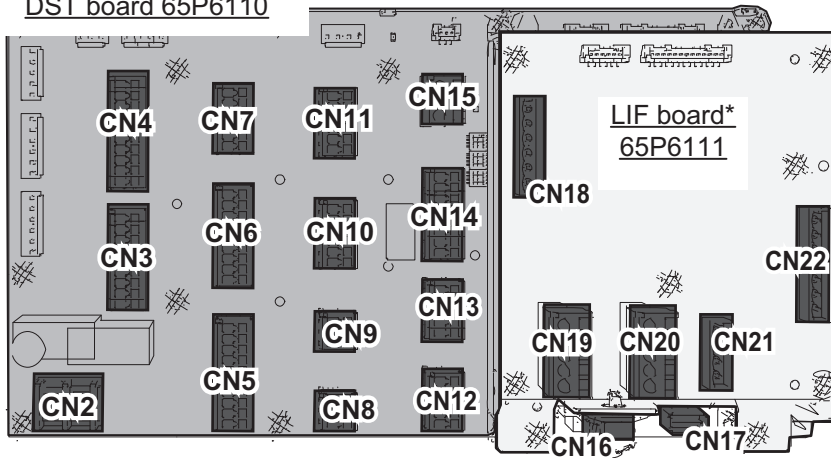

*: If LIF board is not attached in distributor unit, the board is provided with the optional kit OP65-3.

Connector location

No. of cable entrance	Signal	Printed board		Remarks
		Type	Connector no.	
2	TRX POWER	65P6110 (DST)	CN2	Power to transceiver unit
3	TRX		CN3	Signal from transceiver unit
4	SUB DISP1		CN4	
5	DISP		CN5	
6	SUB DISP2		CN6	
7	IEC61162OUT3		CN7	
8	IEC61162IN1		CN8	
9	IEC61162IN2		CN9	
10	IEC61162OUT1		CN10	
11	IEC61162OUT4		CN11	
12	DIMMER		CN12	
13	POWER FAIL		CN13	
14	IEC61162OUT2		CN14	
15	EXT KP IN		CN15	
16	LAN		CN16	
—	USB		CN17	
18	SYSTEM FAIL		65P6111 (LIF)	CN18
19	ANA DISP1	CN19		
20	ANA DISP2	CN20		
21	ANA DISP3	CN21		
22	ANA DISP4	CN22		

Connection of power cable

Remove the four screws on the cable cover inside the distributor unit. Set the power cable from ship's Mains on the no.1 cable entrance, referring to the "Cable entrance" on page 2-8 and fasten the cable with two cable ties supplied locally. The core should be connected to CN1 terminal as follows.

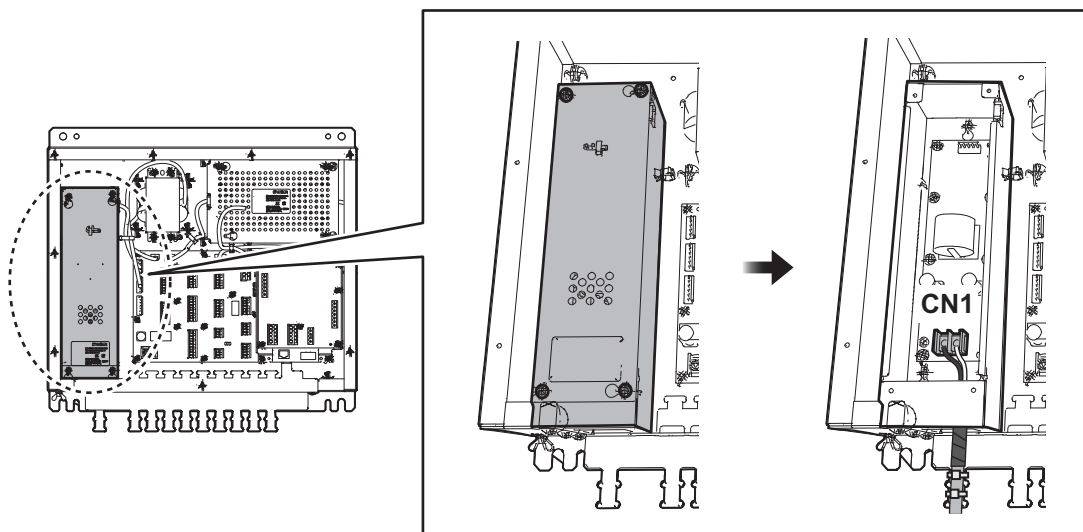

2.5 Transceiver Unit

2.5.1 How to fabricate the cables

Attach the SC lock and the packing (pre-attached to the cable entry on the transceiver) to the cable before fabricating the cable. Please pay attention to the orientation of the SC lock and packing.

Signal cable

The cables listed in the table below can be used for the transceiver unit.

Depending on the used cable, the type of the SC lock and the fixing location on the cable are various, referring to the table below. The appropriate SC lock must be attached at the appropriate location on the cable.

Type of cable	Replacement to OP65-4	Fixing location on the cable	Remarks
TTYCYSLA-4	—	On the outer sheath	
TTYCSLA-4	Required	On the armor	No outer sheath
• TTYCY-4S • TTYC-4S	—	On the inner sheath	Cable for DS-80
Other cable φ14.5 to 16.5?	Required		

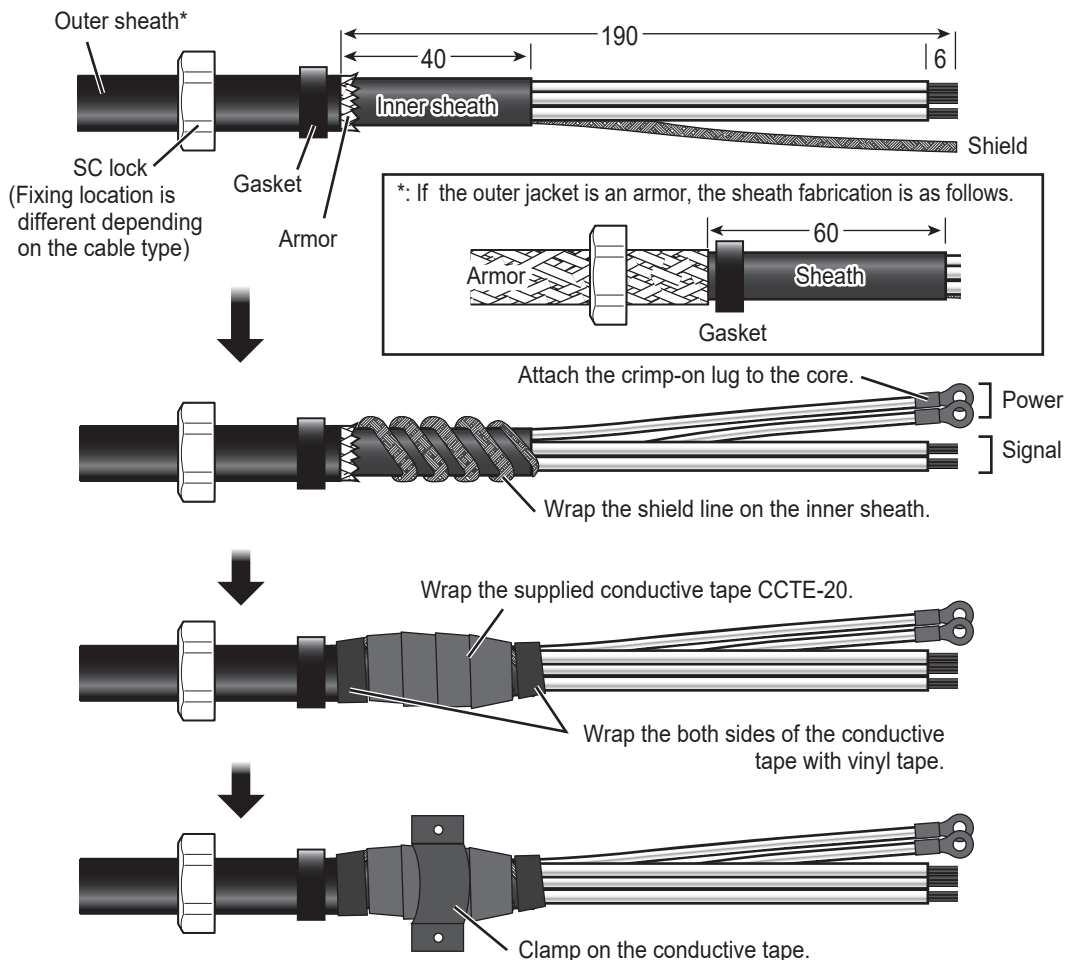

When using the optional junction box, fabricate the cable as in the previous figures.

Transducer cable

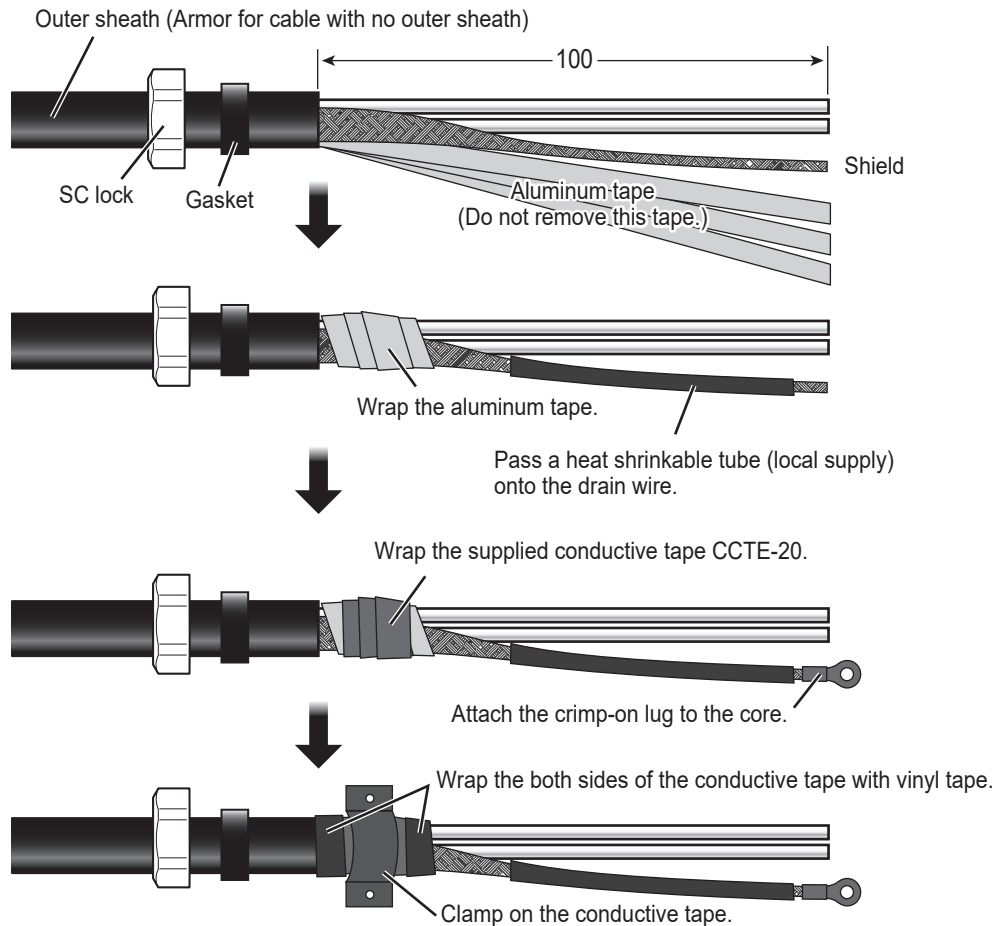

2.5.2 How to connect the cables

How to open/close the top cover

Unfasten seven screws to open the top cover.

After the appropriate cable connections are completed, fasten seven screws to close the top cover.

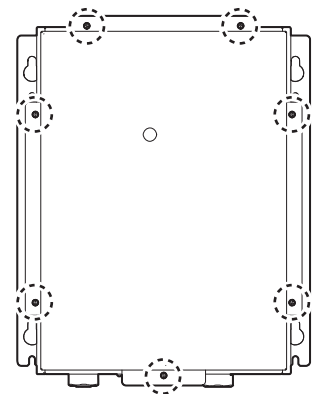

Cable Connection

Connect the signal cable and the transducer cable from the distributor unit as shown below. Refer to the interconnection diagram at the back of this manual for connection details.

2. WIRING

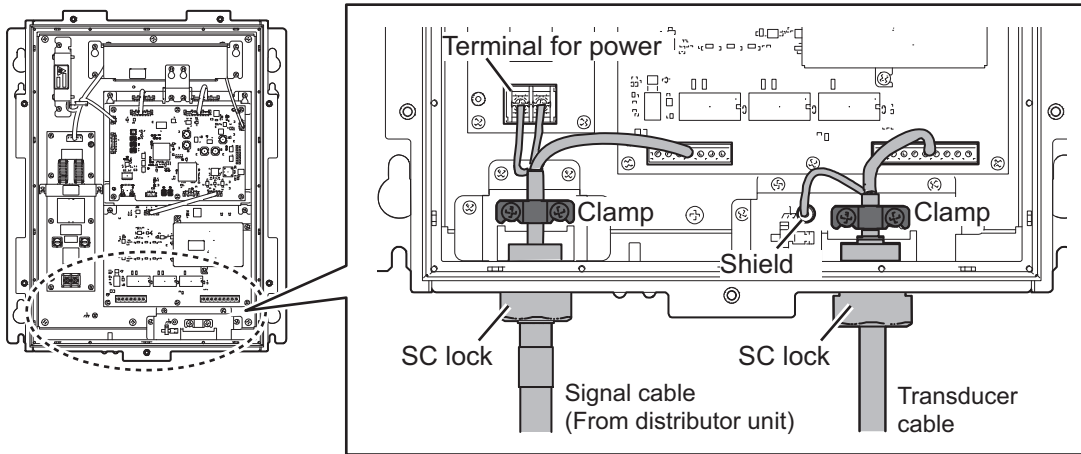

- Signal cable (from distributor unit): Connect the power and signal lines, and fix the cable on the conductive tape with the clamp in the transceiver unit. Then tighten the cable with the SC lock.
- Transducer cable: Connect the signal and shield lines, and fix the cable on the conductive tape with the clamp in the transceiver unit. Then tighten the cable with the SC lock.

2.6 Junction Box (option)

The transducer cable is connected to the junction box with an extension cable. After making the connection, seal the cable gland with putty for watertightness.

2.6.1 How to fabricate the cable

Before cable fabrication, attach the cable glands and gaskets which are attached at the cable entrance on the cable in advance. Please pay attention to the orientation of cable glands and gaskets on the cable.

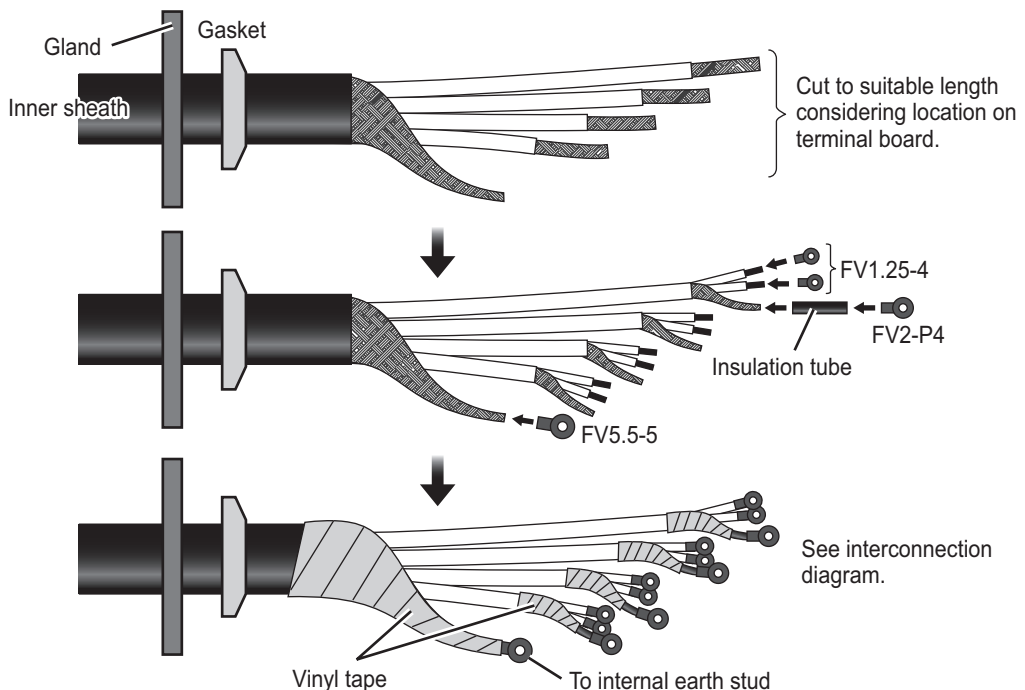

After tightening the inner sheath by the gland, wind a grounding wire on the armor as shown below. Then connect the grounding wire to the wing nut on the front of the chassis.

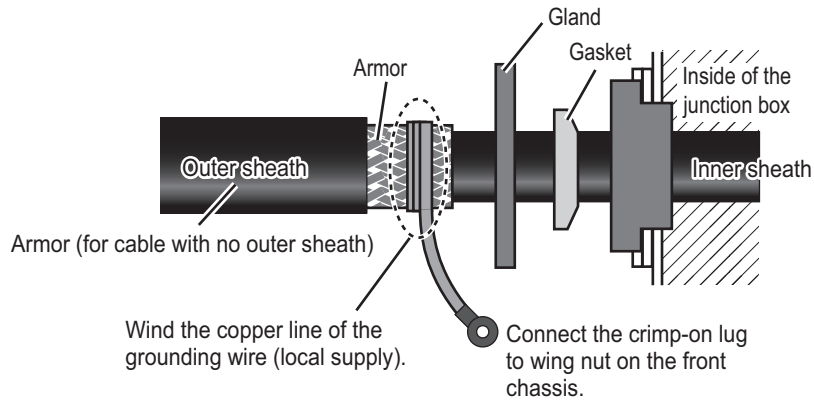

2.6.2 How to connect the cables

For the cable connection details, see the interconnection diagram at the back of this manual. After cable connection, seal the gland with putty for watertightness as shown below.

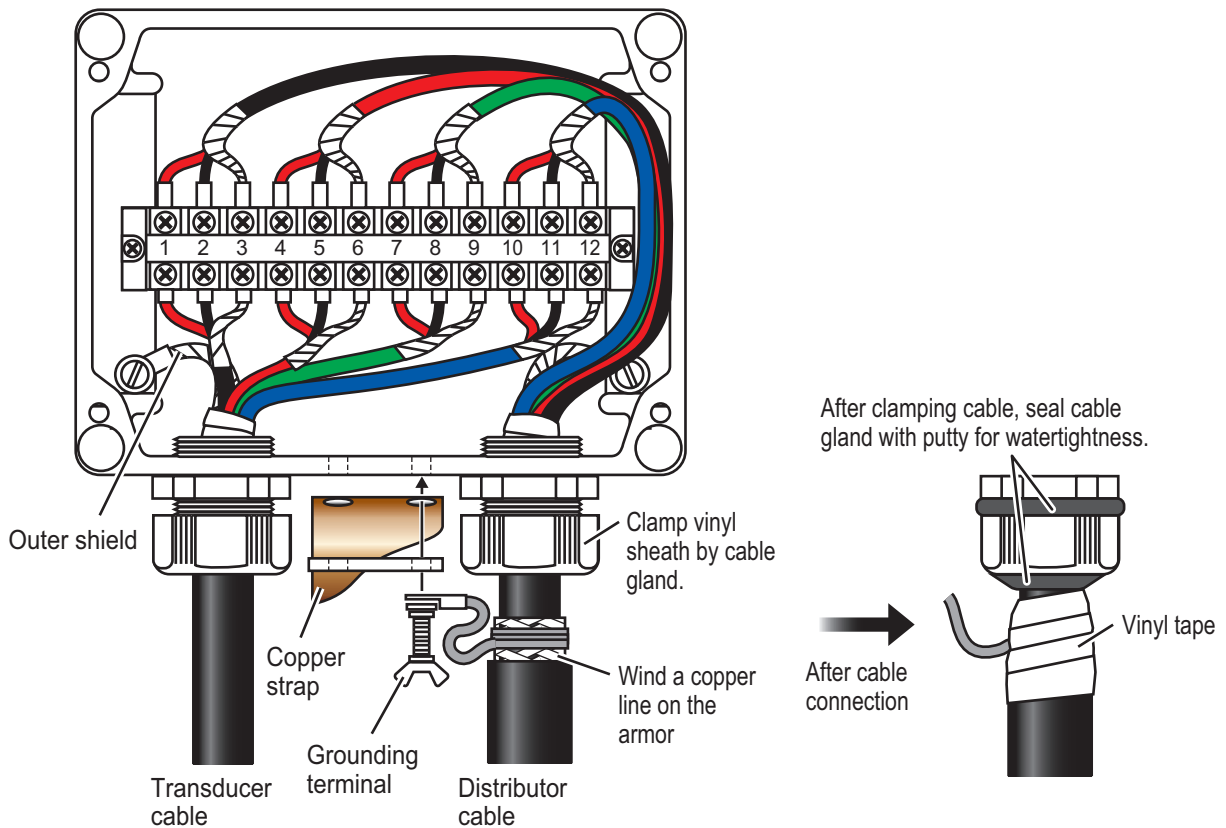

2.7 Grounding

This equipment uses pulse signals which may cause interference to other electronic equipments It is strongly recommended to ground all cables referring to the guidelines below.

- Separate all units as far as possible from radio equipment.
- Do not run interconnection cables close to or near radio equipment or its cables.
- Run the cables in the shortest practical path.
- Ground all units with a copper strap or earth wire.
- To join copper straps, use solder cream for perfect contact.

3. ADJUSTMENTS

At the first start-up after installation, turn on the display unit with the power key. Open the protected menus to adjust the system. Follow the procedures in this chapter to complete the adjustment.



Power key

Transducer initial setting

For the main display unit, the [XDCR INIT SET] display is shown when the power is turned on. After the above settings are completed, select [END] with the ▼ key and then press the **ENT** key. The confirmation message "ARE YOU SURE? (RESTART OK?)" is shown, and select [YES] then press the **ENT** key to complete the initial settings.

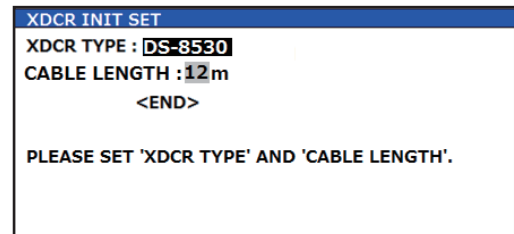

Once set the following items, this window is not shown at start up next time. To change the following settings, initialize this setting at the [TYPE CLEAR] menu (see page 3-4).

- [XDCR TYPE]: Set the type of the transducer, [DS-820] or [DS-8530] (default setting: [N/A]).
Note: If an incorrect setting is entered, STW (Speed Thru Water) is not displayed correctly and the transducer may overheat, causing malfunction.
- [CABLE LENGTH]: Set the transducer cable length 1 to 40 m (default setting: 20 m)
Note: Set the correct cable length to compensate for the correction of the transducer signal with cable length. If an incorrect setting is entered, the STW (Speed Thru Water) is not displayed correctly.

Display unit initial setting

For installations with a single DS-85, select [MAIN]. For vessels with more than one DS-85, you can share the brilliance setting across the networked DS-85s. Select [MAIN] for the main DS-85 unit, SUB units receive and use the setting from the MAIN unit. To show the **UNIT SET** window, press the **MENU** → **DISP** → **BRILL** keys in order during the start-up window below is shown. After selecting [MAIN] or [SUB], select [END] with the ▼ key and then press the **ENT** key. The confirmation message "ARE YOU SURE? (RESTART OK?)" is shown then select [YES] and press the **ENT** key.

3. ADJUSTMENTS

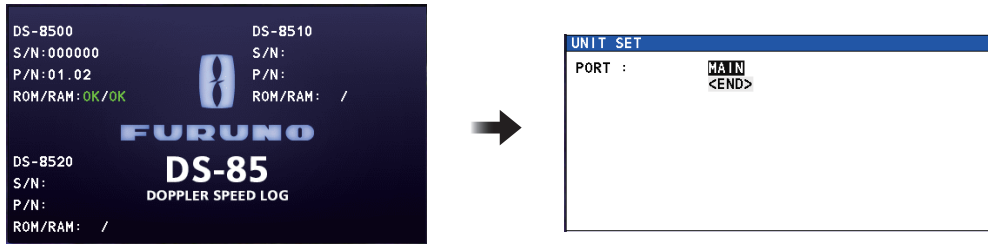

[MENU]→[DISP]→[BRILL] key

How to select the language for menu window

The default language for the menu window is English. To change the language to Japanese, set as follows.

1. Press the **MENU/ESC** key to open the main menu.

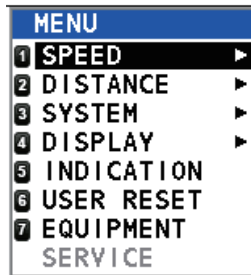

2. Select [DISPLAY] then press the **ENT** key.

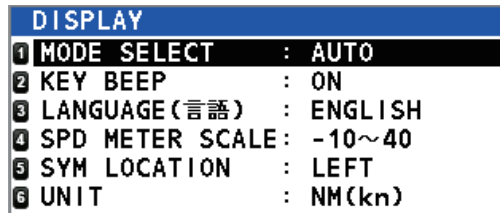

3. Select [LANGUAGE] then press the **ENT** key.
4. Select the appropriate language (English or Japanese) then **ENT** key.
5. Press the **DISP** key to close the menu window.

How to Open the [EQUIPMENT] menu for installation

Note: For “MAIN” display unit only, the installation menus are operative. Make sure that [M] (Main) is shown at the top of display.

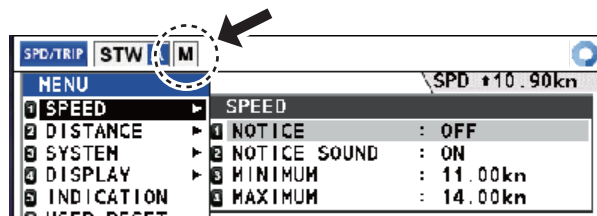

1. Press the **Power** key to turn on the unit.
2. Press the **MENU/ESC** key to open the main menu. The [SERVICE] menu is shown in grey and inoperative.
3. Select [EQUIPMENT] then the password input window for the [EQUIPMENT] menu is shown.

- Enter the password (**ENT** key × 6 times) to open the sub menu. The [EQUIPMENT] menu has the eight sub menus shown in the figure below.

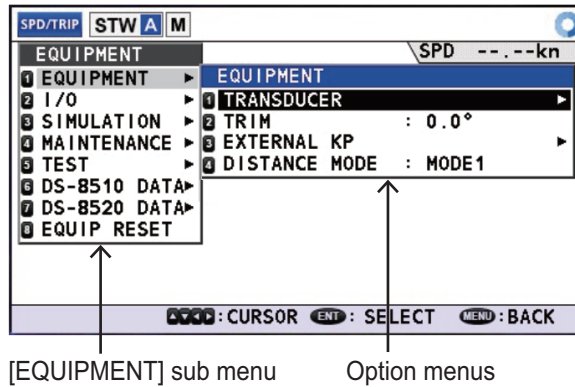

- Close the menu by pressing the **MENU/ESC** key once or click the left button a few times.

Status bar

The status bar is shown on every screen, and gives you a quick, at-a-glance view of the DS-85's current status. See the Operator's Manual (OME-72880) for this equipment. The two icons for service man are shown below.

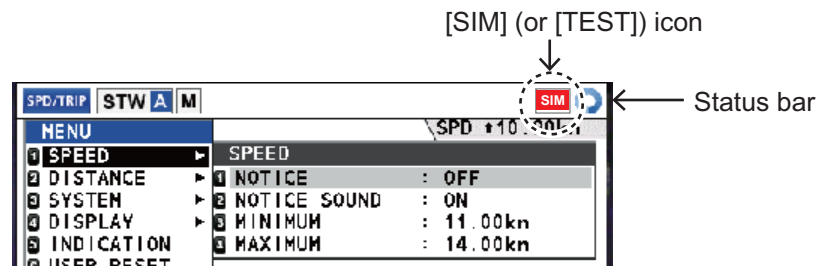

- [SIM] icon: Displays when the simulation mode is active (see section 3.3).
- [TEST] icon: Normal operation cannot be performed when the [TEST] icon is displayed. To return to normal operation, change the DIP switch settings as follows.

Unit	Printed Board	DIP switch	Setting
Distributor Unit	DST board 65P6110	SW3	OFF (all)
Transceiver Unit	MAIN board 65P6120	SW2	OFF (all)

3.1 [EQUIPMENT] sub menu

On the main menu, select [EQUIPMENT] → [EQUIPMENT] to open the [EQUIPMENT] sub menu.

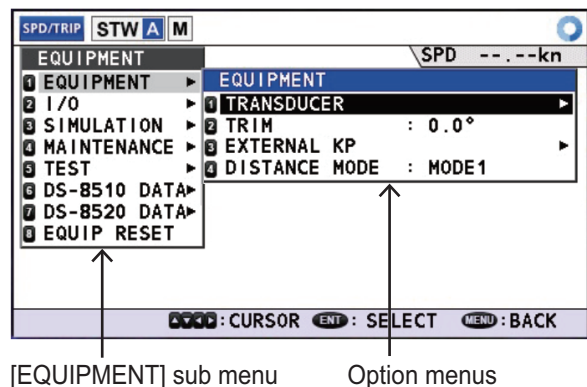

3. ADJUSTMENTS

3.1.1 [TRANSDUCER] menu

On the [EQUIPMENT] sub menu, select [TRANSDUCER] to open the [TRANSDUCER] menu.

EQUIPMENT	
TRANSDUCER	
TYPE	: DS-8530
2 TYPE CLEAR	
3 OFFSET	: 0°
4 CABLE LENGTH	: 10m
5 XDCR POSITION	

[TYPE]

Shows the type for the transducer which is set the transducer initial setting. See page 3-1 for the transducer initial setting.

To change the type, execute [TYPE CLEAR] then set the transducer settings again.

[TYPE CLEAR]

Select [YES] on the confirmation message to reset the default settings for the setup of the transducer.

[OFFSET]

If the transducer is not installed parallel to the bow-stern keel line, correct the error in the equipment angle. Set the calibration angle for the transducer position (default: 0°). The setting range is -135° to -180°, -45° to 45° and 135° to 180. Set the clockwise direction as + with viewing the transducer from above.

EQUIPMENT		SPD	-- --kn
1 EQUIPMENT	▶	EQUIPMENT	
2 I/O	▶	TRANSDUCER	
3 SIMULATION	▶	TYPE : DS-8530	
4 MAINTENANCE	▶	2 TYPE CLEAR	
5 TEST	▶	3 OFFSET : 0°	
6 DS-8		▲000°	
7 DS-8		▼	
8 EQUI		[-135°, -180°] [-45°, 45°] [135°, 180°]	

[CABLE LENGTH]

Shows the cable length of the transducer which is set at initial setting. See page 3-1 for the transducer initial setting. Make sure that the length is correct for calibration by the temperature sensor.

To change the cable length, execute [TYPE CLEAR] then set the transducer settings again. see page 3-4 for [TYPE CLEAR].

EQUIPMENT		SPD	-- --kn
1 EQUIPMENT	▶	EQUIPMENT	
2 I/O	▶	TRANSDUCER	
3 SIMULATION	▶	TYPE : DS-8530	
4 MAINTENANCE	▶	2 TYPE CLEAR	
5 TEST	▶	3 OFFSET : 0°	
6 DS-8510 DATA	▶	4 CABLE LENGTH : 10m	
7 DS-8520 DATA	▶	5 XDCR POSITION	
8 EQUIP RESET		▲10m	
		▼	
		[1m, 40m]	

[XDCR POSITION]

Open the [XDCR POSITION] window to set the position for each transducer. The setting range for the number of the transducer is [01] to [99] (default: [01]).

For each transducer, set the X-axis distance (between port (-) and starboard (+) from the center of ship) and Y-axis distance (between bow and stern).

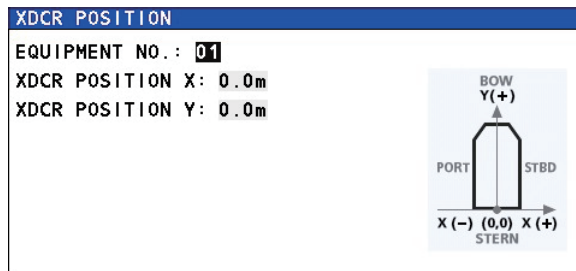

3.1.2 [TRIM] menu

On the [EQUIPMENT] sub menu, select [TRIM] to set the correction for ship angle.

The setting range is -12.5° to 12.5° (default: 0°).

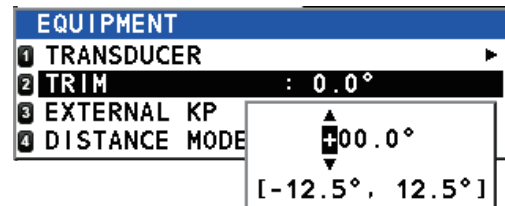

3.1.3 [EXTERNAL KP] menu

On the [EQUIPMENT] sub menu, select [EXTERNAL KP] to set up external KP.

[CONNECTION]

Select [CONNECT] when an external KP is connected, if not [DISCONNECT].

[XDCR DISTANCE]

Set the distance between the transducers that are connected to the external KP. This setting automatically adjusts the delay time for signal processing, based on the set distance. The setting range is 0 to 250 m (default: 0 m).

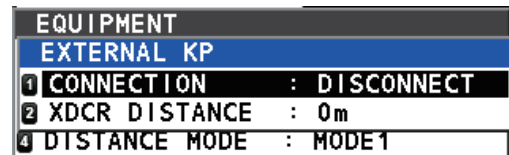

3.1.4 [DISTANCE MODE] menu

On the [EQUIPMENT] sub menu, select [DISTANCE MODE].

Select the speed calculation mode to use when normal speed calculation is not available.

- [MODE1]: Distance is **NOT** added, pulse is **NOT** output (default).
- [MODE2]: Distance is added, pulse is output, using the ship's last calculated speed.

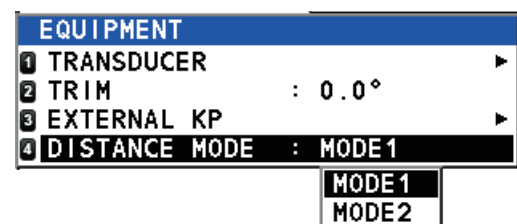

3.2 [I/O] sub menu

On the main menu, select [EQUIPMENT] → [I/O] to open the [I/O] sub menu.

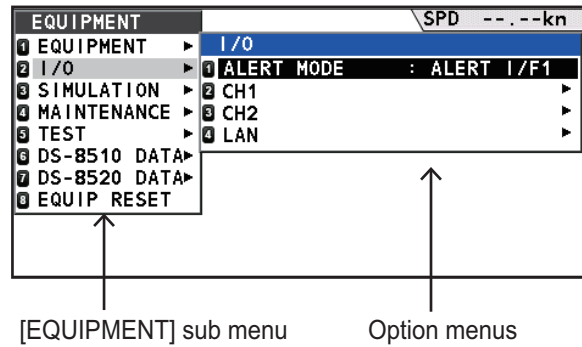

3.2.1 [ALERT MODE] menu

On the [I/O] sub menu, select [ALERT MODE] to set the alert mode, [LEGACY], [ALERT I/F1], [ALERT I/F2] and [ALERT I/F3] (default: [ALERT I/F1]).

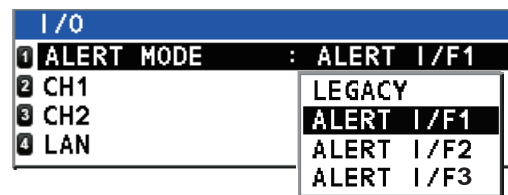

3.2.2 [CH1], [CH2] menu

On the [I/O] sub menu, select [CH1] (or [CH2]) to set each channel setting. These channels can be set for the following signals.

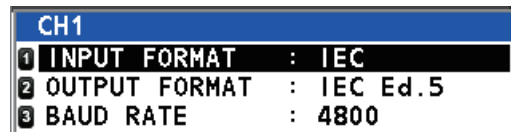

[CH1]: RD1, TD1

[CH2]: RD2, TD2 to TD8

[INPUT FORMAT]

Select the input format, [IEC] or [NMEA] (default: [IEC]).

[OUTPUT FORMAT]

Select the output format, [IEC Ed.1] to [IEC Ed.5] (default: [IEC Ed.5]).

[BAUD RATE]

Select the baud rate, [4800] bps or [38400] bps (default: [4800] bps).

Note: For [CH2], baud rate is fixed at [4800].

3.2.3 [LAN] menu

On the [I/O] sub menu, select [LAN] to set LAN setting.



[FORMAT]

Select the format for LAN connection, [IEC Ed.4] or [IEC Ed.5] (default: [IEC Ed.5]).

[TRANSMISSION GROUP SETUP]

Open the [TRANSMISSION GROUP SETUP] window to set the IP address or port.

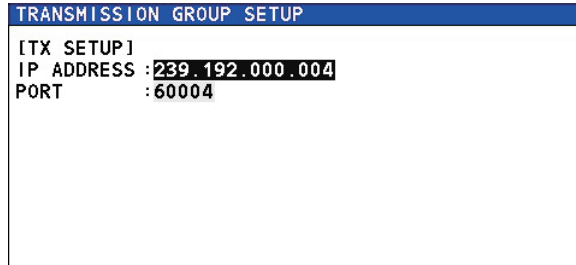

[IP ADDRESS]: Set the IP address, [000.000.000.000] to [255.255.255.255] (default: [239.192.000.004]).

[PORT]: Set the port, [00000] to [65535] (default: [60004]).

Note: To comply with the IEC standards, the following conditions are required.

- [IP ADDRESS]: Set between [239.192.000.001] and [239.192.000.064].
- [PORT]: Set between [60001] and [60064]

3.3 [SIMULATION] sub menu

The simulation mode displays and outputs internally specified speed data. This mode can be used for simulation and to check output to external equipment. "SIM" appears on the screen when the simulation mode is active.

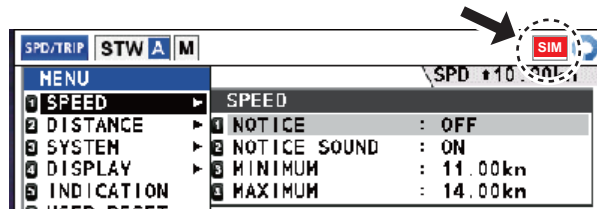

On the main menu, select [EQUIPMENT] → [SIMULATION] to open the [SIMULATION] sub menu.

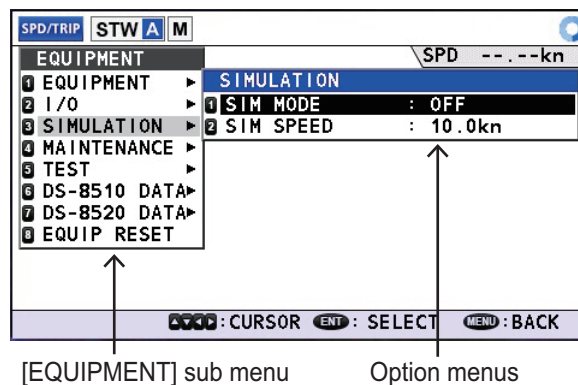

3. ADJUSTMENTS

SIM MODE

Select [ON] to activate the simulation mode.

SIM SPEED

Select the speed to output from the transceiver unit in simulation mode. The setting range is [-10.0] to [40.0] kn (default: [+10.0] kn).

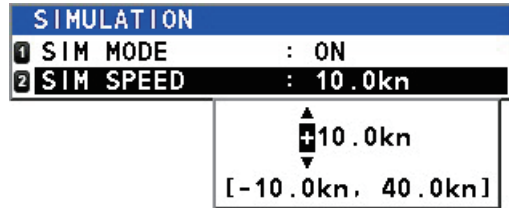

3.4 [MAINTENANCE] sub menu

On the main menu, select [EQUIPMENT] → [MAINTENANCE] to open the [MAINTENANCE] sub menu.

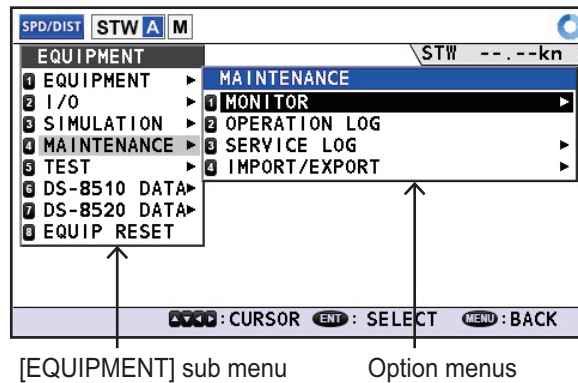

3.4.1 [MONITOR] menu

On the [MAINTENANCE] sub menu, select [MONITOR] to check the error status.

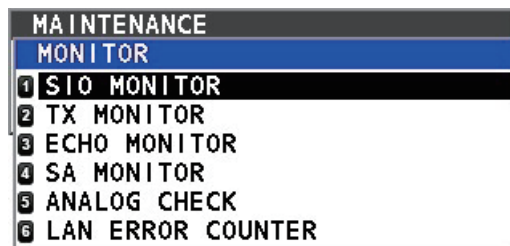

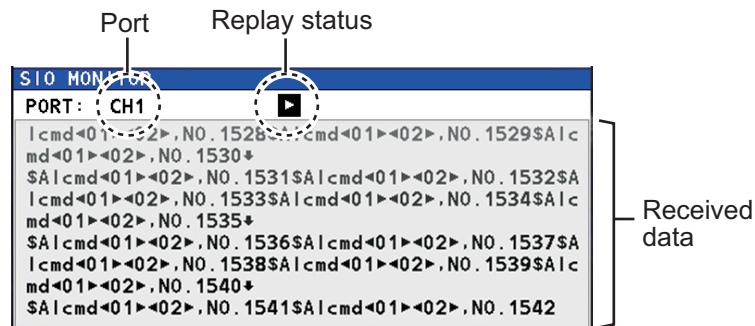

[SIO MONITOR]

Show the input port/data from an external equipment to DS-85.



Note: The input data is shown in just one screen and it is not updated automatically.





- [Port]: Select the input port ([CH1] or [CH2]) when the replay status is "PAUSE".
- Replay status:  means "PLAY",  means "PAUSE"
- Received data: Shows the input data from the start in one screen. The latest data is shown the last row. If the data is full in one screen, the replay status becomes "PAUSE". Set the status to "PLAY" after "PAUSE", shows the data in one screen again.

[TX MONITOR]

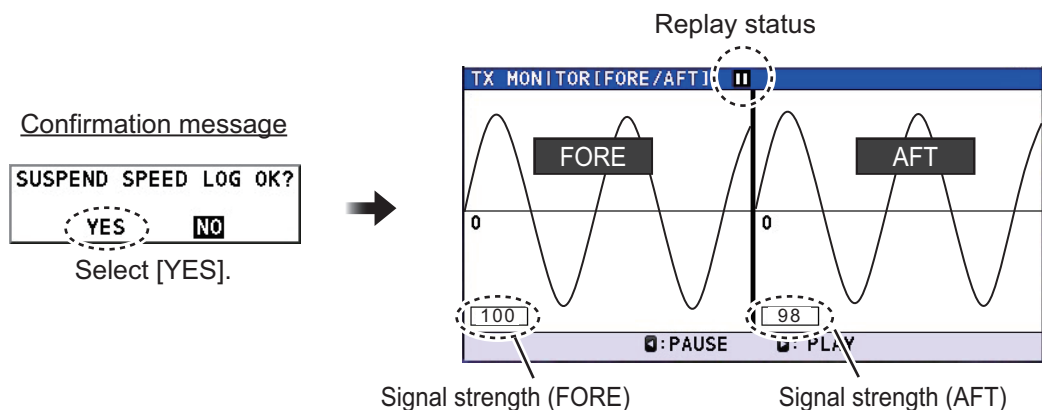
Show the transmission wave for FORE and AFT. During displaying the transmission wave, the ship's speed is not calculated.

Select [TX MONITOR] then the confirmation message appears. Select [YES] to show the [TX MONITOR]. To close the TX monitor, see "< MONITOR MENU >" on page 3-9.



- Wave data for FORE and AFT: The left half is for FORE data, and the right half is for AFT data. The wave data for FORE and AFT are updated alternately every second.
- Replay status:  means "PLAY",  means "PAUSE". Press the  key to start to update, and press the  key to pause the update.

< MONITOR MENU >

The [MONITOR MENU] can set the gain setting or transmission mode.

1. On the screen of [ECHO MONITOR] and [SA MONITOR] then press the **MENU/ESC** key to show the [MONITOR MENU].
2. Select [GAIN] or [TX MODE].

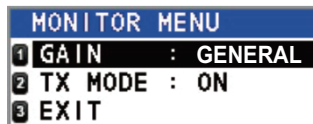

- [GAIN]: Set the gain level on each screen. The setting range is shown on the right-top of these screens as follows.
 - [GENERAL]: General use. [G] is shown on the screen.
 - [NOISE LEVEL]: For noise check. [N] is shown on the screen.
 - [INTERFERENCE]: For interference check. [I] is shown on the screen.
- [TX MODE]: Set [OFF] to stop transmission.
- [EXIT]: Go back to [EQUIPMENT MENU].

3. ADJUSTMENTS

3. After appropriate settings, select [EXIT] to go back to [EQUIPMENT MENU].

[ECHO MONITOR]

Show the color echo display according to the depth. During displaying the echo display, the ship's speed is not calculated.

Select [ECHO MONITOR] then the confirmation message appears. Select [YES] to show the [ECHO MONITOR]. To close the Echo monitor, see "< MONITOR MENU >" on page 3-9.

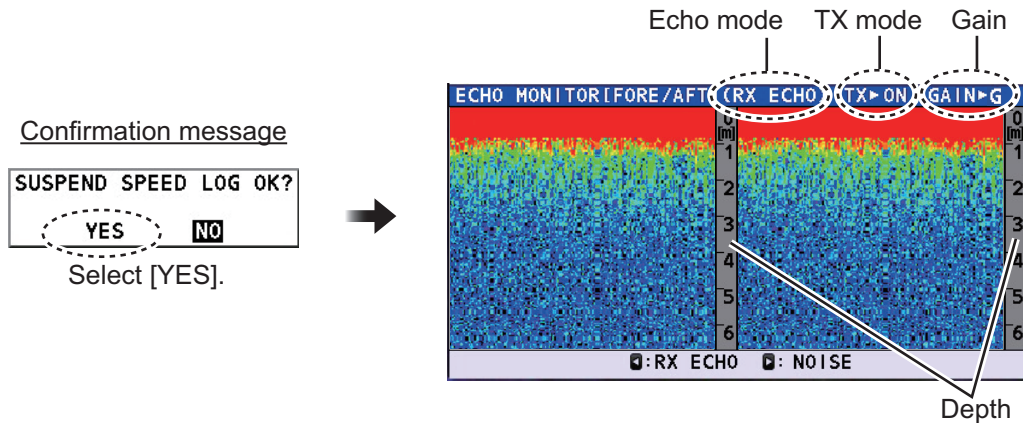

- Received echo data: The echo data is scrolled to the left and the latest data is shown at the right edge of each display screen. The display indicates echo strength in descending order of red>yellow>green>blue. The display changes with the echo mode as follows.
 - When the echo mode is [RX ECHO], the echo data on the transmitting side is displayed. The left half is data for FORE when transmitting on the FORE side, and the right half is data for AFT when transmitting on the AFT side.
 - When the echo mode is [NOISE], the echo data on the non-transmitting side is displayed. The left half is data for AFT when transmitting on the FORE side, and the right half is data for FORE when transmitting on the AFT side.
- Echo mode: Show the echo type. Press the ► key to show echo data for the speed calculating, and press the ◀ key to show the echo data for noise check.
- Depth: The vertical scale shows the depth according to the transducer setting.
- [TX]: The transmission mode which is set on the [MONITOR MENU] is shown. See "< MONITOR MENU >" on page 3-9 for details.
- [GAIN]: The gain level which is set on the [MONITOR MENU] is shown. See "< MONITOR MENU >" on page 3-9 for details.

[SA MONITOR]

Show the echo display to check the spectrogram for FORE and AFT. You can check the interference, noise, frequency or interval on this screen. During displaying the SA display, the ship's speed is not calculated.

Select [SA MONITOR] then the confirmation message appears. Select [YES] to show the [SA MONITOR]. To close the SA monitor, see "< MONITOR MENU >" on page 3-9.

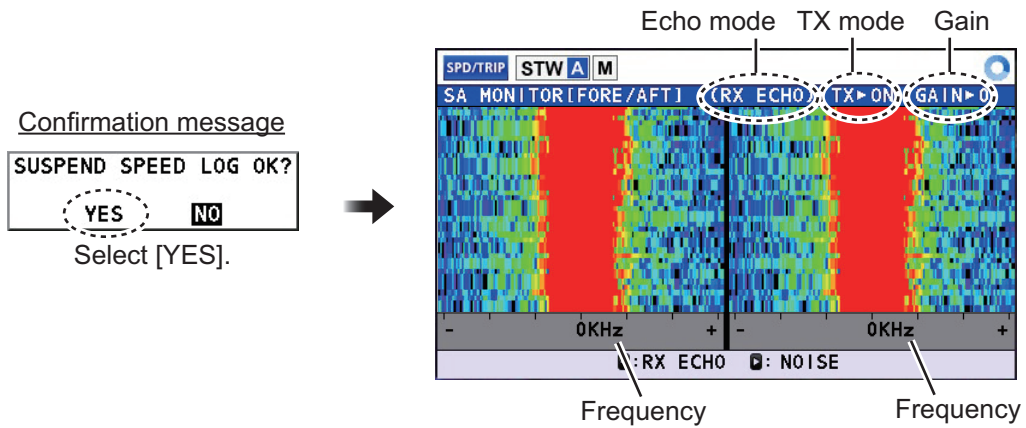

- Received echo data: The echo data is scrolled to the left and the latest data is shown at the right edge of each display screen. The display indicates echo strength in descending order of red>yellow>green>blue. The display changes with the echo mode as follows.
 - When the echo mode is [RX ECHO], the spectrogram on the transmitting side is displayed. The left half is spectrogram for FORE when transmitting on the FORE side, and the right half is spectrogram for AFT when transmitting on the AFT side.
 - When the echo mode is [NOISE], the spectrogram on the non-transmitting side is displayed. The left half is spectrogram for AFT when transmitting on the FORE side, and the right half is spectrogram for FORE when transmitting on the AFT side.
- Echo mode: Show the echo type. Press the ► key to show echo data for the speed calculating, and press the ◀ key to show the echo data for noise check.
- Frequency: The horizontal scale shows the frequency according to the transducer setting.
- [TX]: The transmission mode which is set on the [MONITOR MENU] is shown. See "< MONITOR MENU >" on page 3-9 for details.
- [GAIN]: The gain level which is set on the [MONITOR MENU] is shown. See "< MONITOR MENU >" on page 3-9 for details.

[ANALOG CHECK]

This screen is to check the analog circuit of the transceiver unit. For example, if you set 10 kn as ship's speed for test, check that 10 kn is displayed in the [RESULT]. If there is a discrepancy between this set value and the result, there may be a malfunction so contact your local dealer.

During displaying the [ANALOG CHECK] display, the ship's speed is not calculated. To go to the [MAINTENANCE] window, press the **MENU/ESC** key.

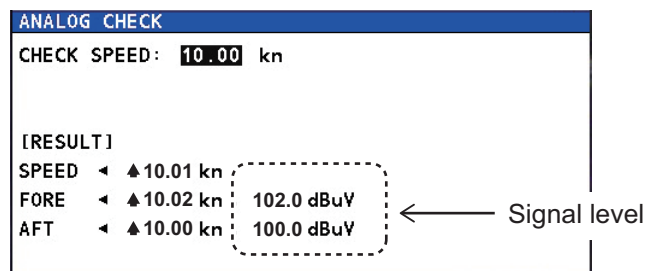

- [CHECK SPEED]: Set the ship's speed for test to check the analog circuit. The setting range is [-10.00] to [40.00] kn (default: [10.00] kn).

3. ADJUSTMENTS

- [SPEED]: Show the ship's speed/direction which the transceiver unit outputs. This value is updated every second. The setting range is [↓ 99.99] to [↑ 99.99] kn. Ship direction is indicated as follows: [↑] means "Go forward" and [↓] means "Go backward".
- [FORE], [AFT]: Show the ship's speed/direction and signal level which the transducer of FORE (or AFT) outputs. When an analog circuit activates properly, the signal level is 35 to 40 dBuV. This value is updated every second. Ship direction is indicated as follows: [↑] means "Go forward" and [↓] means "Go afterward".

[LAN ERROR COUNTER]

This screen is to show the error status of LAN connection. To go [MAINTENANCE] window, press the **MENU/ESC** key.

LAN ERROR COUNTER	
UDP CHECK SUM ERROR	◀ 0
INVALID HEADER	◀ 0
INCORRECT TAG BLOCK	◀ 0
TAG BLOCK CHECKSUM ERROR	◀ 0
TAG BLOCK SYNTAX ERROR	◀ 0
TAG BLOCK FRAMING ERROR	◀ 0
INCORRECT SENTENCE	◀ 0

- [UDP CHECKSUM ERROR]: Number of checksum errors in UDP headers.
- [INVALID HEADER]: Number of "UdPbC<NULL>" errors at the beginning of sentences.
- [INCORRECT TAG BLOCK]: Number of tag block structural errors.
- [TAG BLOCK CHECKSUM ERROR]: Number of checksum errors at the end of tag blocks.
- [TAG BLOCK SYNTAX ERROR]: Number of tag block format errors.
- [TAG BLOCK FRAMING ERROR]: Number of sentences with unexpected starts/stops in the tag block.
- [INCORRECT SENTENCE]: Number of sentences in tag block with checksum errors or other errors.

3.5 [TEST] menu

On the main menu, select [EQUIPMENT] → [TEST] to open the option menus of [TEST] sub menu.

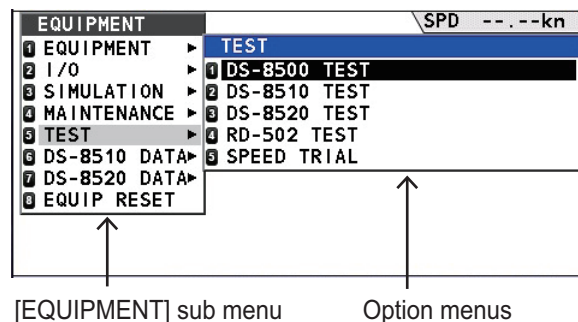

3.5.1 [DS-8500 TEST] menu

The test result of Display Unit DS-8500, the equipment information, ROM/RAM test or serial port test etc., is shown on this menu. The test result has four pages.

[DS-8500 TEST (1/4)]: page 1

DS-8500 TEST(1/4)	
SERIAL NO.	◀ 000000
STARTER VERSION	◀ 6550302-01.02(20190307)
BOOT VERSION	◀ 6550303-01.02(20190307)
	6550303-01.02(20190307)
APPLICATION VERSION	◀ 6550304-01.02(20190307)
ROM / RAM	◀ OK/OK
PORT	◀ OK
LCD TOTAL TIME	◀ 15500h
12 VOLT	◀ 12.1V

Item	Meaning	Range
[SERIAL NO.]	Serial number of display unit	[000000] to [999999]
[STARTER VERSION]	Starter version of display unit	[6550302-01.01] to [6550302-99.99]
[BOOTER VERSION]	<ul style="list-style-type: none"> Upper: Booter version used for start-up of display unit. Lower: Booter version not used (back-up) for start-up of display unit 	[6550303-01.01] to [6550303-99.99]
[APPLICATION VERSION]	Application version of display unit	[6550304-01.01] to [6550304-99.99]
[ROM/RAM]	Result of ROM test/Result of RAM test	[OK] or [NG]
[PORT]	Result of serial port	[OK] or blank
[LCD TOTAL TIME]	Total operation hours of LCD.	[0] to [999999] (h)
[12 VOLT]	Voltage value of display unit	[0.0] to [99.9] (V)
▶ key	Go to page 2 of the [DS-8500 TEST].	
MENU/ESC key	Go back to [EQUIPMENT] sub menu.	

[DS-8500 TEST (2/4)]: page 2

DS-8500 TEST(2/4)	
LCD BACK LIGHT	◀ 13
KEY BACK LIGHT	◀ 4

Item	Meaning	Range
[LCD BACK LIGHT]	Automatic brilliance test of LCD is started. The brilliance is changed according to the displayed value.	[0] to [17] (First value: [17])
[KEY BACK LIGHT]	Brilliance of key back light	[0] to [17] (default: [0])
▶ key	Go to page 3 of the [DS-8500 TEST].	
MENU/ESC key	Go back to [EQUIPMENT] sub menu.	

[DS-8500 TEST (3/4)]: page 3

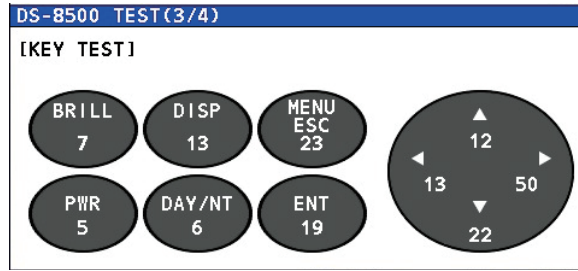

Each key is shown in gray. The color changes to red when the corresponding key is pressed, then changes to blue color when the key is released.

The number of times the key has been tested is shown under each key name.

Press the **▶** key three times to show the fourth page of [DS-8500 TEST]. You can also to press the **MENU/ESC** key three times to return the [TEST] sub menu.



Number of times for key check

[DS-8500 TEST (4/4)]: page 4

By pressing the **▶** key, switch the selection of the display color type; Black→White→Red→Green→Blue→Gray→Multi (◀ key: reverse sequence).

To check the guide message display, press the **DISP** key.

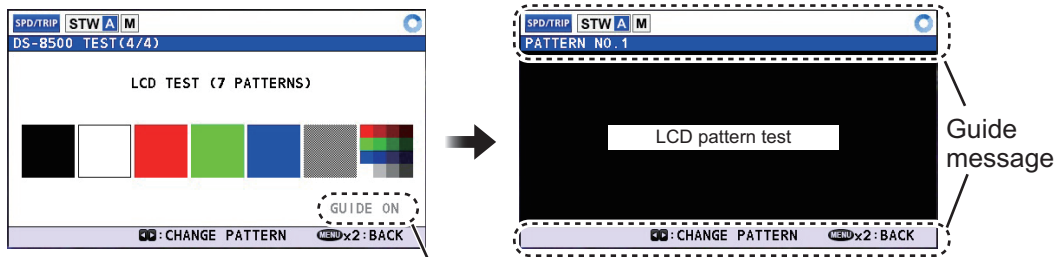

Press [DISP] key.

3.5.2 DS-8510 TEST

The test result of distributor unit DS-8510, the equipment information, ROM/RAM test etc., is shown on this menu. The test result has three pages.

[DS-8510 TEST (1/3)]: page 1

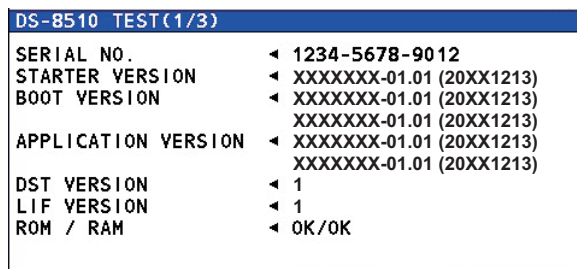

Item	Meaning	Range
[SERIAL NO.]	Serial number of distributor unit	[0000-0000-0000] to [9999-9999-9999]
[STARTER VERSION]	Starter version of distributor unit	[6550306-01.01] to [6550306-99.99]
[BOOT VERSION]	<ul style="list-style-type: none"> Upper: Booter version used for start-up of the distributor unit. Lower: Booter version not used (backup) for start-up of the distributor unit. 	[6550307-01.01] to [6550307-99.99]
[APPLICATION VERSION]	<ul style="list-style-type: none"> Upper: Application version used for start-up of the distributor unit. Lower: Application version not used (backup) for start-up of the distributor unit. 	[6550308-01.01] to [6550308-99.99]
[DST VERSION]	DIST board version	[0] to [E], [-] (NG)
[LIF VERSION]	LIF board version	[0] to [E]
[ROM/RAM]	Result of ROM test/Result of RAM test	[OK] or [NG]
▶ key	Go to page 2 of the [DS-8510 TEST].	
MENU/ESC key	Go back to [TEST] sub menu.	

DS-8510 TEST (2/3): page 2

DS-8510 TEST (2/3)	
IP ADDRESS	◀ 172.031.016.123
SUBNET MASK	◀ 255.255.000.000
GATEWAY	◀ 172.031.001.001
MAC ADDRESS	◀ 00 : D0 : 1D : 3E : 99 : 2F
DIPSW	◀ S3 : 0000 S4 : 0000
TOTAL TIME	◀ 21h
FAN RPM	◀ 4500 rpm
INTERNAL TEMPERATURE	◀ 30 . 1 °C
5 VOLT	◀ 5 . 0V
12 VOLT	◀ 12. 2V

Item	Meaning	Range
[IP ADDRESS]	IP address of distributor unit	[000.000.000.000] to [255.255.255.255]
[SUBNET MASK]	Subnet mask of distributor unit	[000.000.000.000] to [255.255.255.255]
[GATEWAY]	Gateway of distributor unit	[000.000.000.000] to [255.255.255.255]
[MAC ADDRESS]	MAC address of distributor unit	[00:00:00:00:00:00] to [FF:FF:FF:FF:FF:FF]
[DIPSW]	Status DISPSW of distributor unit	S3: [0000] to [1111] S4: [0000] to [1111]
[TOTAL TIME]	Total time for operation of distributor unit	[0] to [999999]
[FAN RPM]	Revolution of FAN	
[INTERNAL TEMPERATURE]	Temperature for board of distributor unit	[-99.9] to [999.9] (°C)
[5 VOLT]	Voltage of 5 V for distributor unit	[0.0] to [99.9]
[12 VOLT]	Voltage of 12 V for distributor unit	[0.0] to [99.9]
▶ key	Go to page 3 of the [DS-8510 TEST].	
MENU/ESC key	Go back to [TEST] sub menu.	

[DS-8510 TEST (3/3)]: page 3

DS-8510 TEST (3/3)		
[SIO]		[USB]
CH1	◀	USB R/W
CH2	◀	
DS-8520	◀ OK	
MAIN	◀	
SUB1	◀	
SUB2	◀	
RD-502	◀ OK	

Item	Meaning	Range
[SIO]: SIO communication test		
[CH1]	Result of CH1 communication test	[OK] or blank
[CH2]	Result of CH2 communication test	[OK] or blank
[DS-8520]	Result of transceiver unit communication	[OK] or blank
[MAIN]	Result of MAIN communication	[OK] or blank
[SUB1]	Result of SUB1 communication	[OK] or blank
[SUB2]	Result of SUB2 communication	[OK] or blank
[RD-502]	Result of RD-502 communication	[OK] or blank
[USB]: USB communication test		
[USB R/W]	Check if reading or writing to USB	[OK] or blank
MENU/ESC key	Go back to [TEST] sub menu.	

3.5.3 DS-8520 TEST

The test result of Transceiver Unit DS-8520, the equipment information, ROM/RAM test results or serial port test result etc., is shown on this menu. The test result has three pages.

[DS-8520 TEST (1/3)]: page 1

DS-8520 TEST (1/3)	
SERIAL NO.	◀ 345678
STARTER VERSION	◀ XXXXXXX-01.01 (20XX1213)
BOOT VERSION	◀ XXXXXXX-01.01 (20XX1213)
	XXXXXXX-01.01 (20XX1213)
APPLICATION VERSION	◀ XXXXXXX-01.01 (20XX1213)
FPGA VERSION	◀ XXXXXXX-01.01 (20XX1213)
MAIN VERSION	◀ A
TRX VERSION	◀ B
ROM / RAM	◀ OK/OK
BUBBLE	◀ 123

Item	Meaning	Range
[SERIAL NO.]	Serial number of transceiver unit	[000000] to [999999]
[STARTER VERSION]	Starter version of transceiver unit	[6550311-01.01] to [6550311-99.99]
[BOOT VERSION]	<ul style="list-style-type: none"> Upper: Booter version used for start-up of the transceiver unit . Lower: Booter version not used (backup) for start-up of the transceiver unit 	[6550312-01.01] to [6550312-99.99]
[APPLICATION VERSION]	Application version of transceiver unit.	[6550313-01.01] to [6550313-99.99]

Item	Meaning	Range
[FPGA VERSION]	FPGA version	[6550314-01.01] to [6550314-99.99]
[MAIN VERSION]	Main board version	[0] to [E], [-] (NG)
[TRX VERSION]	TRX board version	[0] to [E], [-] (NG)
[ROM/RAM]	Result of ROM test/Result of RAM test	[OK] or [NG]
[BUBBLE]	Value of bubble effects ([5] or less ideally)	[0] to [255]
▶ key	Go to page 2 of the [DS-8520 TEST].	
MENU/ESC key	Go back to [TEST] sub menu.	

[DS-8520 TEST (2/3)]: page 2

DS-8520 TEST(2/3)	
IP ADDRESS	◀ 192 . 168 . 200 . 001
SUBNET MASK	◀ 255 . 255 . 255 . 000
GATEWAY	◀ 000 . 000 . 000 . 000
MAC ADDRESS	◀ FF : FF : FF : FF : FF : FF
DIPSW	◀ S2 : 0001 S3 : 0000 S5 : 0000
TOTAL DIST	◀ 0 . 04NM

Item	Meaning	Range
[IP ADDRESS]	IP address of transceiver unit	[000.000.000.000] to [255.255.255.255]
[SUBNET MASK]	Subnet mask of transceiver unit	[000.000.000.000] to [255.255.255.255]
[GATEWAY]	Gateway of transceiver unit	[000.000.000.000] to [255.255.255.255]
[MAC ADDRESS]	MAC address of transceiver unit	[00:00:00:00:00:00] to [FF:FF:FF:FF:FF:FF]
[DIPSW]	Status DIP switch of transceiver unit	S2: [0000] to [1111] S3: [0000] to [1111] S5: [0000] to [1111]
[TOTAL DIST]	Total distance	[0.00] to [999999.99]
▶ key	Go to page 3 of the [DS-8520 TEST].	
MENU/ESC key	Go back to [TEST] sub menu.	

[DS-8520 TEST (3/3)]: page 3

DS-8520 TEST(3/3)	
XDCR TEMPERATURE	◀ --- . --
TRX TEMPERATURE	◀ 32 . 8°C
B VOLT	◀ 25 . 5V
5 VOLT	◀ 5 . 0V
12 VOLT	◀ 12 . 1VA / 11 . 9VD
24 VOLT	◀ 25 . 6V
FAN RPM	◀ 4803rpm
NOISE LEVEL (FORE / AFT)	◀ 8.3 / 11 . 5 dBuV
SPEED (FORE / AFT)	◀ ↑32 . 14/ ↓32 . 22kn

3. ADJUSTMENTS

Item	Meaning	Range
[XDCR TEMPERATURE]	Temperature of Transducer	[-99.9] to [999.9] ([---.]: circuit error, or no connection to transducer)
[TRX TEMPERATURE]	Temperature of TRX board on Transducer	[-99.9] to [999.9]
[PWR TEMP]	Temperature of PWR board for transceiver unit	[-99.9] to [999.9]
[B VOLT]	B voltage of transceiver unit	[0.0] to [99.9]
[5 VOLT]	Voltage of 5 V for transceiver unit	[0.0] to [99.9]
[12 VOLT]	Voltage of 12 V for transceiver unit	[0.0] to [99.9]
[24 VOLT]	Voltage of 24 V for transceiver unit	[0.0] to [99.9]
[FAN RPM]	Revolution of FAN	[0] to [999999]
[NOISE LEVEL (FORE/AFT)]	Noise level of FORE/AFT transducer	[-20] to [120.0]
[SPEED (FORE/AFT)]	Measured ship's speed (FORE/AFT)	[-99.99] to [99.99]
MENU/ESC key	Go back to [TEST] sub menu.	

3.5.4 RD-502 TEST

Check the connection between DS-85 and the optional Dimmer RD-502.

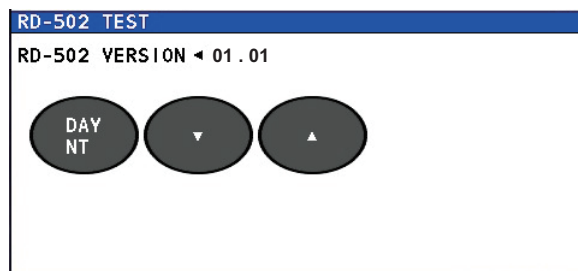

Item	Meaning
[RD-502 VERSION]	Version of RD-502
DAY/NT key	By pressing DAY/NT key of RD-502, changed figure color red → blue → red
▼ key	By pressing ▼ key of RD-502, changed figure color red → blue → red
▲ key	By pressing ▲ key of RD-502, changed figure color red → blue → red
MENU/ESC key	Go back to [TEST] sub menu.

3.5.5 SPEED TRIAL

Show the average ship's speed for the specified period. Set the trial time then press the ► key to start the trial. To stop the trial test, press the ◀ key. If a USB flash memory is connected to the distributor unit, the distributor unit outputs the trial result.

Note: To output the results to a USB flash memory, connect a USB to the USB port in the distributor unit (shown the in figure above-right).

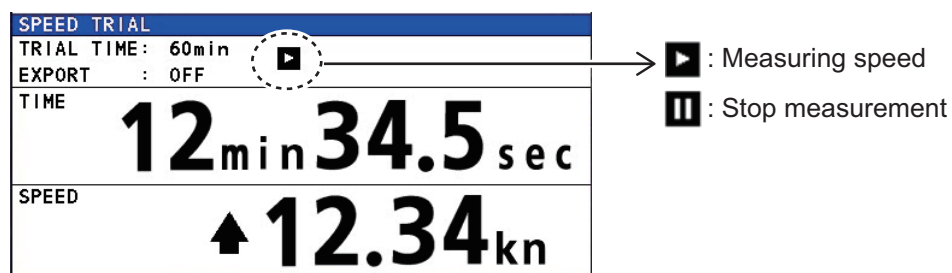
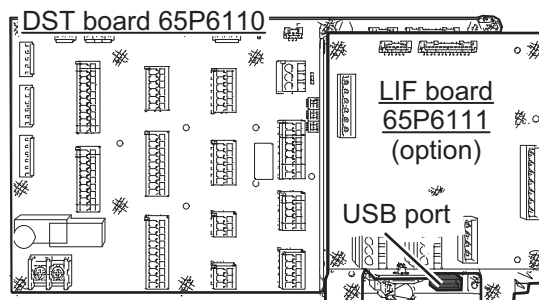

Item	Meaning	Range
[TRIAL TIME]	Trial time (min)	[10] to [60]
[EXPORT]	Set [ON] to export the measurement result to an USB device.	[ON] or [OFF]
[TIME]	Elapsed time from trial start	[00 min 00.0 sec] to [60 min 00.0 sec]
[SPEED] or [SPEED (AVERAGE)]	[SPEED]: Ship's speed at that moment during measurement [SPEED (AVERAGE)]: Average ship's speed during measurement The unit of measurement can be changed in the [UNIT] menu (Main menu→[DISPLAY]→[UNIT]).	[↓ 99.999] to [↑ 99.999]
◀ key	Stop measurement	
▶ key	Start measurement	
MENU/ESC key	Go back to [TEST] sub menu.	

Use this menu as follows:

1. Set a longer time at [TRIAL TIME].
2. Set [ON] at [EXPORT].
3. Press ► key to start ship's speed measurement. If a USB device is connected to the distributor unit, exporting measurement result to a USB device begins.
4. Press ◀ key to stop ship's speed measurement. Record the average ship's speed shown. If a USB device is connected to the distributor unit, exporting is stopped.

3.6 [DS-8510 DATA]/[DS-8520 DATA] sub menu

These menus are for serviceman only. Contact your local dealer for details.

3.7 [EQUIP RESET] sub menu

This menu can reset the all [EQUIPMENT] menu settings. On the main menu, select [EQUIPMENT] → [EQUIP RESET] to show the confirmation message below.

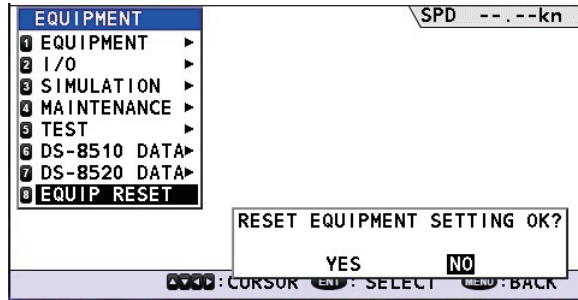

Select [YES] on the confirmation message to reset all settings of the [EQUIPMENT] menu.

3.8 How to Set SFI

Open the [SERVICE] menu then set own SFI.

1. Select the [SERVICE] menu on the main menu. To open the [SERVICE] menu, the password is required. For the password, ask our service man.
2. Select [NETWORK] → [NETWORK] to show the [NETWORK] window.

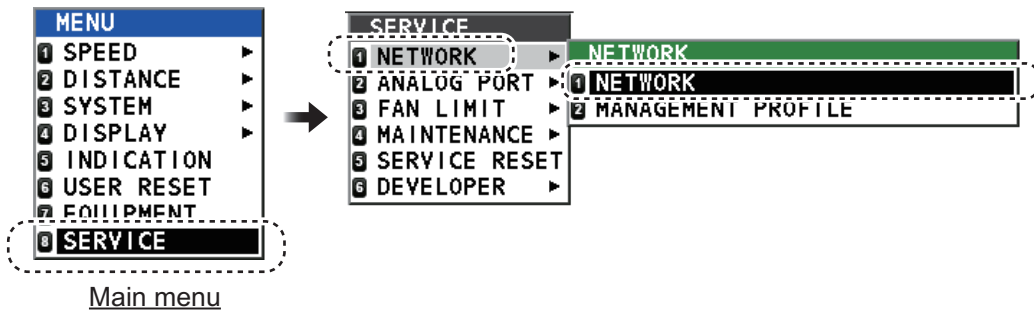

3. Move the cursor the item for [OWN SFI] on the [NETWORK] window.

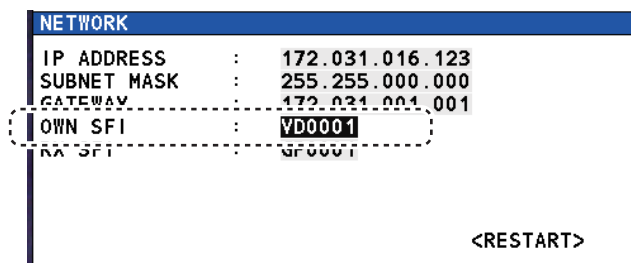

4. Set the SFI number for this equipment. SFI numbers contain six characters, two letters and four digits. The setting range is [AA0001] to [ZZ9998].
5. After setting, press the **ENT** key. The confirmation message "PLEASE RESTART IN ORDER TO UPDATE SETTING." appears.
6. Select [RESTART] to update the SFI.

3.9 How to Offset for Analog Port

Set the offset value for the analog output port.

1. Select the [SERVICE] menu on the main menu. To open the [SERVICE] menu, the password is required. For the password, ask our service man.
2. Select [ANALOG PORT] and then set the analog port ([PORT1] to [PORT4]) to set.
3. Select [MODE] and then select the type of analog port.
 [DISCONNECT]: For no connection to analog port (default).
 [DISP1]: For analog display unit of range to 30 kn
 [DISP2]: For analog display unit of range to 40 kn
 [DISP3]: For analog display unit of range to 20 kn
 [CUR]: For analog current signal (4 to 20 mA)
 [VOLT]: For analog voltage signal (-3.3 to 10 V)
4. Select the analog port to offset then the setting window appears. The offset setting window to be set depends on the analog port.
 [DISP]: Set for PORT1 to PORT4.
 [CURRENT]: Set for PORT3 to PORT4.
 [VOLTAGE]: Set for PORT4 only.
5. Select [START SETTING] to show the confirmation message "START SETTING OK?". Then select [YES] to start setting. To stop setting, press the **MENU** key to go back to the [SERVICE] menu.

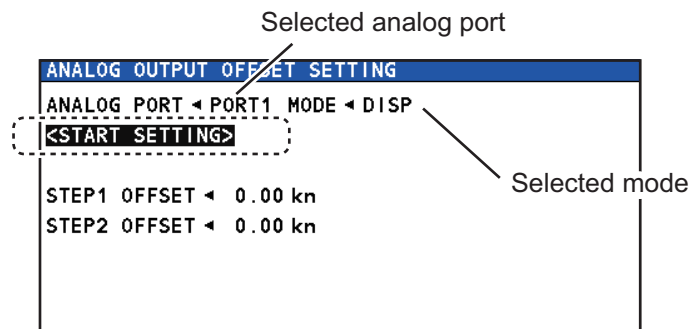

6. Set the offset value in the [STEP1 OFFSET] field so that the needle of the analog display unit will be "0 kn", and click [NEXT]. The setting range is -4.9 to 4.9 kn. To stop setting, press the **MENU** key to go back to the [SERVICE] menu. For example, when the analog display unit indicates 2 kn, set "2" (kn) on this window so that the analog display unit indicates 0 kn.

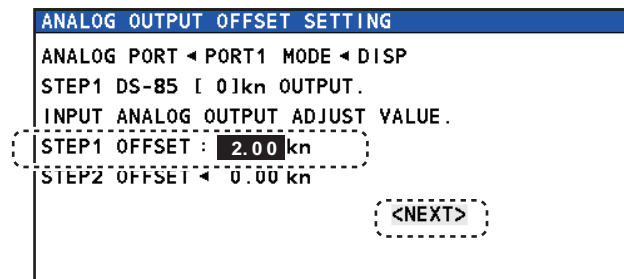

3. ADJUSTMENTS

7. Set the offset value in the [STEP2 OFFSET] field so that the needle of the analog display unit will be "**10 kn**", and click [OK] to complete setting. The setting range is -4.9 to 4.9 kn. To stop setting, press the **MENU** key to go back to the [SERVICE] menu.

For example, when the analog display unit indicates 9 kn, set "-1" (kn) on this window so that the analog display unit indicates 10 kn.

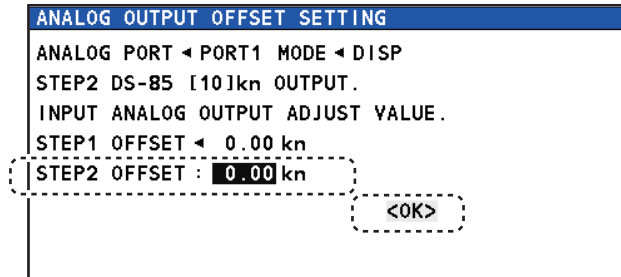

APPX. 1 JIS CABLE GUIDE

Cables listed in the manual are usually shown as Japanese Industrial Standard (JIS). Use the following guide to locate an equivalent cable locally.

JIS cable names may have up to 6 alphabetical characters, followed by a dash and a numerical value (example: DPYC-2.5).

For core types D and T, the numerical designation indicates the *cross-sectional Area (mm²)* of the core wire(s) in the cable.

For core types M and TT, the numerical designation indicates the *number of core wires* in the cable.

1. Core Type

D: Double core power line

T: Triple core power line

M: Multi core

TT: Twisted pair communications
(1Q=quad cable)

2. Insulation Type

P: Ethylene Propylene Rubber

3. Sheath Type

Y: PVC (Vinyl)

4. Armor Type

C: Steel

5. Sheath Type

Y: Anticorrosive vinyl sheath

6. Shielding Type

SLA: All cores in one shield, plastic tape w/aluminum tape

-SLA: Individually shielded cores, plastic tape w/aluminum tape



EX: ^{1 3 4 5 6} TTYCYSLA - 4
 Designation type | # of twisted pairs

EX: ^{1 2 3 4} MPYC - 4
 Designation type | # of cores

The following reference table lists gives the measurements of JIS cables commonly used with Furuno products:

Type	Area	Core Diameter	Cable Diameter	Type	Area	Core Diameter	Cable Diameter
DPYC-1.5	1.5mm ²	1.56mm	11.7mm	TTYCSLA-1	0.75mm ²	1.11mm	9.4mm
DPYC-2.5	2.5mm ²	2.01mm	12.8mm	TTYCSLA-1T	0.75mm ²	1.11mm	10.1mm
DPYC-4	4.0mm ²	2.55mm	13.9mm	TTYCSLA-1Q	0.75mm ²	1.11mm	10.8mm
DPYC-6	6.0mm ²	3.12mm	15.2mm	TTYCSLA-4	0.75mm ²	1.11mm	15.7mm
DPYC-10	10.0mm ²	4.05mm	17.1mm	TPYCY-1	0.75mm ²	1.11mm	11.0mm
DPYCY-1.5	1.5mm ²	1.56mm	13.7mm	TPYCY-1T	0.75mm ²	1.11mm	11.7mm
DPYCY-2.5	2.5mm ²	2.01mm	14.8mm	TPYCY-1Q	0.75mm ²	1.11mm	12.6mm
DPYCY-4	4.0mm ²	2.55mm	15.9mm	TPYCY-4	0.75mm ²	1.11mm	17.7mm
MPYC-2	1.0mm ²	1.29mm	10.0mm	TPYCY-4SLA	0.75mm ²	1.11mm	19.5mm
MPYC-4	1.0mm ²	1.29mm	11.2mm	TTYCYSLA-1	0.75mm ²	1.11mm	11.2mm
MPYC-7	1.0mm ²	1.29mm	13.2mm	TTYCYSLA-4	0.75mm ²	1.11mm	17.9mm
MPYC-12	1.0mm ²	1.29mm	16.8mm	TTPYCSLA-1	0.75mm ²	1.11mm	9.2mm
TPYC-1.5	1.5mm ²	1.56mm	12.5mm	TTPYCSLA-1T	0.75mm ²	1.11mm	9.8mm
TPYC-2.5	2.5mm ²	2.01mm	13.5mm	TTPYCSLA-1Q	0.75mm ²	1.11mm	10.5mm
TPYC-4	4.0mm ²	2.55mm	14.7mm	TTPYCSLA-4	0.75mm ²	1.11mm	15.3mm
TPYCY-1.5	1.5mm ²	1.56mm	14.5mm				
TPYCY-2.5	2.5mm ²	2.01mm	15.5mm				
TPYCY-4	4.0mm ²	2.55mm	16.9mm				

APPX. 2 DIGITAL INTERFACE

Priority for input data/sentences

Sentence (Priority)	Contents
GNS>GGA>RMC>GLL	Position
VTG>RMC	Speed over ground
VTG>RMC	Course over ground
ZDA	Date

Priority for ports

LAN > Serial (CH1) > Serial (CH2)

Digital Interface

- **Input sentences:** ACN, GGA, RMC, VTG, ZDA
- **Output sentences:** ALC, ALF, ALR, POS, VBW, VHW, VLW
- **Transmission interval:** 1 s for VBW, VHW, VLW
- **Data transmission**

Data is transmitted in serial asynchronous form in accordance with the standard referenced in 2.1 of IEC 61162-1/2. The first bit is a start bit and is followed by data bits, least-significant-bit as illustrated below.

The following parameters are used:

Baud rate: 38400 bps/4800 bps

Data bits: 8 (D7 = 0), parity none

Stop bits: 1

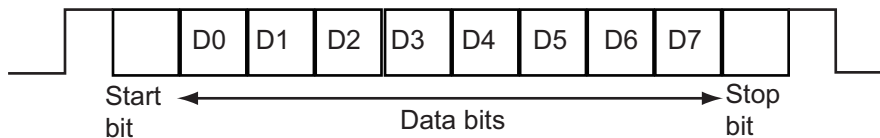

- **Data digit**

The ship's speed data (VBW, VHW) has two digits after the decimal point (default setting). To change digit after the decimal point, set S4 of the DIP switch to ON on the DST board of the distributor unit.

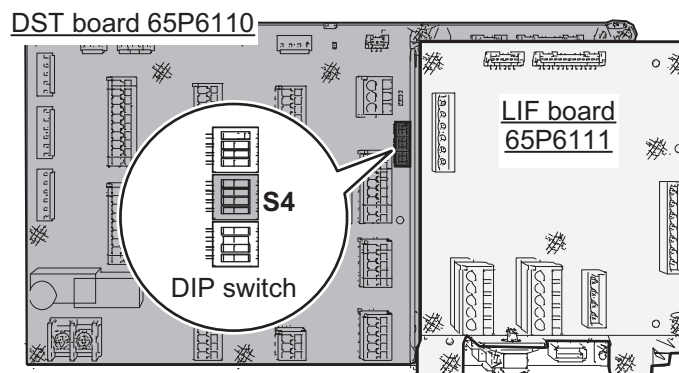

Sentence description**Input sentences****ACN - Alert command**

```
$**ACN,hhmmss.ss,aaa,x.x,x.x,c,a*hh<CR><LF>
      1      2 3 4 5 6
```

1. Time (No use)
2. Manufacturer mnemonic code (3 characters, null)
3. Alert Identifier (000 - 9999999)
4. Alert Instance (0 - 999999, null)
5. Alert command (A,Q,O,S)
 - A=acknowledge
 - Q=request/repeat information
 - O=responsibility transfer
 - S=silence
6. Sentence status flag(C) (fixed)

GGA - Global Positioning System (GPS) fix data

```
$**GGA,hhmmss.ss,llll.ll,a,yyyyy.yy,a,x,xx,x.x,x.x,M,x.x,M,x.x,xxxx*hh<CR><LF>
      1      2 3 4 5 6 7 8 9 10 11 12 13 14
```

1. UTC of position (No use)
2. Latitude (No use)
3. N/S (No use)
4. Longitude (No use)
5. E/W (No use)
6. GPS quality indicator (1 to 5)
7. Number of satellite in use (No use)
8. Horizontal dilution of precision (No use)
9. Antenna altitude (No use)
10. Unit (No use)
11. Geoidal separation (No use)
12. Unit (No use)
13. Age of differential GPS data (No use)
14. Differential reference station ID (No use)

RMC - Recommended minimum specific GNSS data

```
$**RMC,hhmmss.ss,A,llll.ll,a,yyyyy.yy,a,x.x,x.x,ddmmyy,x.x,a,a*hh<CR><LF>
      1      2 3 4 5 6 7 8 9 10 11 12 13
```

1. UTC of position fix (No use)
2. Status (A=data valid)
3. Latitude (No use)
4. N/S (No use)
5. Longitude (No use)
6. E/W (No use)
7. Speed over ground, knots (0.00 - 999.99)
8. Course over ground, degrees true (0.00 - 359.99)
9. Date (No use)
10. Magnetic variation, degrees (No use)
11. E/W (No use)
12. Mode indicator (A= Autonomous mode D=Differential mode F=Float RTK P=Precise
R=Real time kinematic)
13. Navigational status indication (S=Safe)

VTG - Course over ground and ground speed

\$**VTG,x,x,T,x,x,M,x,x,N,x,x,K,a*hh <CR><LF>
1 2 3 4 5 6 7 8 9

1. Course over ground, degrees True (0.00 to 359.99)
2. T=True (fixed)
3. Course over ground, degrees Magnetic (No use)
4. M=Magnetic (fixed)
5. Speed over ground, knots (0.00 to 999.99)
6. N=Knots (fixed)
7. Speed over ground (0.00 to 999.99)
8. K=km/h (fixed)
9. Mode indicator (A=Autonomous, D=Differential P=Precise)

ZDA - Time and date

\$- ZDA,hhmmss.ss,xx,xx,xxxx,xx,xx*hh<CR><LF>
1 2 3 4 5 6

1. UTC (000000 to 235959.99)
2. Day (01 to 31, UTC)
3. Month (01 to 12, UTC)
4. Year (0000 to 9999, UTC)
5. Local zone, hours (No use)
6. Local zone, minutes (No use)

Output sentences

ALC - Cyclic alert list

\$**ALC,xx,xx,xx,xx,aaa,x,x,x,x,x,x,x,x,x,x*hh<CR><LF>
1 2 3 4 5 6 7 8 9

1. Total number of sentences this message (01 to 99)
2. Sentence number (01 to 99)
3. Sequential message identifier (00 to 99)
4. Number of alert entries (0 to 3)
5. Manufacturer mnemonic code (FEC)
6. Alert identifier (211000 to 211999)
7. Alert instance (1 to 2, null)
8. Revision counter (1 to 99)
9. Additional alert entries (same as #5 to #8)

ALF - Alert sentence

\$**ALF,x,x,x,hhmmss.ss,a,a,a,aaa,x,x,x,x,x,x,x,c--c*hh<CR><LF>
1 2 3 4 5 6 7 8 9 10 11 12 13

1. Total number of ALF sentences this message (1, 2)
2. Sentence number (1, 2)
3. Sequential message identifier (0 to 9)
4. Time of last change (hhmmss.ss, hh: 00 to 23, mm: 00 to 59, ss.ss: 00.00 to 59.99, null)
5. Alert category (B=Alert category B, null when #2 is 2)
6. Alert priority (C=Caution, null when #2 is 2)
7. Alert state (A=ACKed, N=Normal state, null when #2 is 2)
8. Manufacturer mnemonic code (FEC)
9. Alert identifier (211000 to 211999)
10. Alert instance (1 to 2, null)
11. Revision counter (1 to 99)
12. Escalation counter (0 to 9)
13. Alert text (max. 16 characters)

ALR - Set Alarm State

\$**ALR,hhmmss.ss,xxx,A,A,c—c*hh<CR><LF>
 1 2 3 4 5

1. Time of alarm condition change, UTC (hhmmss.ss, hh: 00 to 23, mm: 00 to 59, ss.ss: 00.00 to 59.99, null)
2. Unique alarm number (identifier) at alarm source (000 to 999, null when no alarm)
3. Alarm condition (A=threshold exceeded, V=not exceeded)
4. Alarm acknowledge state (A=acknowledged, V=not acknowledged)
5. Alarm description text (alphanumeric)

POS - Device position and ship dimensions report or configuration command

\$**POS,cc,xx,a,x.x,x.x,x.x,a,x.x,x.x,a*hh<CR><LF>
 1 2 3 4 5 6 7 8 9 10

1. Equipment Identification (VD)
2. Equipment number (01 to 99)
3. Position validity flag (A=Valid)
4. Position X-coordinate (-999.9 to 999.9)
5. Position Y-coordinate (0.0 to 999.9)
6. Position Z-coordinate (null)
7. Ship's width/length (V=Invalid)
8. Ship's width (null)
9. Ship's length (null)
10. Sentences status flag (R=Sentence is status report of current settings)

VBW - Dual ground/water speed

\$**VBW,x.x,x.x,A,x.x,x.x,A,x.x,A,x.x,A*hh<CR><LF>
 1 2 3 4 5 6 7 8 9 10

1. Longitudinal water speed, knots (-999.9 to 999.9 (or -999.99 to 999.99), null)
2. Transverse water speed, knots (null)
3. Status: water speed (A=Data valid V=Data invalid)
4. Longitudinal ground speed, knots (null)
5. Transverse ground speed, knots (null)
6. Status: ground speed (V=Data invalid)
7. Stern transverse water speed, knots (null)
8. Status: stern water speed (V=Data invalid)
9. Stern transverse ground speed, knots (null)
10. Status: stern ground speed (V=Data invalid)

VHW - Water speed and heading

\$**VHW,x.x,T,x.x,M,x.x,N,x.x,K*hh<CR><LF>
 1 2 3 4 5 6 7 8

1. Heading, degrees True (null)
2. T=True (fixed)
3. Heading, degrees Magnetic (null)
4. M=Magnetic (fixed)
5. Speed, knots (-999.9 to 999.9 (or -999.99 to 999.99), null)
6. N=Knots (fixed)
7. Speed, km/hr (-999.9 to 999.9 (or -999.99 to 999.99), null)
8. K=km/hr (fixed)

VLW - Dual ground/water distance

\$**VLW,x.x,N,x.x,N,x.x,N,x.x,N*hh<CR><LF>
1 2 3 4 5 6 7 8

1. Total cumulative water distance (0.00 to 2147483.65, null)
2. N=Nautical miles
3. Water distance since reset (0.00 to 2147483.65, null)
4. N=Nautical miles
5. Total cumulative ground distance (null)
6. N=Nautical miles
7. Ground distance since reset (null)
8. N=Nautical miles

APPX. 3 CALIBRATION

For an accurate display of speed, a speed trial test to find the difference between your actual speed and the speed calculated by the equipment is necessary. Since DS-85 can measure only the speed against water, calibration is performed using round trip data in the same sea area to minimize the effect of tidal currents.

Note: To obtain accurate offset values, it is recommended to conduct the test using similar conditions and speeds to a regular voyage.

Calibration from the speed trial

Calibration values can be calculated by comparing the doppler speed log with DGPS or other similar speed measuring devices.

1) **Calibration from the speed trial**

Speed trial result conducted using a GPS milepost may differ depending on the shipyard's measurement methods, as shown below:

- a) The ship's speed is calculated based on the time traveled.
- b) The ship's fore/aft (Y-axis) speed is calculated based on the time traveled.
- c) Calculation is based on a one-mile course, traveled three times.
- d) Calculation is based on the time traveled over a predetermined time.

Offset calculation for the above methods is described below.

a) Calculate the ship's speed with the measured total time of trip distance

Vectors are combined to calculate the ship speed. The DS-85 can only measure the speed of the ship bow and stern, so errors may occur depending on the sea conditions.

Steer the ship at a steady speed for 10 minutes or longer on the test course (EG: A to B in the figure). The ship's speed data is collected as VBW fore/aft speed (taken immediately after switching to water-based speed) data. Calculate the error with the average speed, from the GPS mile post meter and the speed data which DS-85 outputs, then enter the correction value so that the error are eliminated.

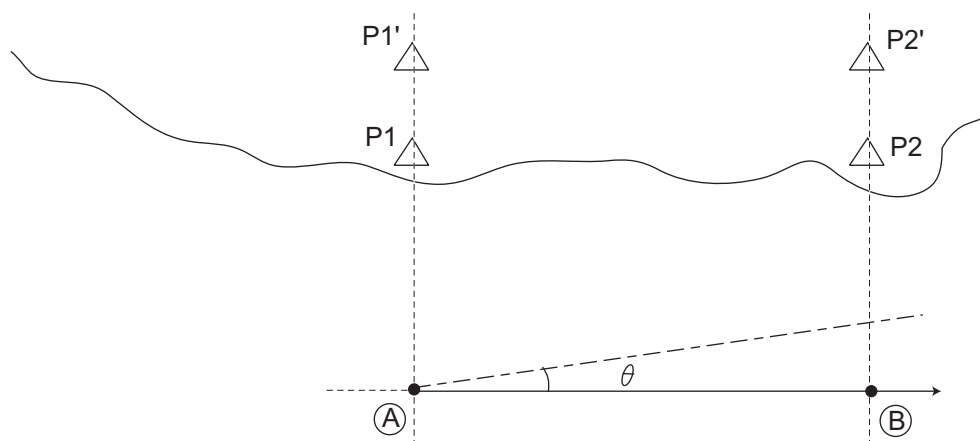

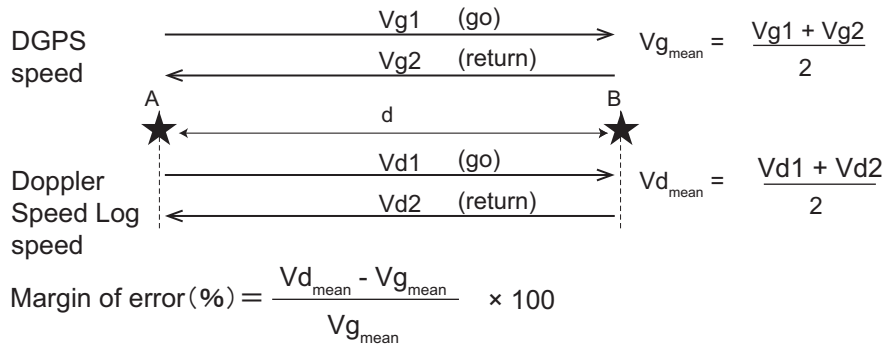

Where; d: distance run (NM), V_{g1} , V_{g2} : GPS measured speed (kn), V_{d1} , V_{d2} : doppler speed log measured speed (kn).

By conducting the same test using different speed conditions, you can obtain varied sampling data. Use the average values to calculate a calibration value and allow a 2% margin of error.

Note 1: For how to enter the speed calculation, see SPEED CAL menu (main menu→ [SYSTEM]→[SPEED CAL]) in the operator’s manual.

Note 2: To measure the average trial speed, use the speed trial function (see section 3.5.5).

- b) The ship's fore/aft (Y-axis) speed is calculated based on the time traveled.
This method uses the fore/aft (Y-axis) speed as the GPS milepost. The calculation is made by the **VBW speed** (taken immediately after switching to water-based speed).
- c) Calculation is based on a one-mile course, traveled three times.
Calculation is done with the same method as a).
- d) Calculation is based on the time traveled over a predetermined time.
Calculation is done with the same method as a).

2) **How to use survey poles as a milepost**

Calculation is done using b) from method 1).



TEST SHEET FOR DOPPLER SPEED LOG

Type: _____ Serial No.: _____
 Date: _____ Place: _____ Ship's length: _____ m Draft: Fore: _____ m
 Ship's Name: _____ Hull No.: _____ Shipyard: _____ Aft: _____ m

RUN No.	Engine		DGPS	Doppler Speed Log			Shipyard Data			Note		
	Load (%)	Rev. (rpm)		Speed (kn)	Tracking Mode	Speed (kn)	*1 Error (%)	Calibration (%)	Depth (m)		Course (deg)	Wind (m/s)
-												
-												
Mean												
-												
-												
Mean												
-												
-												
Mean												
-												
-												
Mean												
-												
-												
Mean												
-												
-												
Mean												
-												
-												
Mean												

*1 Error = $\frac{\text{DS Speed (NM)} - \text{DGPS (NM)}}{\text{DGPS (NM)}} \times 100 (\%)$



Owner's Signature: _____
 Company name: _____
 Engineer's Signature: _____

PACKING LIST

65AE-X-9851 -0 1/1

DS-8500/-HK

A-1

NAME	UNIT	OUTLINE	DESCRIPTION/CODE No.	Q'TY
指示器 DISPLAY UNIT			DS-8500-*	1
			000-037-351-00 **	
工事材料 INSTALLATION MATERIALS				
工事材料 INSTALLATION MATERIALS			CP05-13701	1
			001-443-270-00	

コード番号末尾の[**]は、選択品の代表コードを表します。
CODE NUMBER ENDING WITH "**" INDICATES THE CODE NUMBER OF REPRESENTATIVE MATERIAL.

(略図の寸法は、参考値です。DIMENSIONS IN DRAWING FOR REFERENCE ONLY.)

CN





C7288-Z01-A

PACKING LIST

65AE-X-9852 -0 1/1

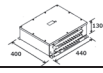
DS-8510-1*/-1*/-HK, DS-8510-2*/-2*/-HK

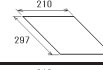
A-2

NAME	UNIT	OUTLINE	DESCRIPTION/CODE No.	Q'TY
分配器 DISTRIBUTOR UNIT			DS-8510-*	1
			000-037-392-00 **	
予備品 SPARE PARTS				
予備品 SPARE PARTS			SP65-01101	1
			001-569-930-00	
工事材料 INSTALLATION MATERIALS				
工事材料 INSTALLATION MATERIALS			CP65-01501	1
			001-569-940-00	
図書 DOCUMENT				
取扱説明書 OPERATOR'S MANUAL			OM*-72880-*	1
			000-197-137-1* **	
装備要領書 INSTALLATION MANUAL			IM*-72880-*	1
			000-197-139-1* **	

コード番号末尾の[**]は、選択品の代表コードを表します。
CODE NUMBER ENDING WITH "**" INDICATES THE CODE NUMBER OF REPRESENTATIVE MATERIAL.

(略図の寸法は、参考値です。DIMENSIONS IN DRAWING FOR REFERENCE ONLY.)



C7288-Z02-A

PACKING LIST

65AE-X-9853 -0 1/1

DS-8520/-HK

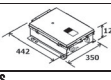
A-3

NAME	UNIT	OUTLINE	DESCRIPTION/CODE No.	Q'TY
送受信機 TRANSCIVER UNIT			DS-8520-*	1
			000-037-358-00 **	
予備品 SPARE PARTS				
予備品 SPARE PARTS			SP65-01001	1
			001-569-860-00	
工事材料 INSTALLATION MATERIALS				
工事材料 INSTALLATION MATERIALS			CP65-01401	1
			001-569-870-00	

コード番号末尾の[**]は、選択品の代表コードを表します。
CODE NUMBER ENDING WITH "**" INDICATES THE CODE NUMBER OF REPRESENTATIVE MATERIAL.

(略図の寸法は、参考値です。DIMENSIONS IN DRAWING FOR REFERENCE ONLY.)

C7288-Z03-A

PACKING LIST

65AE-X-9854 -0 1/1

DS-8530-*

A-4

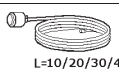
NAME	UNIT	OUTLINE	DESCRIPTION/CODE No.	Q'TY
送変波器 TRANSDUCER UNIT			DS-8530-*	1
			000-037-360-00 **	

コード番号末尾の[**]は、選択品の代表コードを表します。
CODE NUMBER ENDING WITH "**" INDICATES THE CODE NUMBER OF REPRESENTATIVE MATERIAL.

(略図の寸法は、参考値です。DIMENSIONS IN DRAWING FOR REFERENCE ONLY.)

C7288-Z04-A



表1 TABLE 1

寸法区分 (mm) DIMENSION	公差 (mm) TOLERANCE
L ≤ 50	±1.5
50 < L ≤ 100	±2.5
100 < L ≤ 500	±3

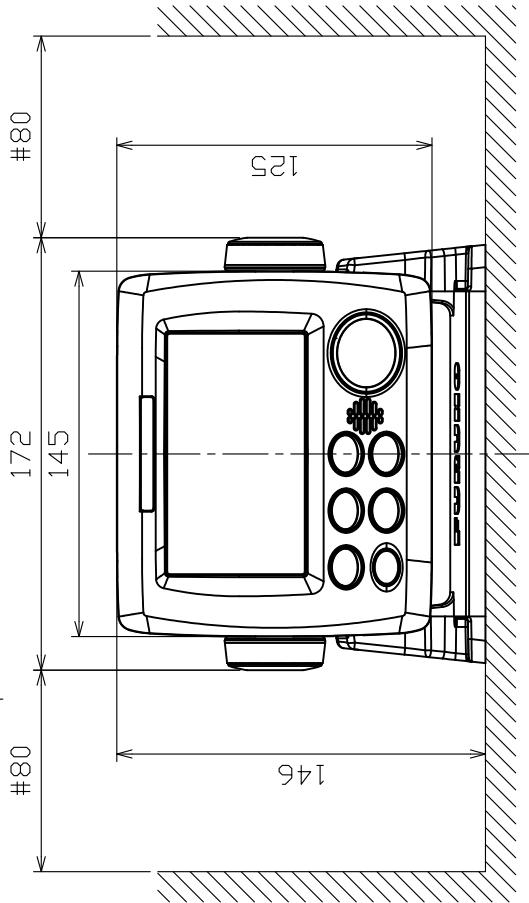
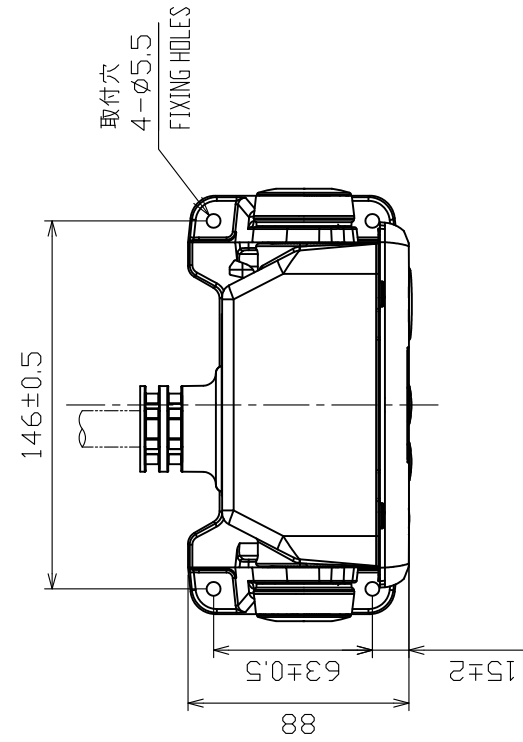
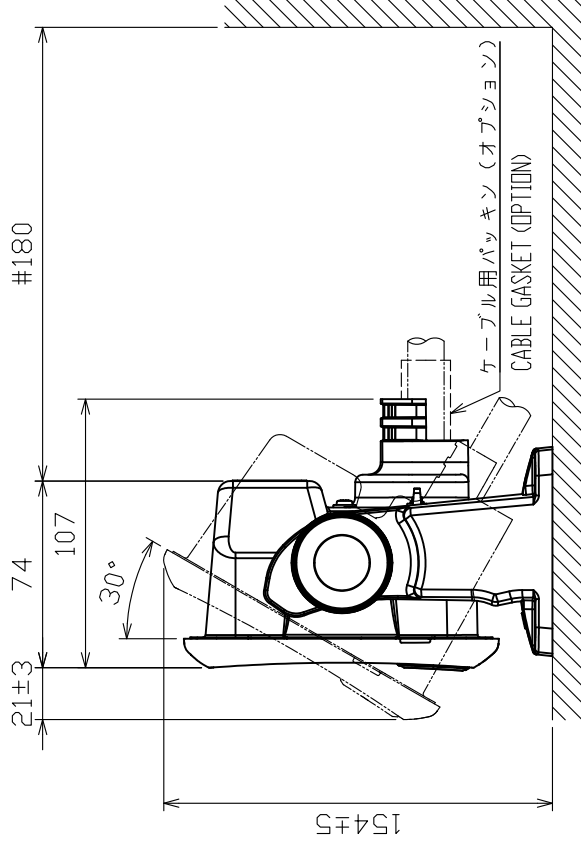
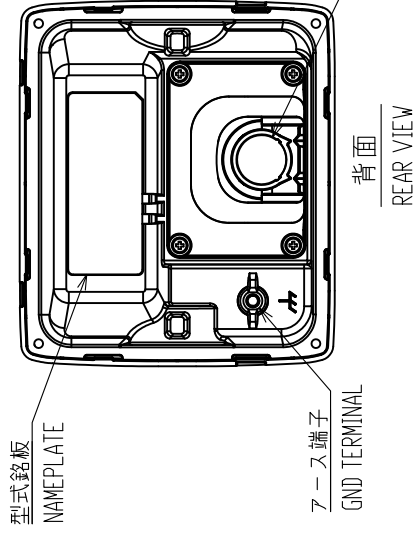

- 注記
- 1) 指定なき寸法公差は表 1 による。
 - 2) # 印寸法は、最小サービスマウントとする。
 - 3) 取付用ネジはトラスタスピネジ呼び径5×2.0を使用のこと。
- NOTE
1. TABLE 1 INDICATES TOLERANCE OF DIMENSIONS WHICH IS NOT SPECIFIED.
 2. #: MINIMUM SERVICE CLEARANCE.
 3. USE TAPPING SCREWS φ5x2.0 FOR FIXING THE UNIT.

DRAWN	25/Jun/2019	I. YAMASAKI	TITLE	DS-8500
CHECKED	25/Jun/2019	H. MAKI	名称	指示器 (卓上装備)
APPROVED	28/Sep/2019	H. MAKI	外寸図	
SCALE	1/3	MASS 0.7 kg 寸法質量はオプションを含みません。 MASS DOES NOT INCLUDE OPTION.	NAME	DISPLAY UNIT (TABLETOP MOUNT)
DWG. No.	C7288-002-A	REF. No.	65-008-100-1	OUTLINE DRAWING



表1 TABLE 1

寸法区分 (mm) DIMENSION	公差 (mm) TOLERANCE
L ≤ 50	±1.5
50 < L ≤ 100	±2.5
100 < L ≤ 500	±3

- 注記 1) 指定外寸法公差は表 1 による。
 2) # 印寸法は、最小サービス空間寸法とする。
 3) 取付用ネジはナベタップピンネジ呼び径 3 × 2.0 を使用のこと。
- NOTE 1. TABLE 1 INDICATES TOLERANCE OF DIMENSIONS WHICH IS NOT SPECIFIED.
 2. #: MINIMUM SERVICE CLEARANCE.
 3. USE TAPPING SCREWS φ3x2.0 FOR FIXING THE UNIT.

DRAWN	26/Jun/2019	I. YAMASAKI	TITLE	DS-8500
CHECKED	26/Jun/2019	H. MAKI	名称	指示器 (埋込装備)
APPROVED	28/Sep/2019	H. MAKI	外寸図	
SCALE	1/3	質量 0.6 kg 寸法はオプションを含みません。 MASS DOES NOT INCLUDE OPTION.	NAME	DISPLAY UNIT (FLUSH MOUNT)
DWG. No.	C7288-003-A	REF. No.	65-008-1110-1	OUTLINE DRAWING

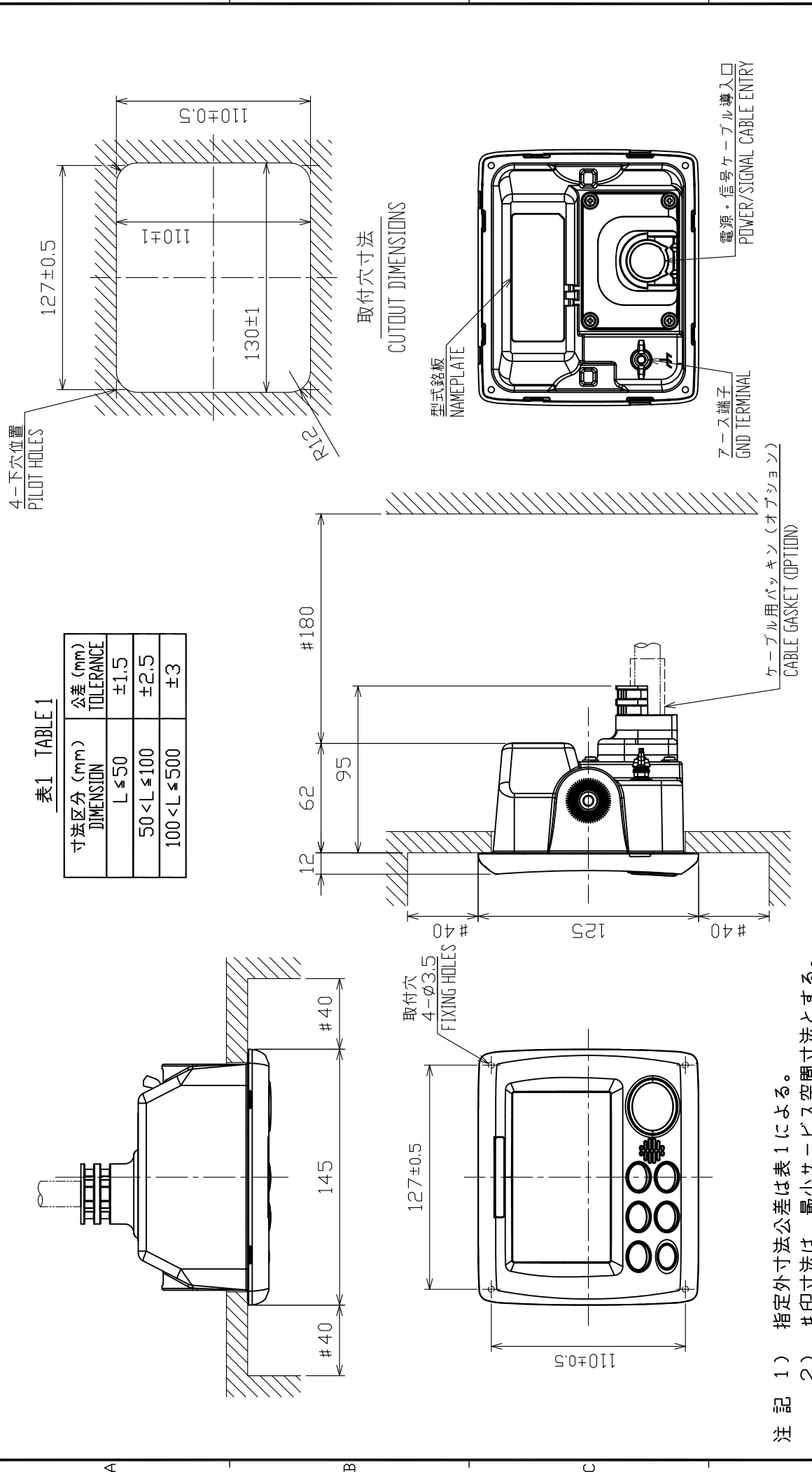

表1 TABLE 1

寸法区分 (mm) DIMENSION	公差 (mm) TOLERANCE
L ≤ 50	±1.5
50 < L ≤ 100	±2.5
100 < L ≤ 500	±3

注 記

- 1) 指定外寸法公差は表1による。
- 2) #印寸法は、最小サービス空間寸法とする。
- 3) 取付用ネジはトラスタッピピンネジ呼び径4×16を使用のこと。

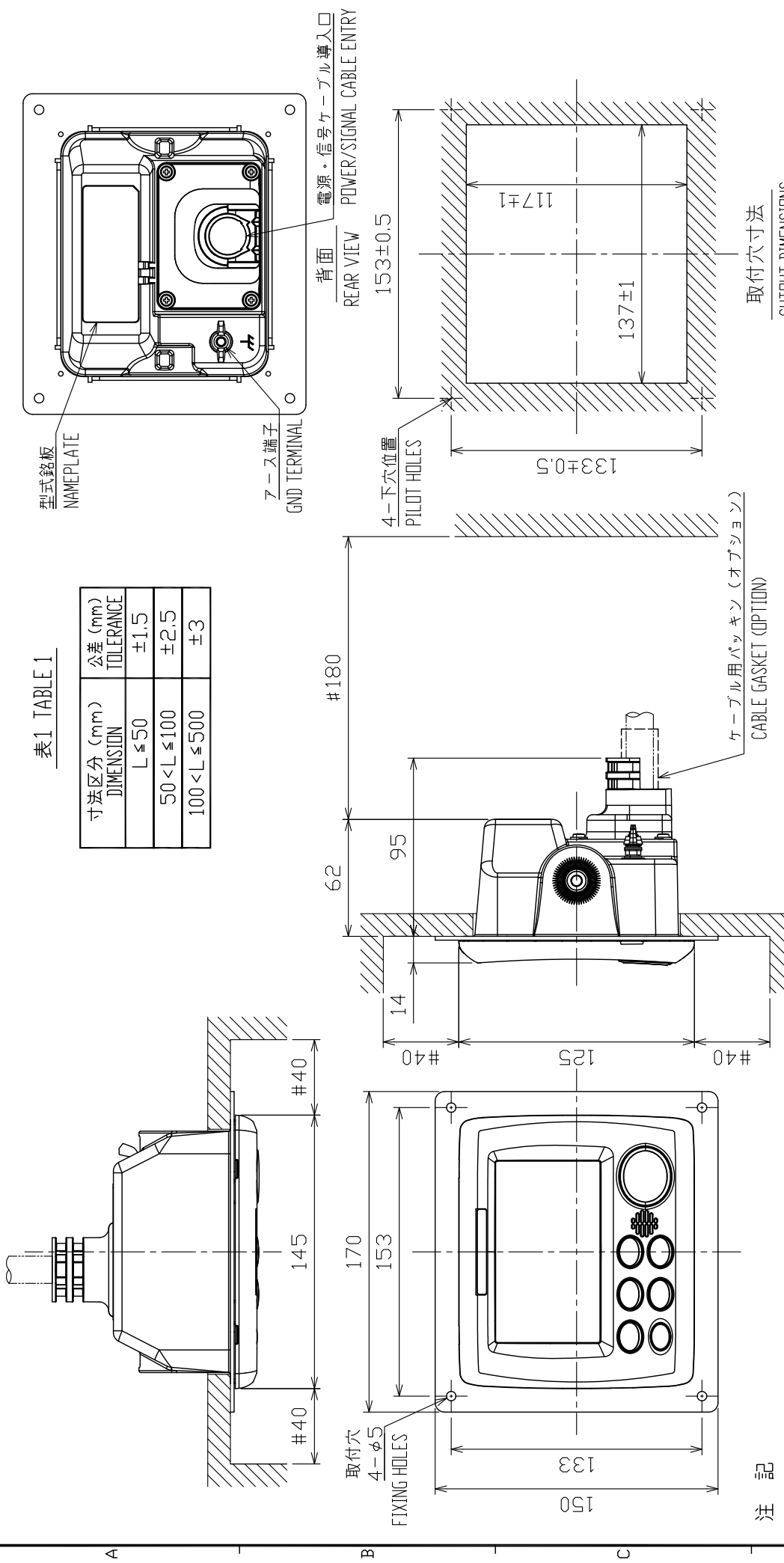
NOTE

1. TABLE 1 INDICATES TOLERANCE OF DIMENSIONS WHICH IS NOT SPECIFIED.
2. # MINIMUM SERVICE CLEARANCE.
3. USE TAPPING SCREWS φ4x16 FOR FIXING THE UNIT.

DRAWN	19/Oct/2019	I.YAMASAKI	TITLE	DS-8500
CHECKED	19/Oct/2019	H.MAKI	名称	指示器 (パネル装備)
APPROVED	29/Oct/2019	H.MAKI	外寸図	DS-85
SCALE	1/3	MASS 0.65 kg	質量はオプションを含みません。 MASS DOES NOT INCLUDE OPTION.	DISPLAY UNIT (PANEL MOUNT)
FIG.No.	C7288-606-A	REF.No.	65-008-112G-0	OUTLINE DRAWING



表1 TABLE 1

寸法区分 (mm) DIMENSION	公差 (mm) TOLERANCE
L ≤ 50	±1.5
50 < L ≤ 100	±2.5
100 < L ≤ 500	±3

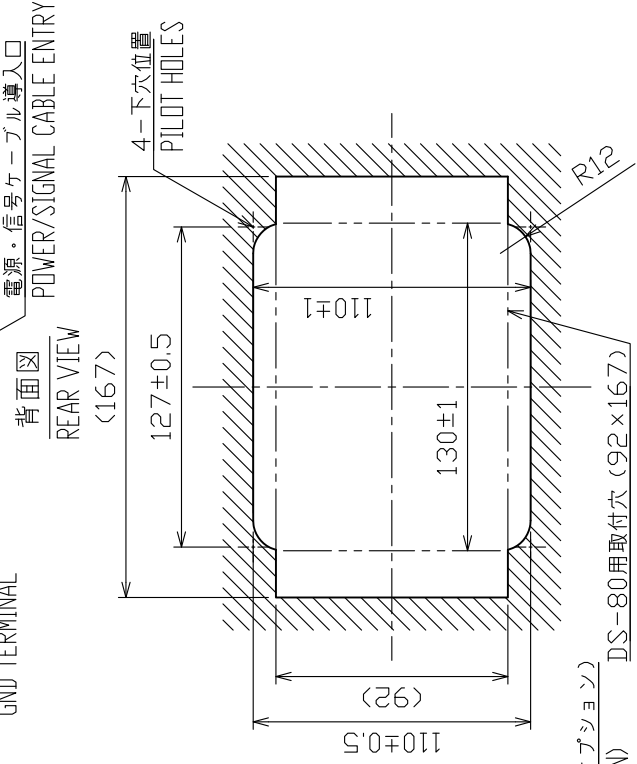
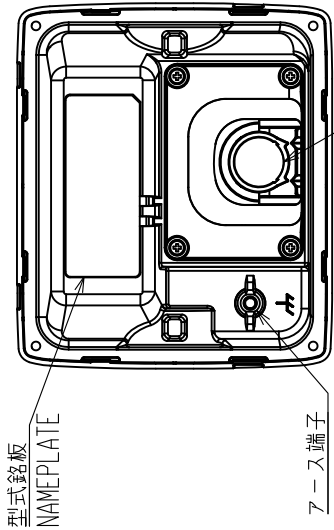
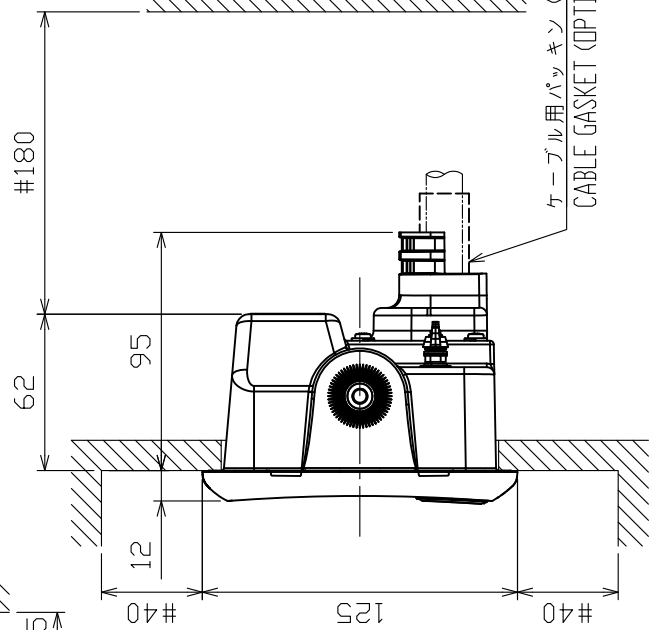

注 記

- 1) 指定外寸法公差は表 1 による。
- 2) # 印寸法は、最小サービスクリアランスとする。
- 3) 取付用ネジはナベタツピピンネジ呼び径 3 × 2.0 を使用のこと。

NOTE

1. TABLE 1 INDICATES TOLERANCE OF DIMENSIONS WHICH IS NOT SPECIFIED.
2. # MINIMUM SERVICE CLEARANCE.
3. USE TAPPING SCREWS φ3×2.0 FOR FIXING THE UNIT.

DRAWN	17/Feb/2020	I. YAMASAKI	TITLE	DS-8500
CHECKED	17/Feb/2020	H. MAKI	名称	指示器 (埋込装備・換装)
APPROVED	18/Feb/2020	H. MAKI	外寸図	
SCALE	1/3	MASS 0.60 kg	仕様	質量はオプションを含まず。 MASS DOES NOT INCLUDE OPTION.
JWG No.	C7288-607-B	REF. No.	65-008-113G-0	OUTLINE DRAWING



表1 TABLE 1

寸法区分 (mm) DIMENSION	公差 (mm) TOLERANCE
L ≤ 50	±1.5
50 < L ≤ 100	±2.5
100 < L ≤ 500	±3

取付寸法(M8使用時)
FIXING DIMENSIONS (FOR M8 BOLTS)

注記

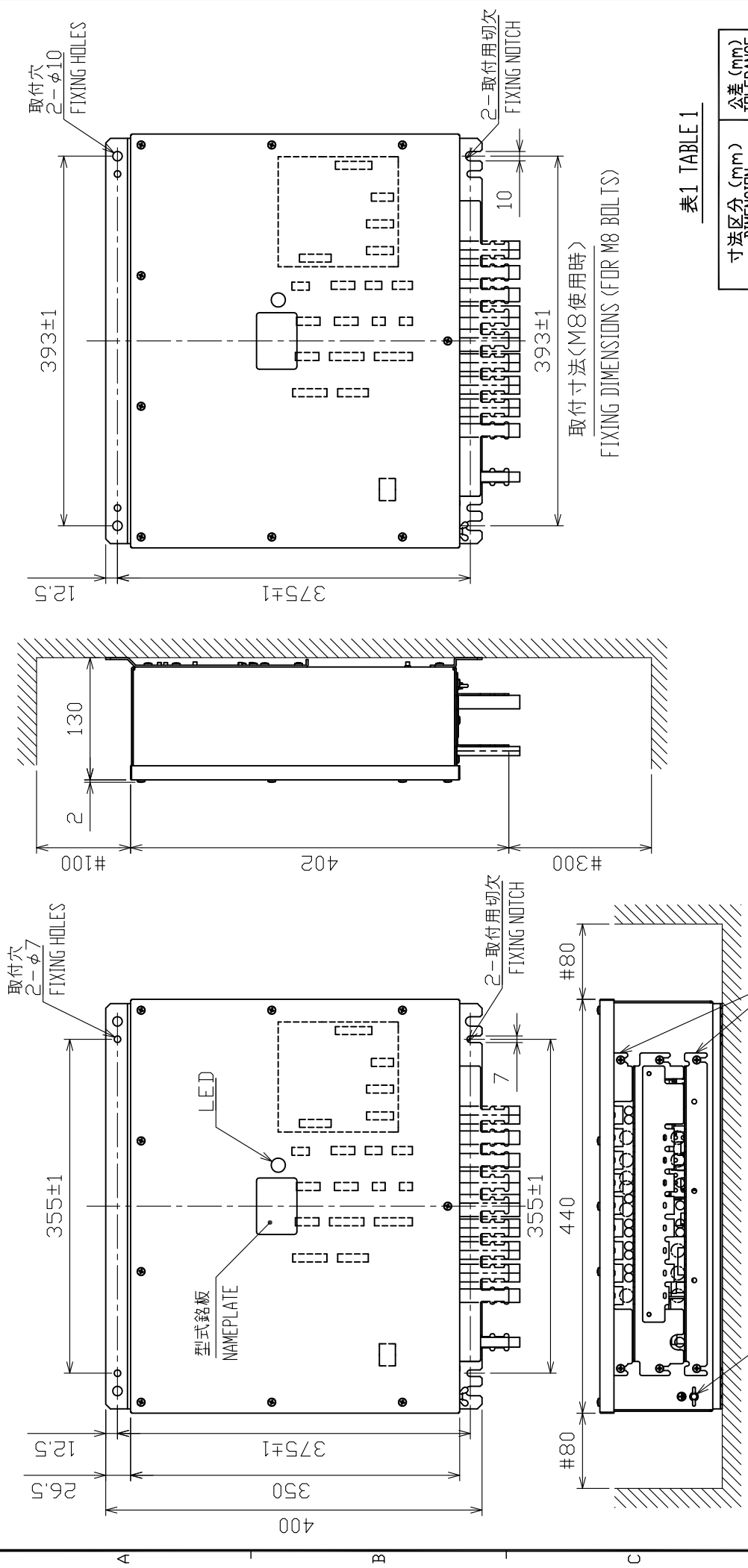
- 1) 指定外の寸法公差は表1による。
- 2) #印寸法は最小サービスマージン寸法とする。
- 3) 取付用ネジはトラスタッピンネジ呼び径6×30またはM6/M8ボルトを使用のこと。

NOTE

1. TABLE 1 INDICATES TOLERANCE OF DIMENSIONS WHICH IS NOT SPECIFIED.
2. #: MINIMUM SERVICE CLEARANCE.
3. USE TAPPING SCREWS Ø6x30 OR M6/M8 BOLTS FOR FIXING THE UNIT.

DRAWN	3/Apr/2020	I.YAMASAKI	TITLE	DS-8510
CHECKED	3/Apr/2020	H.MAKI	名称	分配器 (壁掛・卓上装備)
APPROVED	3/Apr/2020	H.MAKI	図号	外寸図
SCALE	1/6	MASS 12.8 kg	機種	DISTRIBUTOR UNIT (BULKHEAD/TABLE TOP MOUNT)
JWG No.	C7288-604-B	REF. No.	65-008-120G-4	OUTLINE DRAWING



表1 TABLE 1

寸法区分 (mm) DIMENSION	公差 (mm) TOLERANCE
L ≤ 50	±1.5
50 < L ≤ 100	±2.5
100 < L ≤ 500	±3

NOTE

1. TABLE 1 INDICATES TOLERANCE OF DIMENSIONS WHICH IS NOT SPECIFIED.
2. # MINIMUM SERVICE CLEARANCE.
3. USE TAPPING SCREWS Ø6x30 OR M6/M8 BOLTS FOR FIXING THE UNIT.

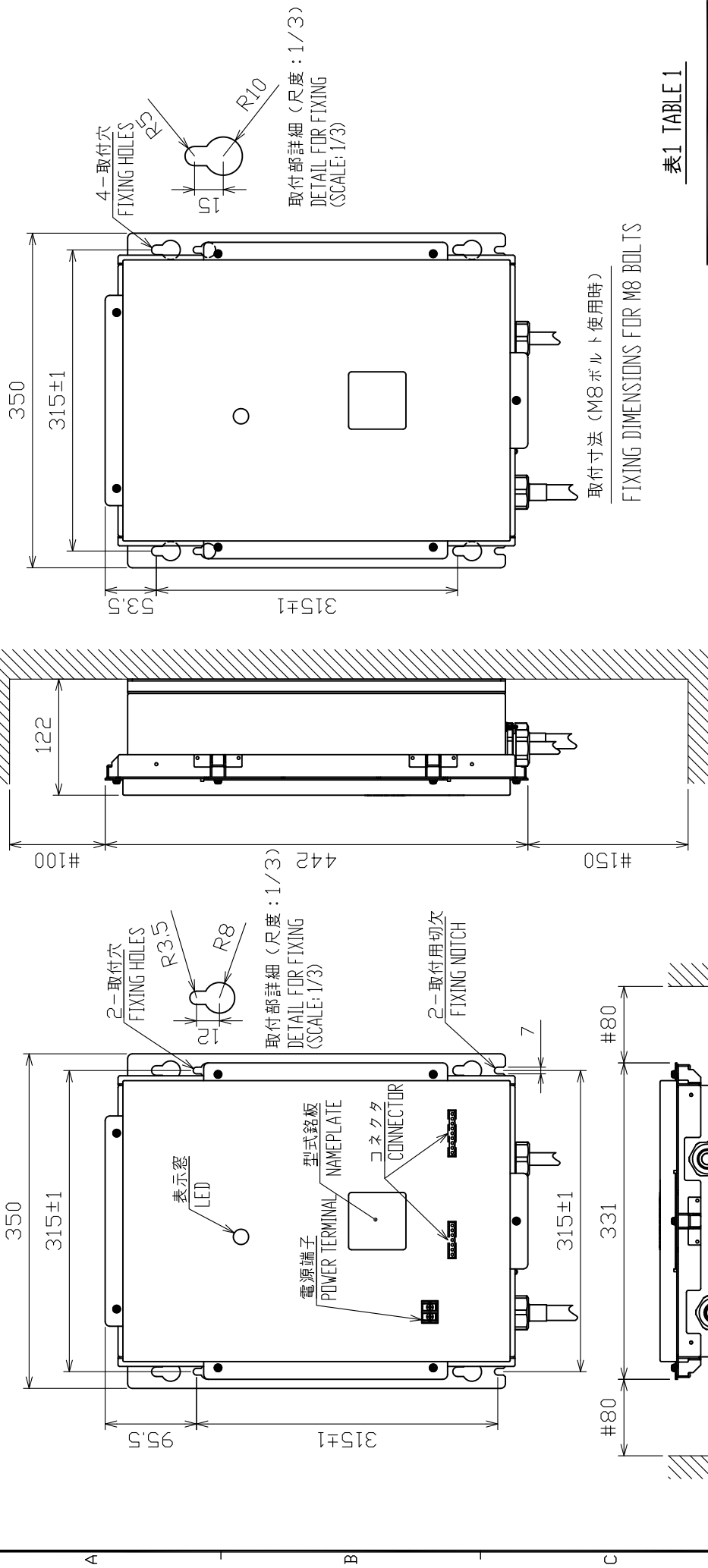
取付寸法 (M8 ボルト使用時)
FIXING DIMENSIONS FOR M8 BOLTS

注 記

- 1) 指定外の寸法公差は表 1 による。
- 2) #印寸法は最小サービスクリアランスとする。
- 3) 取付用ネジはトラスターピンネジ呼び径 6 × 30 または M6 / M8 ボルトを使用のこと。

DRAWN 6/Apr/2020 I.YAMASAKI	TITLE DS-8520
CHECKED 6/Apr/2020 H.MAKI	名称 送受信機(壁掛装置)
APPROVED 6/Apr/2020 H.MAKI	外寸図
SCALE 1/6 MASS 6 印字 6g	NAME TRANSCEIVER UNIT (BULKHEAD MOUNT)
DWG.No. C7288-601-B REF.No. 65-008-130G-4	OUTLINE DRAWING

表1 TABLE 1

寸法区分 (mm) DIMENSION	公差 (mm) TOLERANCE
L ≤ 50	±1.5
50 < L ≤ 100	±2.5

表2 TABLE 2

装備ケーブル長 (m) CABLE LENGTH	質量 (kg±10%) MASS
10 ^{+1.0m} / _{-0.5m}	2.2
20 ^{+1.0m} / _{-0.5m}	4.0
30 ^{+1.0m} / _{-0.5m}	5.8
40 ^{+1.0m} / _{-0.5m}	7.6

A

B

C

D

ジュビリクリップ
HOSE CLAMP

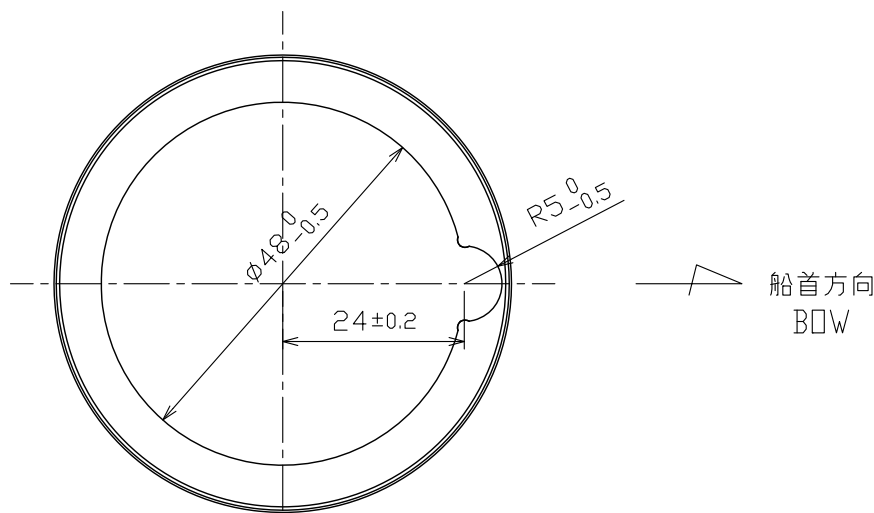
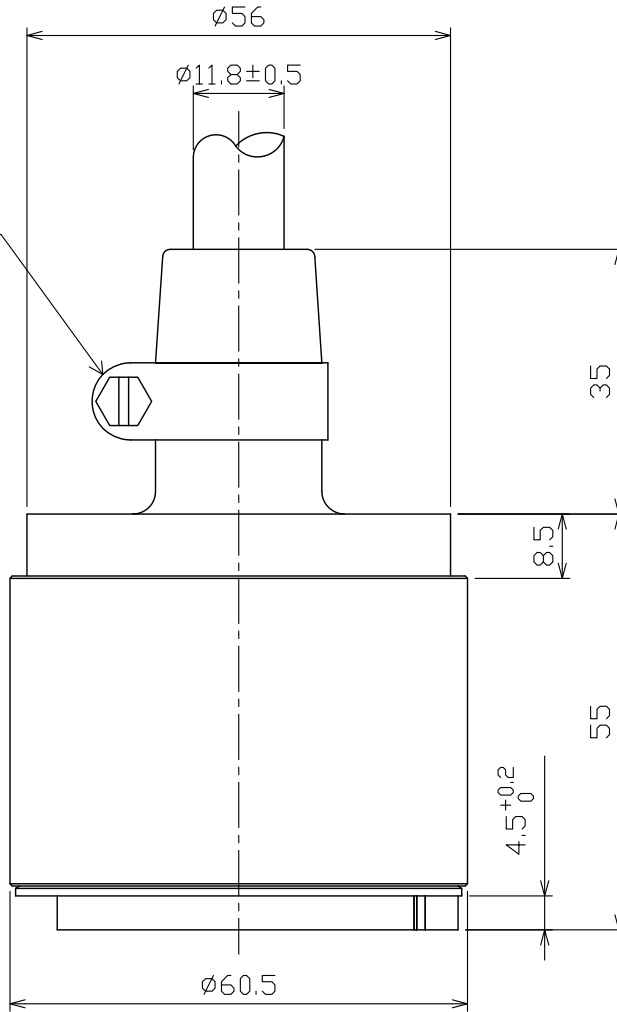

注記

1) 指定なき寸法公差は表1による。

NOTE

1. TABLE 1 INDICATES TOLERANCE OF DIMENSIONS WHICH IS NOT SPECIFIED.

DRAWN 31/Mar/2020 T.YAMASAKI		TITLE DS-8530
CHECKED 31/Mar/2020 H.MAKI		名称 送受波器
APPROVED 2/Apr/2020 H.MAKI	DS-85	外寸図
SCALE 1/1	MASS 表2参照 TABLE 2	NAME TRANSDUCER
DWG. No. C7288-G05- B	REF. No. 65-008-140G- 1	OUTLINE DRAWING

A

B

C

D

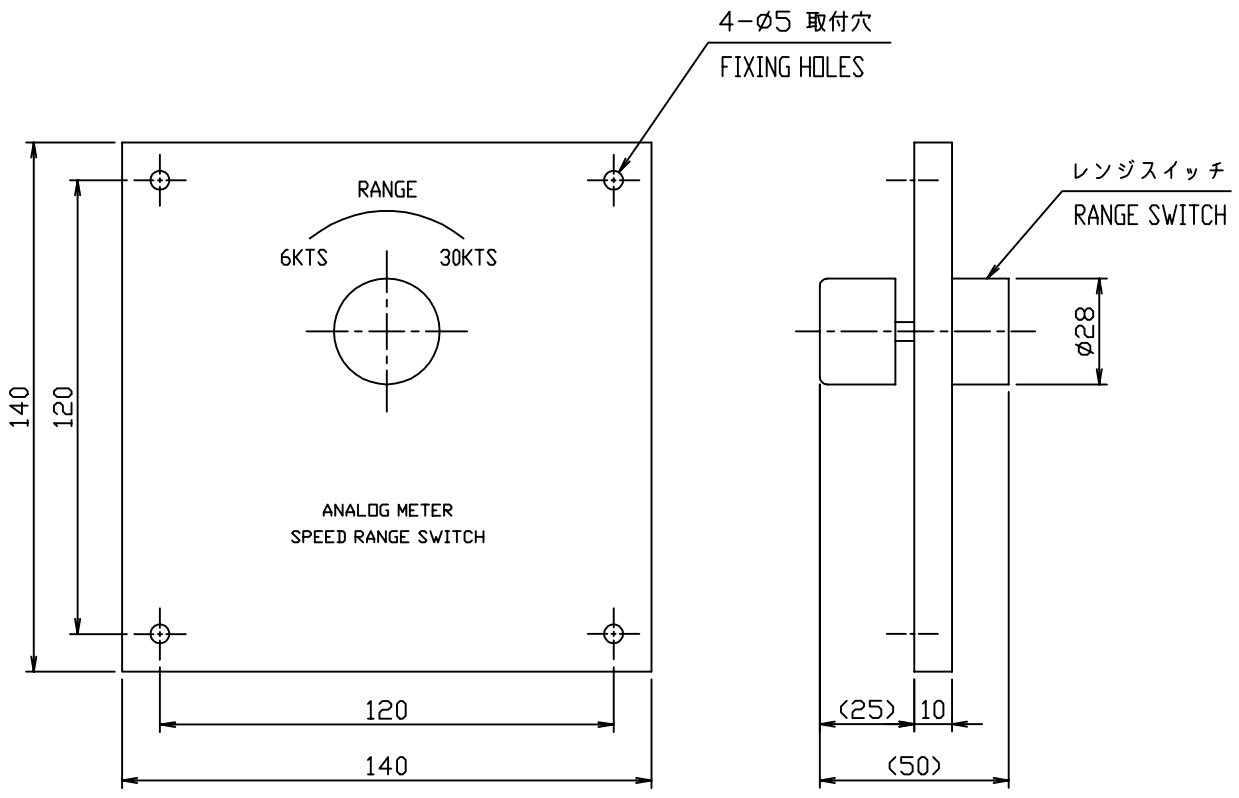

品番 ITEM	品名 NAME	材質 MATERIAL	数量 Q'TY	図番 DWGNO.	摘要 REMARKS
DRAWN Jun. 27 '01 T. YAMASAKI				TITLE MF-22R-1	
CHECKED Jun. 27 '01 Y. KIMURA				名称 アナログ指示器レンジ切換器	
APPROVED Jun. 27 '01 Y. KIMURA				外寸図	
SCALE 1/2 MASS 0.7 \pm 10% kg				NAME ANALOG DISPLAY RANGE SWITCH (FLUSH MOUNT)	
DWG.No. C7203-080-D				OUTLINE DRAWING	

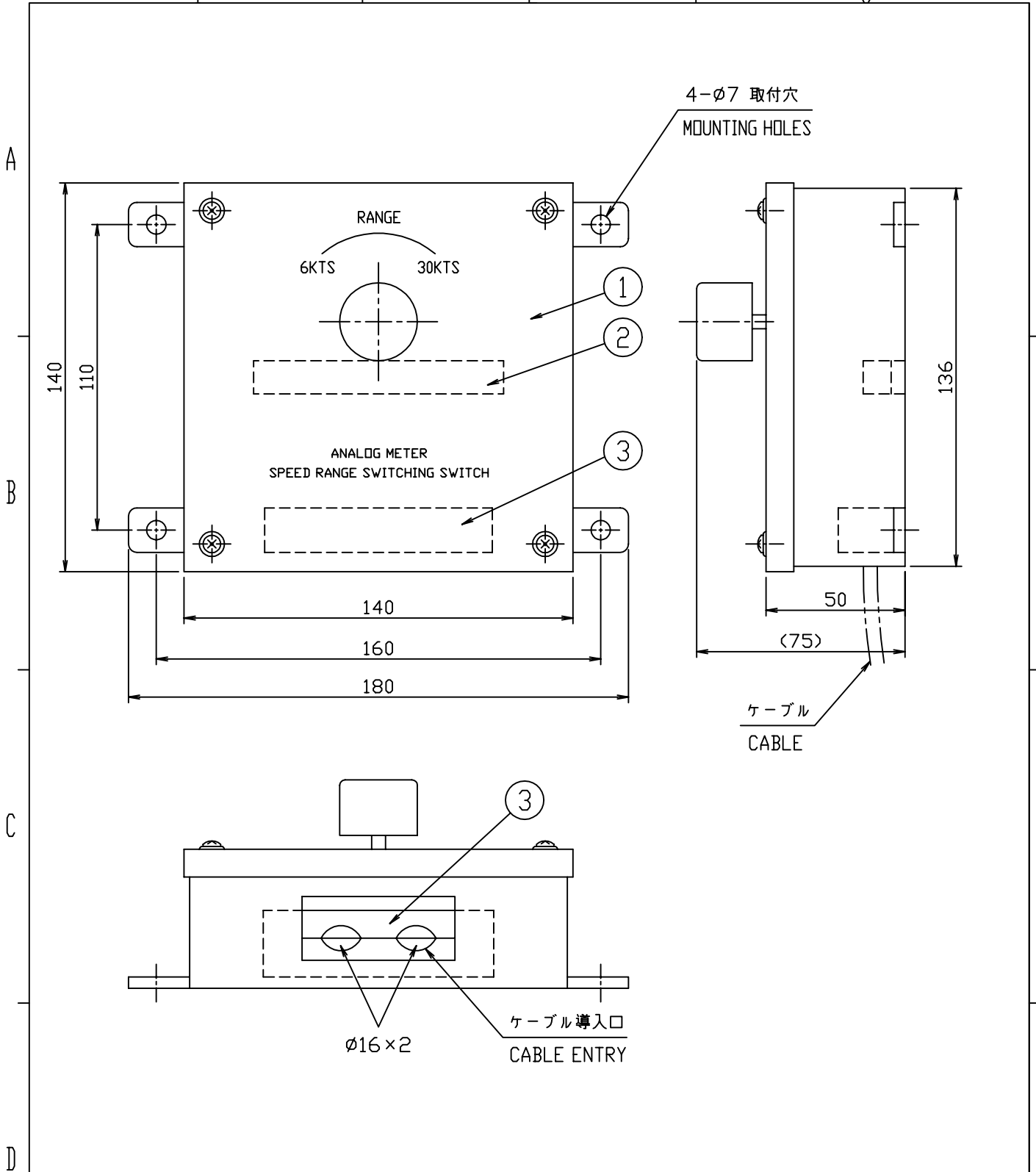

3	ケーブル クランプ CABLE CLAMP	A5052B	1		
2	端子台 TERMINAL STRIP		1		10P-3mm
1	ケース本体 HOUSING	SPCC	1		
品番 ITEM	品名 NAME	材質 MATERIAL	数量 Q'TY	図番 DWGNO.	摘要 REMARKS

DRAWN Jun. 27 '01	T. YAMASAKI	TITLE MF-22R-2
CHECKED Jun. 27 '01	Y. KIMURA	名称 アナログ指示器レンジ切換器
APPROVED Jun. 27 '01	Y. KIMURA	外寸図
SCALE 1/2	MASS 1.1 ±10% kg	NAME ANALOG DISPLAY RANGE SWITCH (BULKHEAD MOUNT)
DWG.No. C7203-063-F		OUTLINE DRAWING

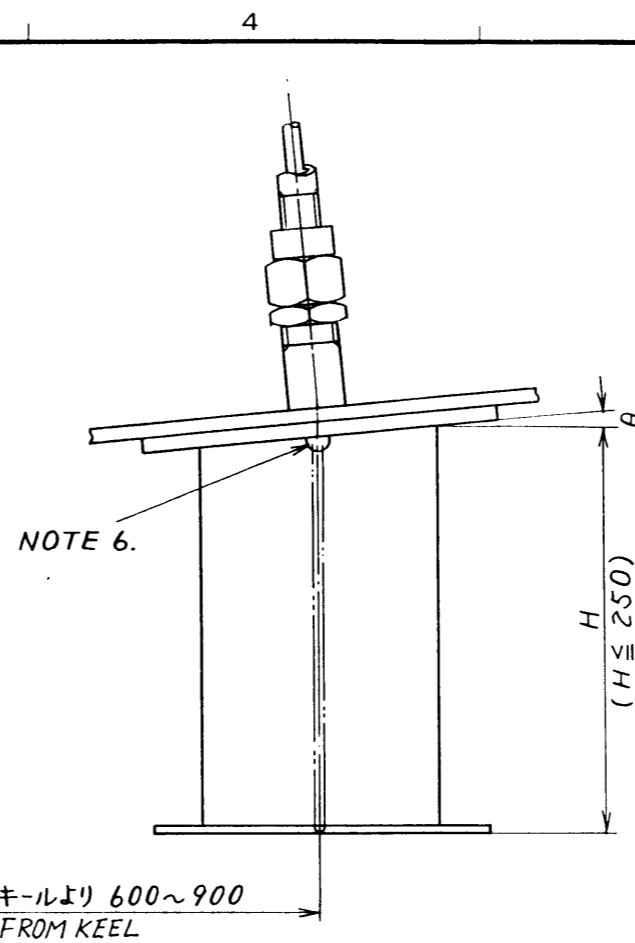
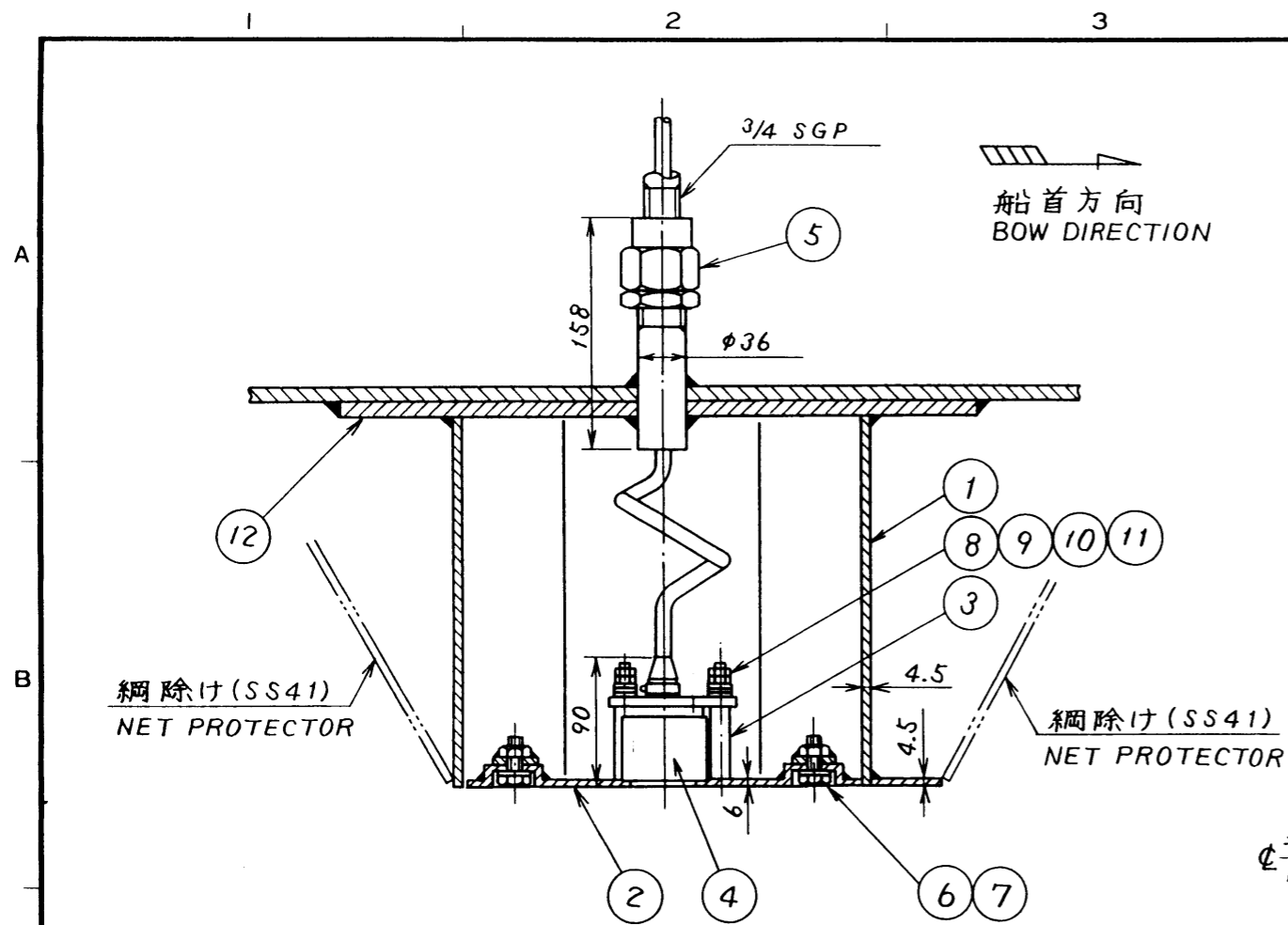

NOTE

- θは船底傾斜角。
 - 要目表は船主又は造船所と協議の上記入すること。
 - 網除け、保護タンクは必要に応じて造船所にて製作のこと。
 - 電線貫通金物はフレーム等のじゃまにならない所で振動子に当らず、キャップナットが容易に締付けられる位置に取付けること。
 - 船尾側上端に空気抜き用穴(φ10~φ20程度)を明けて下さい。
 - 振動子ケースを船底に溶接する際"FORE"マークを確認して船首-船尾方向の取付誤差は±1°以内とすること。
 - 振動子面と水平面との平行取付誤差は±1°以内になるよう振動子ケースを切断すること。
- θ: RISING ANGLE OF SHIP'S HULL.
 - DECIDE PRINCIPAL ITEMS UPON DISCUSSING WITH SHIP'S OWNER OR SHIPYARD.
 - IF NECESSARY, NET PROTECTOR AND PROTECTION TANK TO BE MADE BY SHIPYARD.
 - ALLOW ENOUGH CLEARANCE AROUND THRU-HULL PIPE FOR EASY TIGHTENING AND SERVICING.
 - MAKE A HOLE OF 10 TO 20 MM IN DIA. ON STERN SIDE TO ALLOW AIR TO ESCAPE FROM TANK.
 - WHEN WELDING THE TRANSDUCER HOUSING TO HULL, CONFIRM "FORE" MARK.
 - FORE-AFT INSTALLATION ERROR SHOULD BE WITHIN ±1 DEGREE.
 - CUT THE TRANSDUCER HOUSING SO THAT THE FACE OF TRANSDUCER IS ALIGNED IN PARALLEL WITH THE DRAFT LINE. (WITH IN ±1 DEGREE)

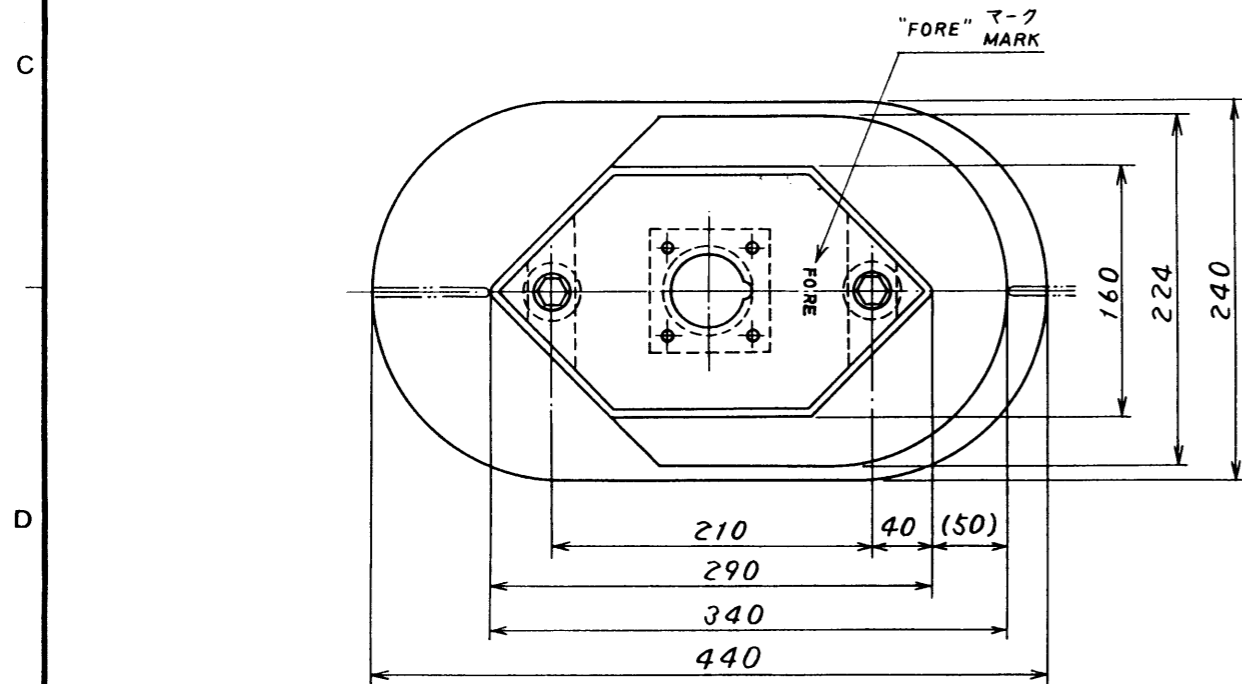

要目表 PRINCIPAL ITEM		
位置 POSITION	船首から FROM BOW	m
	キールから FROM KEEL	mm
突出量 PROJECTING	H	mm
取付状態 FIXING CONDITION	走行時水平 HORIZONTAL AT RUNNING	
保護タンク PROTECTION TANK		

12	補強板 DOUBLING PLATE	SM41	1		造船所手配 DOCKYARD SUPPLY
11	六角ナット (M8) HEX. NUT	SUS304	8		
10	バネ座金 SPRING WASHER (M8)	SUS304	4		
9	平座金 FLAT WASHER (M8)	SUS304	4		
8	平ワッシャ (呼び8) FLAT WASHER (NOMI. 8)	P.C.	4		
7	バネ座金 SPRING WASHER (M10)	SUS304	2		
6	六角ボルト (M10×30) HEX. BOLT	SUS304	2		
5	5号電線貫通金物 THRU HULL PIPE NO.5		1	TFB-5000	
4	送受波器 TRANSDUCER			DS-785/820	
3	スペーサ SPACER	SGP40A	4	T-606-03	
2	振動子取付フランジ TRANSDUCER FIXING FLANGE	SS41	1	65-003-9201	
1	振動子ケース TRANSDUCER HOUSING	SS41	1	T-604-01	
品番 ITEM	品名 NAME	材質 MATERIAL	数量 Q'TY	図番 DWG.NO.	摘要 REMARKS

DRAWN Oct 13 '00 T. YAMASAKI		TYPE DS-781
CHECKED Oct 13 '00 Y. K...		名称 船底タンク (突出型)
APPROVED Oct 13 '00 Y. K...	DS-80 DS-70	送受波器装備図
SCALE 1/5	MASS 11 kg	APPLICABLE TO; (MODEL)
DWG NO. C7222-T05-C	BLOCK NO.	NAME SEACHEST (PROJECTION TYPE)
		TRANSUCER INSTALLATION

A

B

C

D

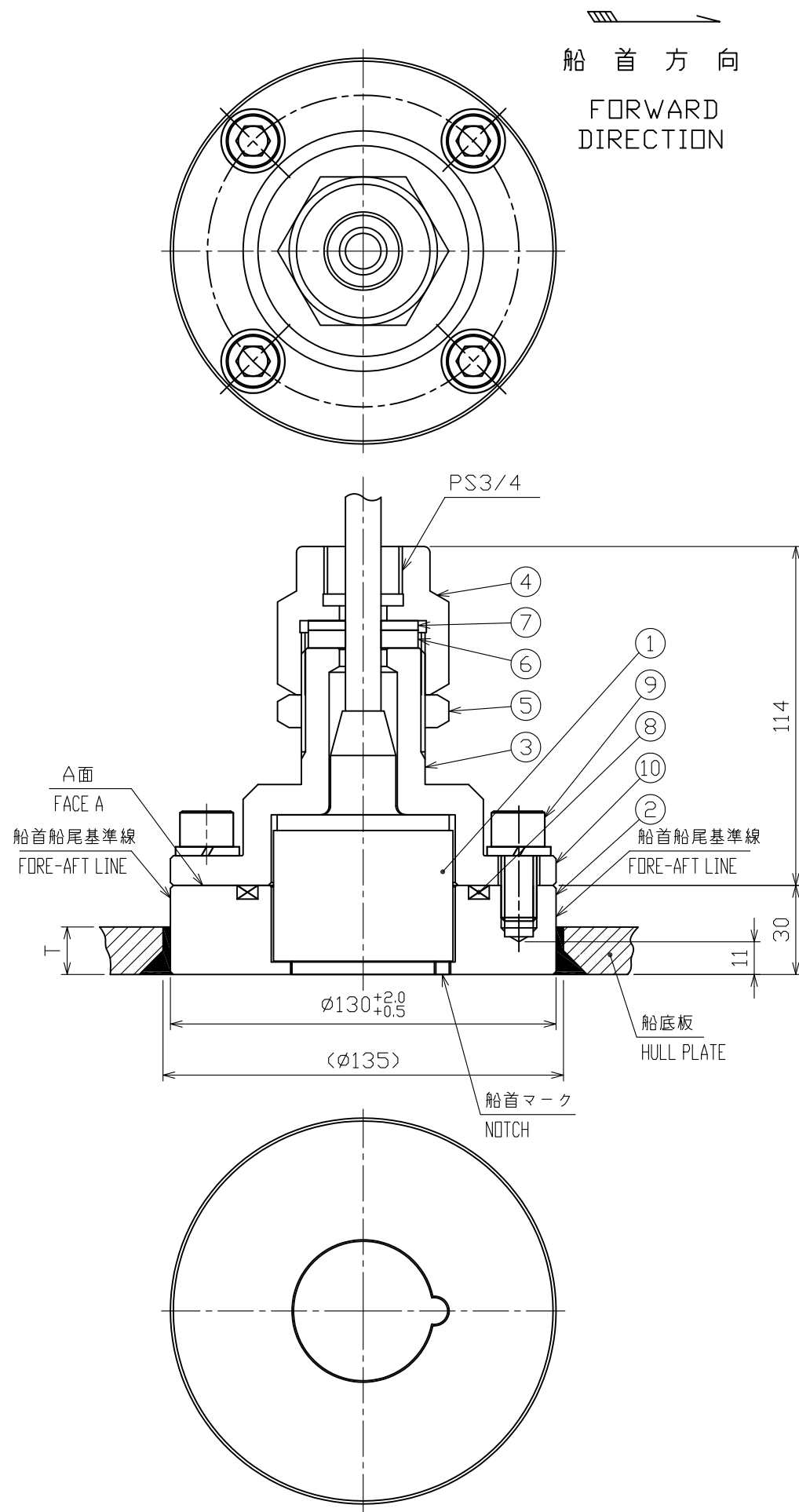

取付要領

- 1 ⑤止めナットを緩め(仮締めなので手で回る。堅い時は対辺50mmスパナを使用のこと)。
④キャップナットを②振動子フランジから外す(ケーブルから抜き取る必要はない)。
⑥ガスケット、⑦座金を④キャップナットの方へ移しておくこと。
- 2 ⑨M12六角穴付きボルト4本を外し(対辺10mm六角棒スパナを使用)、③振動子フランジと①振動子を②船底フランジから分離する。⑩ボルト、⑪ばね座金、⑫Oリングは保管しておく。
- 3 ②船底フランジを船底に溶接する。この時以下の点に注意のこと。
・側面に刻印されている“FORE”の文字と船首、船尾の2本の基準線を船の船首-船尾方向に合わせて溶接する。(取付誤差は±1°以内)
・水平方向も吃水線と平行になるように溶接する。(取付誤差は±1°以内)
- 4 船底溶接部はグラインダー等で面一に仕上げる。
- 5 付属のキノラスク(金属スキマ腐食防止剤)を②船底フランジのフランジ面(A面)、リング溝内及び振動子フランジ面(A面)に塗布する。
- 6 ⑫Oリングを②船底フランジに装着する。
- 7 ①振動子を②船底フランジにはめ込む。(船首マークである②船底フランジの切欠と①振動子の突起を合わせること。)
- 8 ③振動子フランジを②船底フランジに乗せる。
- 9 ⑨六角穴付きボルトを締付ける。(③振動子フランジは船首方向に関係なく任意方向でよい)
- 10 ⑥ガスケット、⑦座金を③振動子フランジ上に移し④キャップナットを締める(対辺50mmスパナ使用)。それから⑤止めナットを緩み止めとして④キャップナットにかける。
- 11 振動子ケーブルに配管する時は、④キャップナット上部のPS3/4ねじを利用すること。

Mounting Procedure

- 1 Loosen lock nut ⑤ with a wrench (hex. size: 50mm) and take off cap nut ④ from hull flange ③ together with gasket ⑥ and flat washer ⑦. (It is not necessary to draw the cap nut completely out from the cable.)
- 2 Unscrew hex. socket head bolts ⑨ (M12x25, 4 pcs.) by using a socket screw wrench (size: 10mm). Separate flange ③ and transducer ① from hull flange ②. Handle O-ring ⑫ carefully so as not to damage it.
- 3 Weld hull flange ② to the hull plate. Confirm that the "FORE" mark is orientated to fore and alignment lines on the side of hull flange are in parallel with the fore-aft line of the ship within ±1 degree. The hull flange ② should also be horizontal within ±1 degree at ship's normal trim.
- 4 Finish the outside of hull flange with a grinder to ensure smooth water-flow.
- 5 Apply Kinoruster (Anti-crevice corrosion sealant) to face A of hull flange ②, O-ring groove on the hull flange, O-ring ⑫ and face A of the flange.
- 6 Fit O-ring ⑫ onto the O-ring groove.
- 7 Place transducer ① into hull flange ② so that the alignment nipple on the transducer face fits into the notch on the hull flange.
- 8 Settle flange ③ on the hull flange ②.
- 9 Tighten hex. socket bolts ⑨ with a socket screw wrench.
- 10 Put gasket ⑥ and flat washer ⑦ on the top of the flange and tighten cap nut ④ securely with a wrench (hex. size: 50mm). Screw lock nut ⑤.
- 11 When running the transducer cable inside the conduit pipe, screw the pipe end onto the cap nut (PS3/4) for watertightness.

10	バネ座金 SPRING WASHER	SUS316L	4	M12	
9	六角穴付きボルト SOCKET HEAD SCREW	SUS316L	4	M12x25	
8	Oリング O-RING	NBR	1	JISB2401-1A-P75	
7	平座金 FLAT WASHER	SPC	1	65-003-9106	
6	ガスケット GASKET	CR	1	65-003-9105	
5	六角ナット HEX. NUT	SS400	1	65-003-9104	
4	キャップナット CAP NUT	SS400	1	65-003-9103	
3	振動子フランジ(L) FLANGE LB	SS400	1	65-003-9101	
2	船底フランジ HULL FLANGE LB	KAS	1	65-003-9102	船級認定材 CLASSIFICATION SOCIETY APPROVED MATERIAL
1	送受波器 TRANSDUCER			DS-785/820	
品番 ITEM	品名 NAME	材質 MATERIAL	数量 QTY	図番 DWG. No.	摘要 REMARKS

DRAWN	16/Nov/2016 T.YAMASAKI	TITLE	DS-784	
CHECKED	16/Nov/2016 H.MAKI	名称	船底タンク(埋込型)	
APPROVED	17/Nov/2016 H.MAKI	DS-70/80	送受波器装備図	
SCALE	1/2	質量は送受波器を含まず。 MASS DOES NOT INCLUDE TRANSDUCER.	NAME	SEACHEST (FLASH TYPE)
DWG. No.	C7222-T06-E	REF. No.	65-003-910G-2	TRANSDUCER INSTALLATION

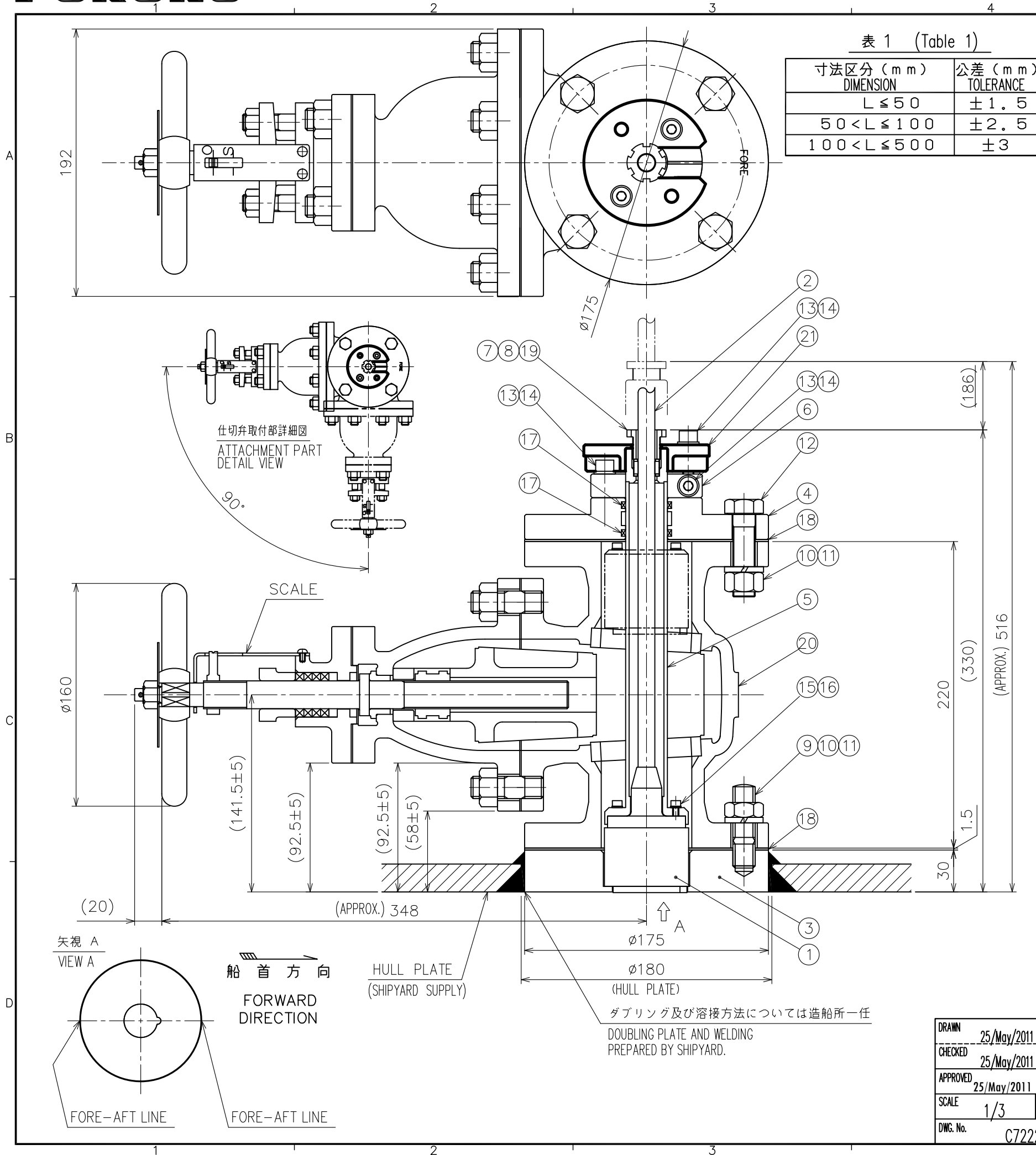

- 注記
- フランジ③を船底に溶接する際、船首-船尾方向、水平方向の各取付誤差は±1度以内として下さい。
 - 金属スキマ腐食防止剤(キノラスタ)を、フランジ③④のシール面、ガスケット⑬の両面、ゲートバルブ⑳のフランジ面に塗布して下さい。
 - ゲートバルブ⑳を取付ける際はナット⑩の回り止め対策として、ボルト⑨⑫およびナット⑩を脱脂後、ロックタイト#271を塗布して完全に締めて下さい。
 - フランジ④、シャフト⑤を組み込む際は、FOREマークを合せること。
 - ゲートバルブ⑳以外の部分は 4.9×10^5 Pa の水圧試験がされています。
 - ゲートバルブ⑳は、90°ピッチで任意の方向に取付け可能です。
 - 指定外の寸法公差は表1の通りです。

- NOTE
- WHEN WELDING HULL FLANGE ③ TO SHIP'S HULL PLATE, FORE-AFT AND HORIZONTAL ATTACHMENT ERROR SHOULD BE LESS THAN ±1 DEGREE.
 - APPLY ANTI-CREVICE CORROSIVE SEALANT (KINORUSTER) TO SEAL FACE OF FLANGE ③④ AND TO BOTH FACES OF GASKET ⑬ AND FLANGE OF GATE VALVE ⑳.
 - PRIOR TO SECURE NUTS ⑩, CLEAN BOLTS ⑨⑫ AND NUTS ⑩ WITH SOLVENT AND APPLY LOCTITE #271 TO THREADS OF THEM.
 - ALIGN "FORE" MARK WITH BOW, WHEN INSTALLING UPPER FLANGE④ AND SHAFT⑤.
 - PARTS EXCEPT GATE VALVE ⑳ IS TESTED UNDER 4.9×10^5 Pa PRESSURE.
 - GATE VALVE ⑳ CAN BE ATTACHED IN ANY DIRECTION IN 90° PITCH.
 - TABLE 1 INDICATES TOLERANCE OF DIMENSIONS WHICH IS NOT SPECIFIED.

品番 ITEM	品名 NAME	材質 MATERIAL	数量 QTY	図番 DWG. No.	摘要 REMARKS
21	押え板 FIXING PLATE	S45C	1	65-003-9307	
20	ゲートバルブ GATE VALVE ZINC RICH PRIMER	SC480	1	65-003-9311 (JIS F 7366-65S)	船級認定品 CLASSIFICATION SOCIETY APPROVED
19	グラウンド FIXING GRAND	BRASS	1	JIS F8801㊦r15	
18	ガスケット GASKET	JOINT SHEET	2	JIS 10K65A1.5mm	
17	リング O-RING	NBR	2	JIS B2401-P30	
16	座金 WASHER	SUS/NBR	4	M4	
15	六角穴付きボルト HEX. S.H.C. SCREW	SUS316L	4	M4×16	
14	バネ座金 SPRING WASHER	SUS316L	5	M8	
13	六角穴付きボルト HEX. S.H.C. SCREW	SUS316L	5	M8×30	
12	ボルト BOLT	SUS316L	4	M16×60	
11	バネ座金 SPRING WASHER	SUS316L	8	M16	
10	ナット NUT	SUS316L	8	M16	
9	植込みボルト STUDS	SUS316L	4	M16×40	
8	座金 WASHER	SPC	2	65-003-9306	
7	ガスケット GASKET	CR	1	65-003-9305	
6	ロックリング ROCK RING	SS400	1	65-003-9304	
5	シャフト SHAFT	SUS316L	1	65-003-9303	
4	フランジ FLANGE	SUS316L	1	65-003-9302	
3	船底フランジ FLANGE RUST PREVENTIVE OIL	KA	1	65-003-9301	船級認定材 CLASSIFICATION SOCIETY APPROVED MATERIAL
2	ケーブル TRANSDUCER CABLE				φ11.8
1	送波器 TRANSDUCER		1		DS-785/820

DRAWN	25/May/2011 J.YAMASAKI	TITLE	DS-786	
CHECKED	25/May/2011 H.MAKI	名称	ゲートバルブ式送波器タンク	
APPROVED	25/May/2011 Y.NISHIYAMA	DS-70/80	送波器装備図	
SCALE	1/3 MASS 40.0 ±10% kg	質量は送波器を含まず。 MASS W/O TRANSDUCER.	NAME	TRANSDUCER TANK (SEACHEST TYPE W/ GATE VALVE)
DWG. No.	C7222-T04-H	REF. No.	65-003-930G-6	TRANSDUCER INSTALLATION



表1 (Table1)

寸法区分 (mm) Dimension	公差 (mm) Tolerance
L ≤ 50	±1.5
50 < L ≤ 100	±2.5
100 < L ≤ 500	±3
500 < L ≤ 1000	±4

- 注記 1. フランジ③を船底に溶接する際、船首-船尾方向、水平方向の各取付誤差は±1度以内としてください。
 2. 液状ガスケットTB1121を、フランジ③④のシール面、ガスケット⑱の両面、ボールバルブ⑳のフランジ面に塗布してください。
 3. フランジ④、シャフト⑤を組み込む際は、FOREマークを合せること。
 4. ボールバルブ⑳は、90°ピッチで任意の方向に取付可能です。
 5. 指定外の寸法公差は表1の通りです。

- NOTE 1. THE FLANGE③ SHOULD BE WELDED TO SHIP'S HULL PLATE, FORE-AFT AND HORIZONTAL ERROR WITHIN ±1 DEGREE.
 2. APPLY LIQUID GASKETS TB1121 TO THE FACES OF FLANGE③④, BOTH FACES OF GASKET⑱ AND THE FACES OF BALL VALVE⑳ FLANGE.
 3. ORIENT "FORE" MARKS OF FLANGE④ AND SHAFT⑤ TOWARD FORE DIRECTION.
 4. BALL VALVE⑳ CAN BE ATTACHED IN THE ARBITRARY DIRECTION IN 90° PITCH.
 5. TABLE 1 INDICATES TOLERANCE OF DIMENSIONS WHICH IS NOT SPECIFIED.

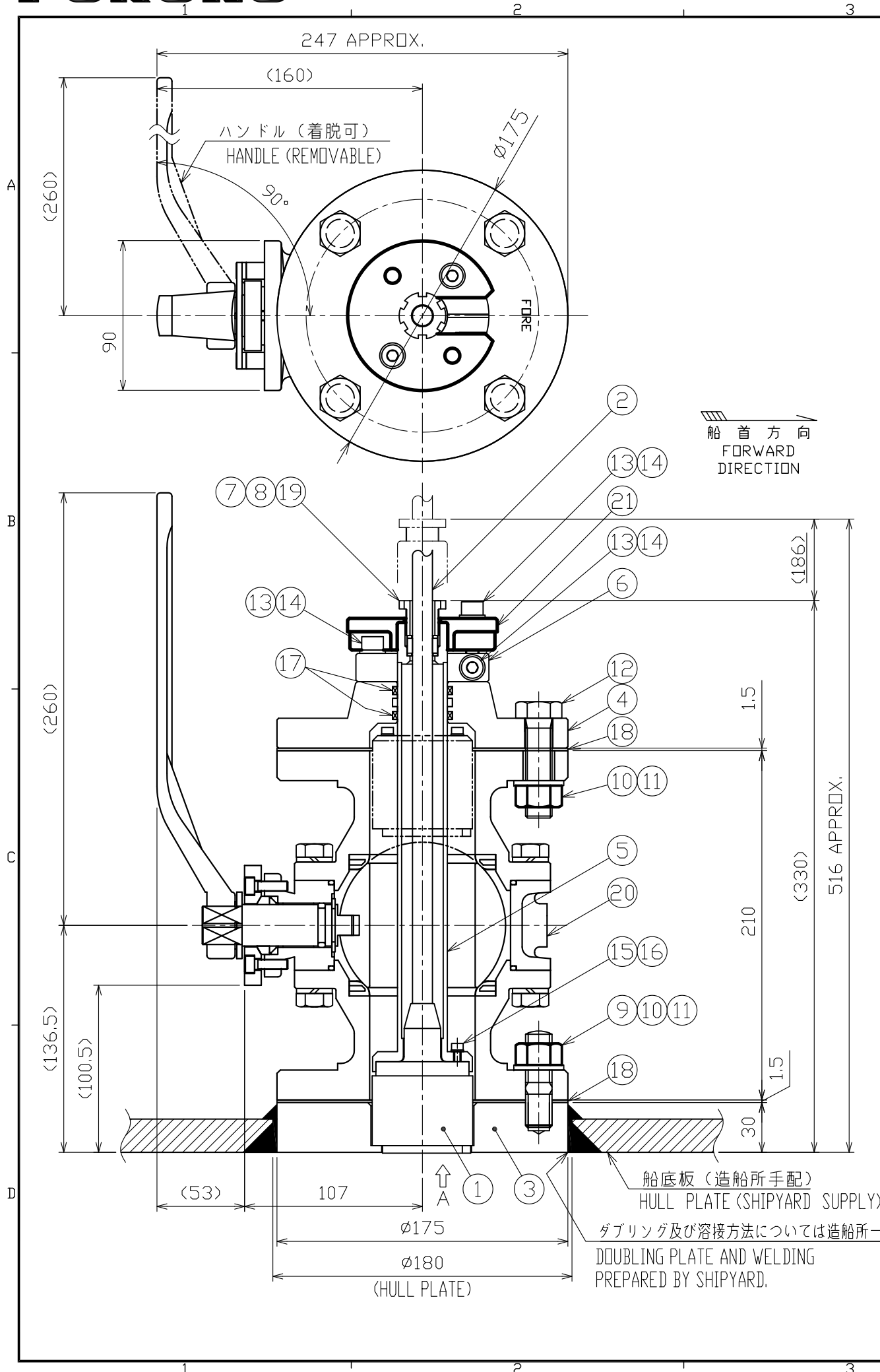
品番 ITEM	品名 NAME	材質 MATERIAL	数量 Q'TY	図番 DWG.NO.	摘要 REMARKS
21	押え板 FIXING PLATE	S45C	1	65-003-9307	
20	ボールバルブ BALL VALVE ZINC RICH PRIMER	FCD-S	1	65-003-9801 (JIS 10K 65)	船級認定品 CLASSIFICATION SOCIETY APPROVED
19	グラウンド FIXING GRAND		1	JIS F8801φ15	
18	ガスケット GASKET	JOINT SHEET	2	JIS 10K65A1.5mm	
17	Oリング O-RING	NBR	2	JIS B2401-P30	
16	座金 WASHER	SUS/NBR	4	M4	
15	六角穴付きボルト HEX. S.H.C. SCREW	SUS316L	4	M4×16	
14	バネ座金 SPRING WASHER	SUS316L	5	M8	
13	六角穴付きボルト HEX. S.H.C. SCREW	SUS316L	5	M8×30	
12	ボルト BOLT	SUS316L	4	M16×60	
11	平座金 WASHER	SUS316L	8	M16	
10	ナット NUT	SUS316L	8	M16	
9	植込みボルト STUD	SUS316L	4	M16×40	
8	座金 WASHER	SPC	2	65-003-9306	
7	ガスケット GASKET	CR	1	65-003-9305	
6	ロックリング ROCK RING	SS400	1	65-003-9304	
5	シャフト SHAFT	SUS316L	1	65-003-9303	
4	フランジ FLANGE	SUS316L	1	65-003-9802	
3	船底フランジ FLANGE RUST PREVENTIVE OIL	KA	1	65-003-9301	船級認定材 CLASSIFICATION SOCIETY APPROVED MATERIAL
2	ケーブル TRANSDUCER CABLE				φ11.8
1	送受波器 TRANSDUCER		1		DS-785/820

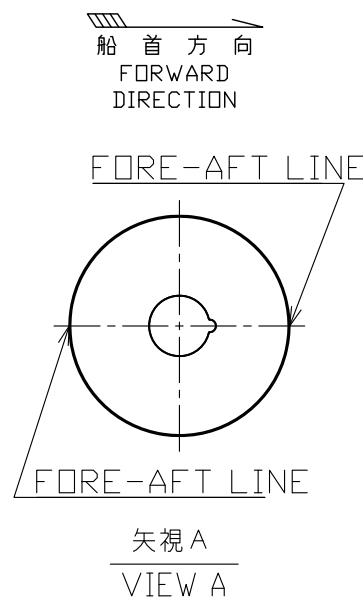

DRAWN	1/Apr/2020 T.YAMASAKI	TITLE	DS-854
CHECKED	1/Apr/2020 H.MAKI	名称	船底タンク (ボールバルブ式)
APPROVED	15/May/2020 H.MAKI	図番	DS-80/85
SCALE	1/3 MASS 27 ±10% kg	NAME	送受波器装備図
DWG. No.	C7288-T01-A	REF. No.	65-003-980G-0
		TRANSDUCER TANK (W/ BALL VALVE)	
		TRANSDUCER INSTALLATION	

